

# Eddystone

**MODEL  
EC958**

---

## **INSTALLATION NOTES OPERATING INSTRUCTIONS AND SERVICE DATA**

---

For Service Manuals Contact  
MAURITRON TECHNICAL SERVICES  
8 Cherry Tree Rd, Chinnor  
Oxon OX9 4QY  
Tel:- 01844-351694 Fax:- 01844-352554  
Email:- enquiries@mauriton.co.uk



## NOTE : : AC MAINS CONNECTOR

The following information is issued in compliance with British Standard BS415:-

If the colours of the wires in the mains lead of this apparatus do not correspond with the coloured markings identifying the terminals in your mains connector (or plug) proceed as follows:-

1. The GREEN/YELLOW wire must be connected to the plug terminal marked "E" or "  " or coloured GREEN or GREEN/YELLOW.
2. The BLUE wire must be connected to the plug terminal marked "N" or coloured either BLUE or BLACK.
3. The BROWN wire must be connected to the plug terminal marked "L" or coloured either BROWN or RED.
4. If a 13 amp (BS1363) FUSED PLUG is used to facilitate connection to the supply outlet, the plug MUST be protected by a 3 AMP FUSE unless expressly declared otherwise (see para. 5 below). If another type of plug is used, a fuse of the appropriate rating must be fitted either in the plug, or the adaptor, OR AT THE DISTRIBUTION BOARD.
5. NOTE :

A 3 AMP fuse rating is sufficient for most equipments, but in some instances, to allow for switching surges, it may be necessary to use a 5 AMP FUSE RATING. In all instances where the higher rating is applicable, specific notice will be given in the INSTALLATION SECTION of the handbook at the POWER SUPPLIES subsection.

# Eddystone

SOLID-STATE HIGH-STABILITY  
GENERAL COVERAGE RECEIVER

MODEL EC958

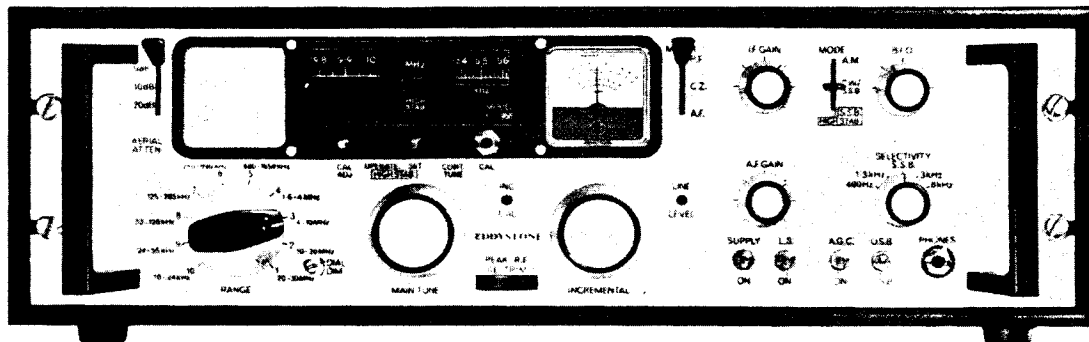

10 kHz - 30 MHz

**MODEL EC958/1:** WHEN THIS HANDBOOK IS SUPPLIED WITH AN EC958/1 RECEIVER, A SUPPLEMENT DETAILING CIRCUIT CHANGES ETC. IS BOUND IN ADVANCE OF THE FIRST SECTION DIVIDER CARD.

For Service Manuals Contact  
**MAURITRON TECHNICAL SERVICES**  
8 Cherry Tree Rd, Chinnor  
Oxon OX9 4QY  
Tel: 01844-351694 Fax: 01844-352554  
Email: enquiries@mauritron.co.uk

## LIST OF CONTENTS

	Page
<u>GENERAL DESCRIPTION</u> .. .. .	5
 <u>TECHNICAL DATA</u>	
GENERAL .. .. .	6
TYPICAL PERFORMANCE .. .. .	7
 <u>CIRCUIT DESCRIPTION</u>	
GENERAL .. .. .	9
THE RF SECTION .. .. .	10
THE TUNABLE IF .. .. .	12
HIGH-STABILITY OPERATION ON RANGES 1-4 .. .. .	14
THE 250kHz IF .. .. .	17
THE 100kHz IF .. .. .	18
THE AUDIO SECTION .. .. .	20
FREQUENCY SHIFT KEYING STAGES .. .. .	21
THE METER CIRCUITS .. .. .	21
POWER SUPPLY SECTION .. .. .	22
 <u>MECHANICAL CONSTRUCTION</u>	
GENERAL .. .. .	23
TUNING DRIVES AND SCALE DISPLAY .. .. .	29
 <u>INSTALLATION</u>	
GENERAL .. .. .	31
ASSEMBLY INSTRUCTIONS .. .. .	32
MAINS VOLTAGE ADJUSTMENT .. .. .	32
EXTERNAL CONNECTIONS .. .. .	33
DIVERSITY OPERATION .. .. .	36
SYNTHESISED OPERATION ON RANGES 5-10 .. .. .	37
 NOTE: Pages 39 & 40 do not appear in this handbook.	
 <u>OPERATION</u>	
CONTROL FUNCTIONS .. .. .	41
TUNING INSTRUCTIONS .. .. .	46
METER ADJUSTMENT .. .. .	49
 <u>MAINTENANCE</u>	
GENERAL .. .. .	51
FUSE AND LAMP REPLACEMENT .. .. .	51
FAULT DIAGNOSIS .. .. .	52
PERFORMANCE TESTING .. .. .	57
RE-ALIGNMENT .. .. .	60
REMOVAL AND INSTALLATION OF MODULES, UNITS ETC. .. .. .	64

## LIST OF CONTENTS

Page

### APPENDICES

"A"	OPERATING THE EC958 RECEIVER FROM LOW-VOLTAGE DC SUPPLIES .. .. .	I
"B"	VOLTAGE ANALYSIS .. .. .	II
"C"	SEMICONDUCTOR COMPLEMENT .. .. .	X
"D"	LIST OF COMPONENT VALUES, TOLERANCES AND RATINGS :: PART 1 : MAIN RECEIVER .. .. . PART 2 : TURRET DISKS .. .. .	XII XXIV
"E"	SPARES LIST FOR EC958 RECEIVER .. .. .	XXVIII
"F"	PRINTED CIRCUIT BOARD PATTERNS AND LEGENDS .. .. .	XXXV

### ILLUSTRATIONS (In Text)

	Frontispiece MODEL EC958 RECEIVER .. .. .	1
Fig. 1.	DIMENSIONS OF EC958 IN ALL MOUNTING STYLES .. .. .	23
Fig. 2.	PLAN VIEW OF EC958 RECEIVER .. .. .	25
Fig. 3.	UNDERSIDE VIEW OF EC958 RECEIVER .. .. .	26
Fig. 4.	MODEL EC958 :: ANCILLARY CONNECTIONS (PL & SK/C) .. .. .	35
Fig. 5.	COMBINED 600-OHM OUTPUT WIRING .. .. .	37
Fig. 6.	REAR VIEW OF EC958 RECEIVER SHOWING EXTERNAL CONNECTIONS .. .. .	38
Fig. 7.	FRONTAL VIEW OF EC958 RECEIVER SHOWING CONTROLS.. .. .	42

### ILLUSTRATIONS (Bound at rear)

BLOCK DIAGRAM OF MODEL EC958 RECEIVER

TURRET DISK CIRCUITRY :: PART 1 : TURRET DISKS 'A', 'B' & 'C'  
PART 2 : TURRET DISKS 'D', 'E' & 'F'

INTERCONNECTION CIRCUIT - MODEL EC958

MAIN CIRCUIT DIAGRAM - MODEL EC958

THE STANDARD EC958 RECEIVER HAS BEEN ALLOCATED  
THE FOLLOWING CIVIL AVIATION REFERENCE NUMBER:

10D/CA.10697

For Service Manuals Contact  
MAURITRON TECHNICAL SERVICES  
8 Cherry Tree Rd, Chinnor  
Oxon OX9 4QY  
Tel:- 01844-351694 Fax:- 01844-352554  
Email:- enquires@mauritron.co.uk

AMENDMENT RECORD

Amend No.	Content	Amended by	Date
1	Included in text	Eddystone	Jan '71
2	Included in text	Eddystone	Jan '71
3	Included in text	Eddystone	Jan '71
4	Included in text	Eddystone	Aug'72
5	Included in text	Eddystone	Aug'72
6	Included in text	Eddystone	Aug'72
7	Included in text	Eddystone	Aug'72
8*	Included in text	Eddystone	Aug'72
9			
10			
11			
12			
13			
14			
15			
16			
17			
18			
19			
20			
21			
22			
23			
24			
25			
26			
27			
28			
29			
30			

For Service Manuals Contact  
**MAURITRON TECHNICAL SERVICES**  
 8 Cherry Tree Rd, Chinnor  
 Oxon OX9 4QY  
 Tel: 01844 351694 Fax: 01844 352554  
 Email: enquiries@mauritron.co.uk

(\* ) Not issued separately.

Eddystone Radio Ltd. reserve the right to modify the content of this publication.  
 Amendment Sheets will be incorporated where necessary at date of issue.

AMENDMENT SHEET NO. 9

Interconnection  
Circuit

1. Transpose male/female contacts of coax interconnector Ref. 'U'.
2. Add R333 (1.2 $\Omega$ ) in earth return of RV15 (Dial Dimmer).
3. Change R20 to read:- 6.8K
4. Change R119 to read:- 680 $\Omega$
5. Change C309 to read:- 1 $\mu$ F
6. Change C376 & C377 to read:- 0.047 $\mu$ F
7. Change D31 to read:- 1N4004
8. Add C138 (0.1 $\mu$ F) from Pin 78 of Master Osc. Unit to earth.
- \*9. Add FSK Filter R329/C368/C369 at PL/C (refer Main Circuit).

(\* ) Not applicable to Model EC958/1.

Disk Circuits

- |               |          |          |    |                            |
|---------------|----------|----------|----|----------------------------|
| <u>Part 1</u> | Disk 'C' | Range 8  | :: | Delete R378                |
| <u>Part 2</u> | Disk 'D' | Range 10 | :: | Change C475 to read:- 50pF |
|               | Disk 'F' | Range 1  | :: | Change C491 to read:- 50pF |

For Service Manuals Contact  
MAURITRON TECHNICAL SERVICES  
8 Cherry Tree Rd, Chinnor  
Oxon OX9 4QY  
Tel:- 01844-351694 Fax:- 01844-352554  
Email:- enquiries@mauritron.co.uk

## Amendment No. 10

Page 3. Add to List of Accessories & Spares: 1 Allen Key 3/32" A.F. Part No. 9531P.

Page 59. Delete the section for the 935kHz Loop Module and replace by the following:-

Normal operation of the Loop Amplifier (IC3) can be verified by introducing an external unmodulated 935kHz signal at gate 1 of the 1st. Loop Mixer (via C67 with the lead to the disk contact disconnected). The HIGH-STAB indicator should light when the input level exceeds 0.7mV. An alternative check in the event of a fault existing in the legend lamp circuit is to feed a 1mV, 935kHz signal via C67 whilst monitoring the signal on coaxial lead "M". An output of 150-300mV should be obtained.

AFC operation should be checked by offsetting the signal introduced via C67 and reading voltage at Module Pin 34 with an electronic voltmeter. Readings should be of the order:-

935kHz - 3kHz : + 6.5V

935kHz : + 7.5V

935kHz + 3kHz : + 8.5V

Page X Change the type no. of TR4 to BFR29.  
Change the type no. of TR13 to BC107B.

Page XI Add DI3A : IN4004.  
Add DI4A : BZY88C10.  
Change the type no. of D3I to IN4004.  
Add for IC2 the alternative type no. SA20. Note that if type SA20 is fitted, C56 will change in value to 2.2pF.

Page XII Add C29, 10pF, Tubular Ceramic,  $\pm 10\%$ , 750V.

Page XIII Note the change to C56 if IC2 is type SA20, as above.

Page XV Change the value of C139 to 0.22 $\mu$ F.  
Add C150, 220 $\mu$ F, Tubular Electrolytic, + 80% - 20%, 16V.  
Change the value of C155 to 68pF Adjust on test.  
Change the value of C175 to 15pF Adjust on test.

Page XVI Change the value of C221 to 68pF  
Change the value of C229 to 68pF  
Change the value of C236 to 68pF.

- Page XVII Add C225A, 22 $\mu$ F, Tantalum Electrolytic, + 50% - 10%, 16V.
- Page XVIII Change the value of C333 to 0.001 $\mu$ F (Model 958/1 only)
- Page XIX Change the value of C350 to 100 $\mu$ F.  
Change the value of C370 and C371 to 7500 + 7500 $\mu$ F Dual Electrolytic.  
Change the value of C372 to 6800 $\mu$ F.
- Page XX Add R84A 33 $\Omega$ , 5%, 0.3W.  
Add R96, 560 $\Omega$ , 5%, 0.3W.  
Add R97, 100k $\Omega$ , 5%, 0.3W Adjust on test.
- Page XXII Change the value of R299 to 33 $\Omega$ .
- Page XXIII Change the value of R306 to 8.2k $\Omega$ .  
Change the value of R311 to 680 $\Omega$ .  
Change the value of RVI to 22k $\Omega$ .
- Page XXVI Change the value of C476 to 25pF.
- Page XXVIII Change the Part No. of the 935kHz Loop Amplifier Module to LP3055/1.  
Change the 250kHz IF Filter to Cat. No. SI504.  
Change the 1MHz Master Oscillator crystal to Type QC1545, part no. 9367P.
- Page XXIX Change RVI to 22k $\Omega$ , part no. 9587P.
- Page XXX Change the Part Nos. of the knobs as follows:-  
D3614 to LP3460/1  
D3613/3 to LP3459/1  
D3957 to LP3464/1  
D3958 to D4933  
and add Peak RF knob, Elma 71-14- $\frac{1}{4}$  with cap 1450-14. Skirt 7089/IP is no longer required as a separate item.
- Page XXXIII Note that on later models Power Transformer T5 is Part No. 9319P.
- Page XXXIV Change the Part No. of the Main Display Calibration Disc to 8475/IP  
(EC958).  
Change the Part No. of the Main Display Calibration Disc to 8475P (EC958/1)
- Page XXXVI Add D13A and R96 both in parallel with the coil of RLB. The anode of the diode to TR11 collector. Add R84A and D14A as explained below.

## Turret Disc Circuitry, Part 2.

Change the value of C476 to 25pF.

## Interconnection Circuit Diagram.

Change the value of R299 to 33 $\Omega$ .  
Change S3 and associated components as shown below.

## Main Circuit Diagram.

- , Delete D1-D4 and replace by PCI diode package. This is a similar configuration to D1-D4 but has 4 diodes in each chain.
- Change S3 and associated components as shown below.
- Add C29 (10p) in parallel with R40.
- Change the type no. of TR4 to BFR29.
- Note IC2 may be type SA20 and if so, C56 is 2.2pF.
- Change the reference of the 15pF capacitor marked C83 to read C88.
- Add R97 (100k Adjust on test) in parallel with C101.
- Add R96 (560) and D13A (1N4004) both in parallel with the coil of RLB. The anode of the diode is connected to the transistor collector.
- Add R84A (33) in series between R84 and pin 33, and D14A Zener diode from R84/R84A junction to common, cathode to common.
- Change the nominal value of C155 to 68p
- Change the value of C158 to .1
- Add C150, 220 $\mu$  electrolytic between pin 23 and common rail, positive to pin 23.
- Change the nominal value of C175 to 15p.
- Change the type no. of the 1MHz crystal to QC1545.
- Add the value .1 to C128.
- D18 should read type BZY88C6V2.
- Change the type no. of the 250kHz filter to S1504.
- Add C225A, 22 $\mu$ F electrolytic in parallel with C225, negative connected to common rail.
- Change the values of C221, C229 and C236 to 68p.
- Change the value of R299 to 33.
- Change the value of R306 to 8k2.
- Change the value of R311 to 680.
- Change the value of C350 to 100 $\mu$ .
- Change C370 and C371 to 7500 + 7500 $\mu$  dual electrolytic.
- Change the value of C372 to 6800 $\mu$ .

## Supplement I (Model 958/1 only)

- Page 3, 9. Change the value of R400 to 220 $\Omega$ .
- Page 3, 8. Change the value of C506 to 47 $\mu$ .

For Service Manuals Contact  
MAURITRON TECHNICAL SERVICES  
8 Cherry Tree Rd, Chinnor  
Oxon OX9 4QY  
Tel:- 01844-351694 Fax:- 01844-352554  
Email:- enquiries@mauritron.co.uk

For receivers Serial No. 2600 onwards also change:-

- Page 31 Table of Accessories supplied. Change part no. of Mains connector and lead to D4815 (was D2311/1).
- Page XXX Change the part nos. of Mains connector to D4815 (Plug and lead) and 8730P (Chassis mounted socket).

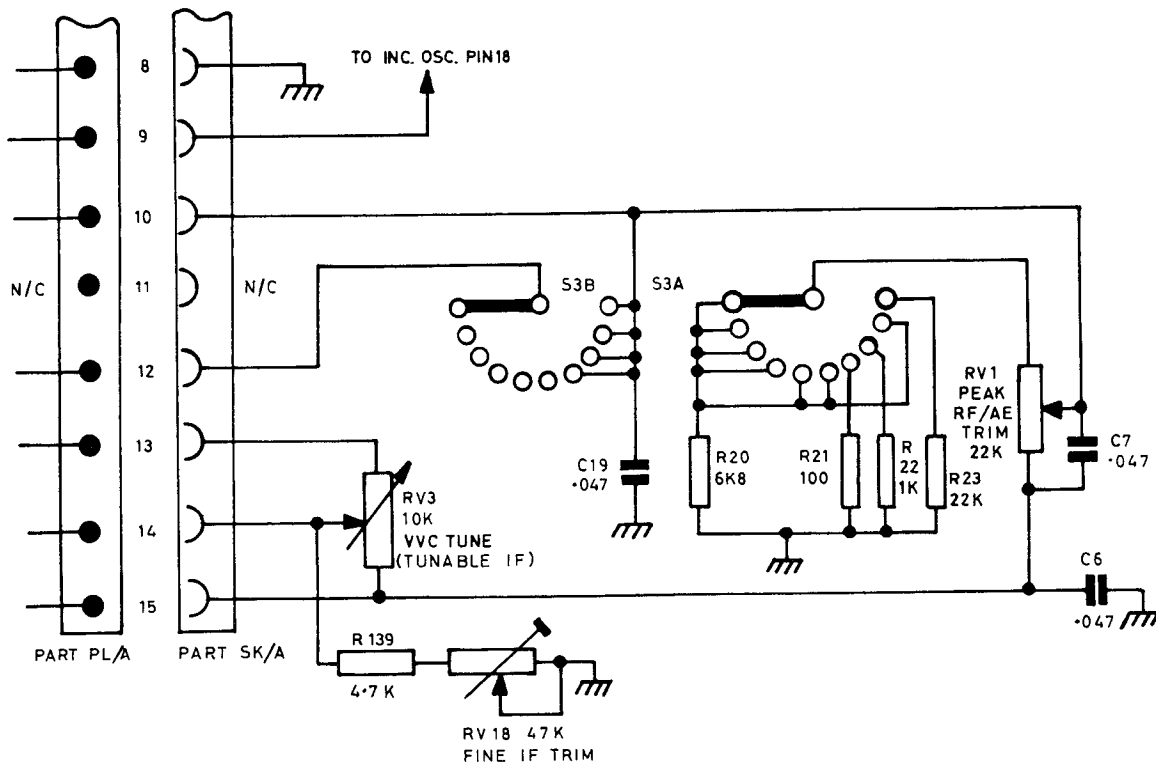

NOTE. NO CONNECTION TO PLA-11, SKA-11, PLB-6, PLB-7, SKB-6, SKB-7.

**INTERCONNECTION CIRCUIT MODIFICATION**

For Service Manuals Contact  
**MAURITRON TECHNICAL SERVICES**  
 8 Cherry Tree Rd, Chinnor  
 Oxon OX9 4QY  
 Tel:- 01844-351694 Fax:- 01844-352554  
 Email:- enquiries@mauritron.co.uk

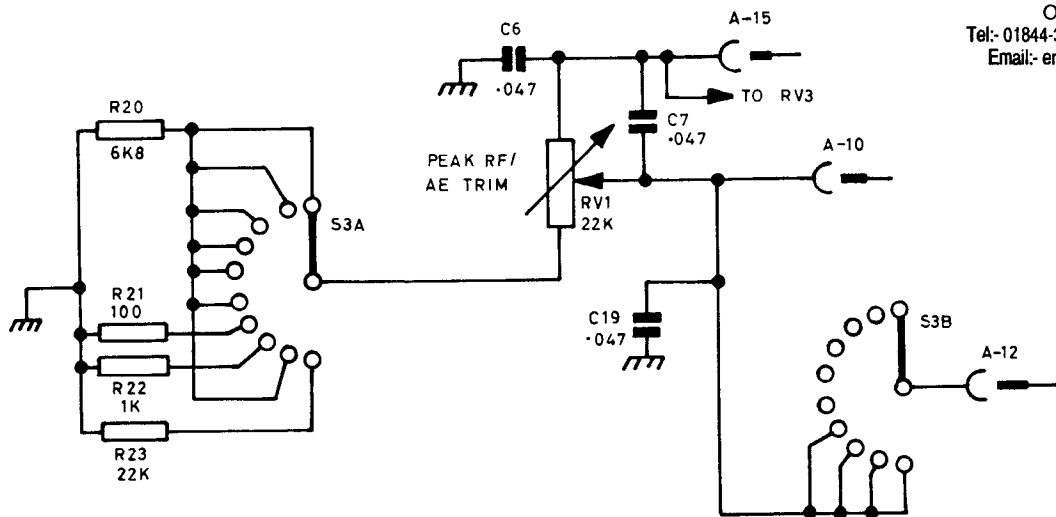

**CIRCUIT DIAGRAM MODIFICATION**

Eddystone Radio Ltd., Alvechurch Road, Birmingham B31 3PP, England. Tel: 021-475-2231.

November 1976.

## GENERAL AMENDMENT 958 SERIES (ALL MODELS)

The following modification has been introduced in order to reduce the possibility of failure of the 3rd. signal mixer stage formed by TR20 (250kHz IF Module).

ADD:-

1 off IN4004 diode to the a/m module circuitry connected from the drain of TR20 to ground. The diode is connected across pin Q/L and the ground pin. In all model variants the cathode of the diode is connected towards pin Q/L.

For 958/12 variant connect diode across pin CA/Q/L and ground; cathode towards pin CA/Q/L.

July 1978.

For Service Manuals Contact  
**MAURITRON TECHNICAL SERVICES**  
8 Cherry Tree Rd, Chinnor  
Oxon OX9 4QY  
Tel:- 01844-351694 Fax:- 01844-352554  
Email:- enquiries@mauritron.co.uk

FSK Module Cat. No. 1533

FSK Module Cat. No. 1533 is a direct mechanical replacement for the earlier module part number LP3058 described in the handbooks for the EC958 Series receivers. When the new module is fitted to a receiver all existing references in the handbook to the FSK Module should be deleted and the following description substituted. If Cat. No. 1533 is used as a replacement for LP3058 note that the value of R329 should be changed according to the table in the Realignment section.

Performance

With the module fitted to a correctly adjusted receiver, with  $1\mu\text{V}$  signal, 400Hz filter selected and AGC on, the minimum shift of 85Hz enables a transmission rate of 100 bauds to be resolved. Generally the relation: shift/baud rate  $\geq 0.5$  should be valid. The unit will respond to baud rates in excess of 300 (for shifts  $> 150\text{Hz}$ ). The maximum shift generally depends on the I.F. filter selected.

Installation

For Service Manuals Contact  
MAURITRON TECHNICAL SERVICES  
8 Cherry Tree Rd, Chinnor  
Oxon OX9 4QY  
Tel:- 01844-351694 Fax:- 01844-352554  
Email:- enquiries@mauritron.co.uk

1. Check the values of the resistors according to the table in the Realignment section.
2. Stand the receiver on its right-hand side.
3. Unplug the module leads from the dummy termination strip, noting the colour-code and sequence of the wires.
4. Remove the two 4BA retaining screws and the termination strip.
5. Place the module in position, replace the 4BA screws, shakeproof washers and earth tag (to pin 79).
6. Connect the leads to the module, in the sequence in which they were removed. Note that pin 82 is not used but is provided for safe stowage of the  $-6\text{V}$  supply lead.
7. Connect co-axial lead W to the spare socket on the 3-or 4-way junction box.

Circuit Description

The module is driven directly from the 100kHz I.F. Amplifier Module and provides solid-state switching for an external teleprinter supply. Bipolar supplies of  $\pm 6\text{V}$ ,  $\pm 80\text{V}$ , or unipolar supplies of 12V or 100V, can be switched.

Input and Pulse Shaping Circuits.

A signal at 100kHz, taken from the output of the 100kHz I.F. Amplifier Module is coupled via R651 and C651 and IC31. This first stage is a combined limiter and quadrature discriminator. The discriminator characteristic is determined by the phase shift network formed by L33 and the series/parallel combination of C655, C656 and C657. A further  $90^\circ$  phase shift to provide mid-range

discriminator output at the peak response of the tuned circuit is given by the phase-shift bridge network consisting of C656, C657, C658, R655. The output (at test point A) is a series of pulses which are coupled to IC32, a D.C. amplifier which provides a waveform of about 6V peak-to-peak amplitude. The D.C. level of this is adjusted under no-signal conditions to a nominal 5.5V by means of RV13. This stage limits when the RF input reaches about 400Hz peak-to-peak deviation. Pulses at the output of IC32 are shaped by the integration circuits R663/C666 and R665/C667 and fed to the tuning meter and a Schmitt trigger IC33. The trigger level is set by RV14 which is accessible through an aperture in the rear panel of the receiver, and is nominally 5.5V. The output from IC33 drives in antiphase the two LED's, which form part of the opto-isolators IC34 and IC35.

The power supply for the input and pulse shaping circuits is the receiver's 12V supply. Two independent 9V rails are derived from this by zener stabilisation. The discriminator and DC amplifier are fed from one rail and the Schmitt trigger and opto-isolators from the other, the total current drawn being about 40mA. Note that this part of the circuit is connected to the receiver circuit earth and is isolated from the output switching network.

#### Output Switching Network.

The drive to the switch is rectified so that voltage of the correct polarity is always applied to the switching transistors. In the description which follows the components used with Pin 86 positive and Pin 87 negative are shown without brackets whilst those used only when the polarities are reversed are bracketed.

When the L.E.D. in opto-isolator IC34 (IC35) is illuminated, the transistor will be turned "on" allowing a current to flow into the base of TR81. The supply for this is from the +80V rail via D89 (D90) and R673 (R674) and zener regulated and smoothed at 6.2V by D85 (D86) and C668 (C669). As the two L.E.D.'s are driven in anti-phase reversing the teleprinter supply will effect a mark-space reversal. With TR81 switched "on", TR82 will be "off" and TR83 "on". Current will flow through TR83 and D92 (D93) to the -80V supply and the output will therefore be held close to -80V and will sink current from the teleprinter.

When the L.E.D. in IC34 (IC35) is extinguished TR81 will be biased "off" by R671, and current will flow via R672 into the base of TR82, turning it "on". TR83 will be "off". In this case current will flow from the +80V supply via D91 (D94) and TR82 and so the output will be held close to +80V and will source current to the teleprinter. Diodes D87 and D88 protect the transistors from high voltages generated by the inductive load of the 'printer. The output current is limited by R329 (mounted in the receiver) and R672, R673, R674 and R329 should be adjusted in value to suit the current required and the supply voltage. The current drawn from the teleprinter supply is 25mA (at 80-0-80V) in addition to the current drawn by the teleprinter. This part of the circuit is isolated from the receiver circuit earth.

#### Maintenance

Switch the receiver into CW/SSB mode, connect an RF signal generator to the aerial input and tune generator and receiver to a convenient frequency. A CW beat note should be heard from the loudspeaker, provided this is switched on and the ancillaries plug inserted and wired correctly. If a beat note is not heard it is likely that a fault exists elsewhere in the receiver.

Connect a D.C. Voltmeter to Pin 84, connect + 80V printer supply (or use a bench supply) and check that a small change in frequency of the input signal, say + 200Hz causes the output to switch between the two states. Check +12V at Pin 83 and earth connections. Check the input lead.

#### Realignment.

Temporarily short-circuit the I.F. input at "W" and adjust RV13 to give + 5.5V ( $\pm 0.2V$ ) at test point C (Avo 8 - 25V DC).

Inject a 100kHz unmodulated signal of 50mV emf into co-axial lead 'W' (a suitable connector is included in the accessories kit), and adjust L33 to give +5.5V ( $\pm 0.5V$ ) at test point C. Note that slight adjustment of the core should swing the voltage at TP 'C' a few volts either way. Check that an input of 999.750kHz gives approx. + 8.8V and 100.250kHz gives approx. +2.3V at TP 'C'. Restore the input signal to 50mV emf at 100.000 kHz. Monitor the voltage (AV08 - 25V. DC) at test point D and adjust RV14 so that this voltage just switches (between 2.5V and 8.0V). The following conditions will then be found.

Using a low capacity probe (7pF in parallel with 10M $\Omega$ ) and oscilloscope or RF meter check the response at TP'B'. The bandwidths to 3dB points should be approx. 2.5kHz and the response at 100kHz should be within 1dB of the peak. Check the limiting action of IC31. Increasing the input level up to 200mV emf should cause only a small change in output, if any.

#### Output Switching Network.

The components fitted in this network suit a teleprinter supply of 80-0-80V to give an absolute maximum output current of 100-0-100mA bipolar, or 100V at 100mA unipolar. For different voltages and/or currents, the values should be altered according to the following table. In the case of intermediate values, the next highest resistance value should be used. It may be found that it is not necessary to lower the resistor values when a lower voltage is used. This is in order provided the 'printer operates satisfactorily. The reverse is NOT true and damage may result.

SUPPLY					
Bipolar	Unipolar	R672	R673	R674	R329
80-0-80V at 50-0-50mA	100V at 50mA	8.2k $\Omega$ 6 watt wirewound	33k $\Omega$ 1 watt wirewound	33k $\Omega$ 1 watt wirewound	1k $\Omega$ 12 watt wirewound
40-0-40V at 50-0-50 to 25-0-25mA	50V at 50 to 25mA	4.7k $\Omega$ 3 watt wirewound	15k $\Omega$ 1 watt metal film	15k $\Omega$ 1 watt metal film	390 $\Omega$ to 1k $\Omega$ 12 watt w.w.
20-0-20V at 50-0-50 to 25-0-25mA	25V at 50 to 25mA	2.2k $\Omega$ 3 watt wirewound	4.7k $\Omega$ $\frac{1}{2}$ watt metal film	4.7k $\Omega$ $\frac{1}{2}$ watt metal film	150 $\Omega$ 6 watt to 390 $\Omega$ 12 watt wirewound
10-0-10V at 50-0-50 to 25-0-25mA	10V at 50 to 25mA	1k $\Omega$ 1 watt metal film	680 $\Omega$ $\frac{1}{3}$ watt carbon film	680 $\Omega$ $\frac{1}{3}$ watt carbon film	100 $\Omega$ 3 watt to 150 $\Omega$ 6 watt wirewound
6-0-6V at 25-0-25mA		470 $\Omega$ $\frac{1}{3}$ watt carbon film	100 $\Omega$ $\frac{1}{3}$ watt carbon film	100 $\Omega$ $\frac{1}{3}$ watt carbon film	100 $\Omega$ 3 watt wirewound

Set the I.F. input to the module at 100.000kHz, 50mV emf, frequency modulated at 50Hz with a peak-to-peak deviation of 85Hz. Connect the appropriate supply voltage to Pins 86 and 87 and check that a square wave with an amplitude of approx. 2.5V less than the supply voltage is present on Pin 84 with printer disconnected. Slight adjustment of input frequency and of RV14 should change the mark-space ratio over nearly the full range. Repeat the check with 150Hz modulation at 150Hz peak-to-peak deviation. Check that the mark-space ratio remains sensibly constant when the I.F. input is increased to 100mV emf.

### Voltage Analysis

The following voltages should be present, subject to usual tolerances to take account of manufacturing spreads in component values.

#### a. Input and Pulse Shaping Circuits.

IC31	Pin 1	+ 4.3V	
	5	+ 1.4V	
	12	+ 3.7V	
	13	+ 9.5V	
IC32	Pin 2	+ 4.7V )	With TP 'C' set at 5.5V
	3	+ 4.7V )	by RV13
	6	+ 5.5V )	
IC33	Pin 2	+ 5.5V	
	3	4-7V	Set by RV14. Output switches at 5.5V.
	6	+ 8.5V	"High" state
	or	+ 2.5V	"Low" state
	7	+ 9.5V	
IC34	Pin 2	8.5V	TP 'D' high
	or	4.9V	TP 'D' low
IC35	Pin 1	5.0V	TP 'D' high
		2.5V	TP 'D' low

For Service Manuals Contact  
**MAURITRON TECHNICAL SERVICES**  
 8 Cherry Tree Rd, Chinnor  
 Oxon OX9 4QY  
 Tel:- 01844-351694 Fax:- 01844-352554  
 Email:- enquiries@mauritron.co.uk

#### b. Output Switching Network.

Voltages measured with respect to -80V line. Avo 8 on 25V or lowest available range DC.

	+80V pin 86		-80V pin 86	
	Output high	Output low	Output high	Output low
IC34 pin 4	0.8V	1.5V	1.6V	1.5V
pin 5	7.0V	2.1V	1.6V	1.0V
IC35 pin 5	1.6V	1.0V	7.0V	2.1V

TR81 collector	160V	1.0V	160V	1.0V
emitter	0.6V	0.6V	0.6V	0.6V
TR82 collector	160V	160V	160V	160V
base	160V	1.0V	160V	1.0V
emitter	160V	0.6V	160V	0.6V
TR83 collector	0.6V	0.8V	0.6V	0.6V

Note IC34 pin 4; IC35 pin 4; TR81 base are common  
 TR81 collector; TR82 base; TR83 base are common  
 TR82 emitter, TR83 emitter are common.

Components List.

For Service Manuals Contact  
 MAURITRON TECHNICAL SERVICES  
 8 Cherry Tree Rd, Chinnor  
 Oxon OX9 4QY  
 Tel: 01844-351694 Fax: 01844-352554  
 Email: enquiries@mauritron.co.uk

Semiconductors.

TR81	2N3439	D81	BZY88 C9VI
TR82	2N3439	D82	BZY88 C9VI
TR83	2N5416	D83	BZY88 C3V3
		D84	BZY88 C3V3
IC31	MCI357	D85	BZY88 C6V2
IC32	741P	D86	BZY88 C6V2
IC33	741P	D87 - D94	1N4004
IC34	MCT2		
IC35	MCT2		

Coils

L33 Discriminator coil Part No. D5032  
 CH32 100mH choke Part No. 7350P

Capacitors

C651	0.1µF	Polycarbonate	20%	160V
C652	0.1µF	Polycarbonate	20%	160V
C653	0.22µF	Polycarbonate	10%	160V
C654	100pF	Polystyrene	2%	63V
C655	0.22µF	Polycarbonate	10%	160V
C656	4.7nF	Polystyrene	2%	63V
C657	4.7nF	Polystyrene	2%	63V
C658	68pF	Polystyrene	2%	63V
C659	1µF	Tantalum Electrolytic	20%	35V
C660	0.1µF	Polycarbonate	20%	160V
C661	22µF	Tantalum Electrolytic	20%	16V
C662	22µF	Tantalum Electrolytic	20%	16V

C663	22 $\mu$ F	Tantalum Electrolytic	20%	16V
C664	22 $\mu$ F	Tantalum Electrolytic	20%	16V
C665	22 $\mu$ F	Tantalum Electrolytic	20%	16V
C666	1 $\mu$ F	Tantalum Electrolytic	20%	35V
C667	1 $\mu$ F	Tantalum Electrolytic	20%	35V
C668	22 $\mu$ F	Tantalum Electrolytic	20%	16V
C669	22 $\mu$ F	Tantalum Electrolytic	20%	16V
C670	1nF	Disc Ceramic	20%	500V
C671	0.1 $\mu$ F	Polycarbonate	20%	250V

## Resistors

R651	390
R652	220
R653	100
R654	120
R655	22k
R656	6.8k
R657	1k
R658	1k
R659	6.8k
R660	6.8k
R661	6.8k

R662	68k
R663	680
R664	470k
R665	680
R666	1k
R667	1.5k
R668	22k
R669	220
R670	330
R671	10k

All the above are 5%, 1/3 W carbon film.

for the values and rating of R672, R673, R674 and R329 see table. 5% tolerance is adequate.

## Potentiometers.

RV13	1k $\Omega$	Cermet preset
RV14	1k $\Omega$	moulded track preset

For Service Manuals Contact  
**MAURITRON TECHNICAL SERVICES**  
 8 Cherry Tree Rd, Chinnor  
 Oxon OX9 4QY  
 Tel:- 01844-351694 Fax:- 01844-352554  
 Email:- enquiries@mauritron.co.uk

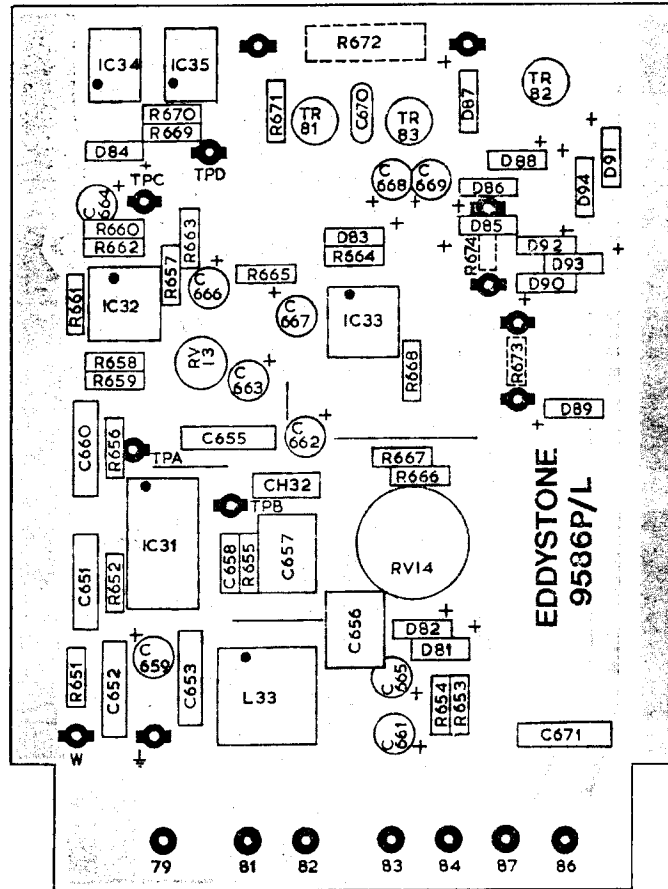

Cat. No. I533 FSK MODULE Printed Circuit Board

For Service Manuals Contact  
MAURITRON TECHNICAL SERVICES  
8 Cherry Tree Rd, Chinnor  
Oxon OX9 4QY  
Tel:- 01844-351694 Fax:- 01844-352554  
Email:- enquiries@maurtron.co.uk

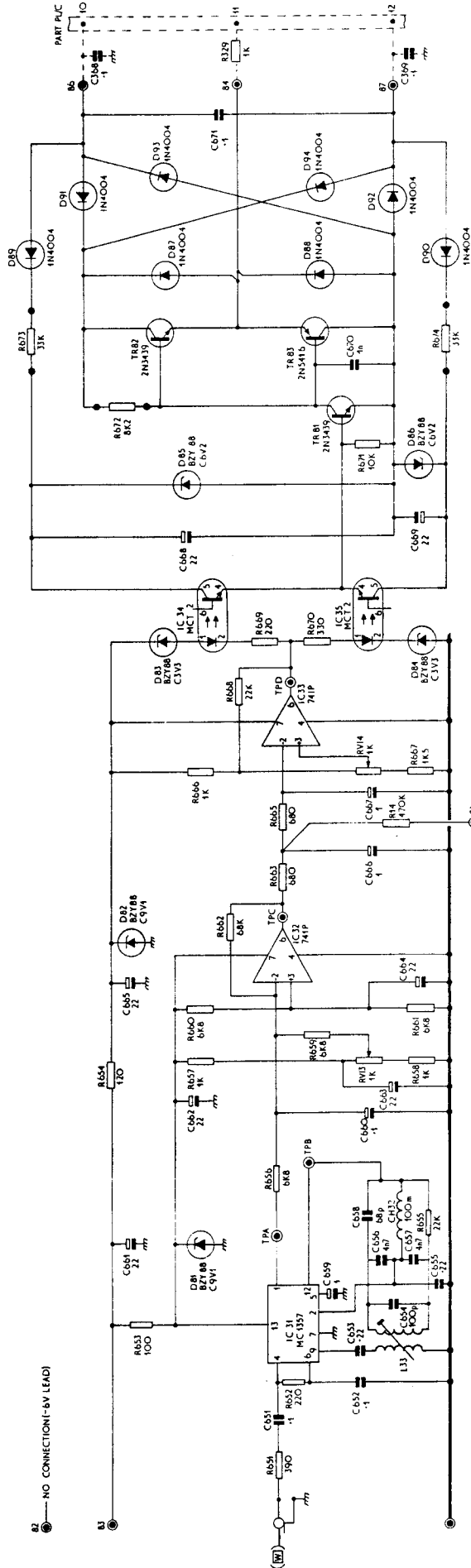

For Service Manuals Contact  
 MAURITRON TECHNICAL SERVICES  
 8 Cherry Tree Rd, Chinnor  
 Oxon OX9 4QY  
 Tel:- 01844-351694 Fax:- 01844-352554  
 Email:- enquiries@mauritron.co.uk

Cat. No. 1533 FSK MODULE CIRCUIT DIAGRAM. BP 1385

AMENDMENT NO. 12 MODEL 958

MASTER OSCILLATOR UNIT

ADD capacitor 0.1 $\mu$  polycarbonate 20% 100V Wkg (designated C122a). This capacitor is connected across circuit board terminal "I" and EARTH.

FSK MODULE (CAT 1533 ONLY)

CHANGE value of Resistor R329 (original value 1K8) to 1K w.w 12W 5%. The resistor is connected from FSK circuit board terminal "84" to Pin 11 of the Ancillary Connector.

For Service Manuals Contact  
MAURITRON TECHNICAL SERVICES  
8 Cherry Tree Rd, Chinnor  
Oxon OX9 4QY  
Tel: 01844-351694 Fax: 01844-352554  
Email: enquiries@mauritron.co.uk

## GENERAL DESCRIPTION

The EDDYSTONE Model EC958 is a solid-state communication receiver expressly designed for professional use in the range 10kHz to 30MHz, with provision for high-stability working at frequencies above 1.6MHz. Reception facilities cover CW, MCW, AM (DSB) and SSB in A3A, A3H and A3J modes (upper or lower sideband). FSK (F1) facilities can also be arranged by fitting an optional module within the receiver proper. The receiver operates from standard AC supplies or low-voltage DC with external DC/AC converter.

Basic circuit configuration is governed by the tuning range in use, single-conversion (or double-conversion with crystal controlled 2nd Oscillator) being employed at frequencies up to 1.6MHz. Above this frequency, triple-conversion is used, the additional IF providing an incremental tuning facility which is absent on the lower frequencies. Circuit arrangements allow continuous tuning over any selected range in the high frequency band or incremental tuning in steps of 100kHz with the 1st Oscillator locked to harmonics of an oven-controlled Master Oscillator having a long-term stability of the order 1 part in  $10^7$ . Provision is made for connecting an external synthesiser when high-stability working is called for at frequencies below 1.6MHz.

The signal frequency section of the receiver employs F.E.T.'s in the RF Amplifier and Mixer Stages, resulting in excellent two-signal performance throughout the entire coverage. Double-tuned bandpass input circuits are introduced on the higher frequency ranges to maintain a high degree of image protection through to 30MHz. Delayed AGC is permanently connected to the RF Stage and a switched aerial attenuator is available for manual control of RF signal level. Adequate protection is provided against high induced voltages appearing at the aerial input and muting facilities are available when using the receiver in conjunction with an associated transmitter.

Five degrees of selectivity are provided at the final intermediate frequency (100 kHz), ranging from 400Hz for narrow-band CW to 8kHz for AM. A multi-pole crystal filter is fitted for SSB (2.4kHz bandwidth). Amplification at 100kHz is provided by four cascaded F.E.T. stages, an emitter follower being included to furnish IF output for use with ancillary equipment. Two separate AGC systems are utilised to control the RF and IF Stages, the IF AGC being brought out at the rear for convenience in diversity working.

A normal diode detector is employed for AM reception, and an F.E.T. product detector for CW and SSB. Carrier insertion in the latter mode can be derived from the normal BFO or from the quartz-controlled Master Oscillator. The tunable beat oscillator has a coverage of  $\pm 5$ kHz for CW operation.

Separate audio outputs are available for loudspeaker, headset and lines, the latter being fed from a totally independent amplifier with pre-set level control. A built-in monitor loudspeaker is provided for use where a low-level output is adequate for operational requirements. Line output can be monitored on a meter which can also be switched to serve as a carrier level indicator or centre-reading FSK monitor.

Other facilities include provision for remote tuning and the option of common oscillator control for diversity working. The receiver can be supplied to special order with a companion Panoramic Display Unit (Model EP961A) for applications where visual signal analysis is an additional requirement: when supplied in this form the installation carries the designation EPR31.

The receiver is fitted with a standard 483mm (19in) panel to suit normal racking and is also available with cabinet for use in bench-mounted installations. Shock-mounts can be fitted for mobile use and other accessories include plinth and cabinet loudspeaker units in matching style. Internal construction makes extensive use of modular techniques to facilitate servicing. Scale presentation is by means of a light projection system arranged to display only those frequencies in the immediate vicinity of the actual tune frequency.

## TECHNICAL DATA

### GENERAL

#### \* Frequency Coverage

10kHz to 30MHz in ten overlapping ranges. At frequencies above 1.6MHz, facilities are provided for either continuous tuning within the selected range or incremental tuning in steps of 100kHz.

Range 1	. . . . .	20 - 30MHz	Range 6	. . . . .	290 - 680kHz
Range 2	. . . . .	10 - 20MHz	Range 7	. . . . .	125 - 295kHz
Range 3	. . . . .	4 - 10MHz	Range 8	. . . . .	53 - 126kHz
Range 4	. . . . .	1.6 - 4MHz	Range 9	. . . . .	23 - 54kHz
Range 5	. . . . .	680 - 1650kHz	Range 10	. . . . .	10 - 23kHz

#### Intermediate Frequencies

1st IF †	::	1335kHz (nominal).	Tunable 1235-1335kHz to provide incremental facility above 1.6MHz.
2nd IF ††	::	250kHz.	
3rd IF	::	100kHz.	(†) Used on Ranges 1-4 only.
			(††) Used on Ranges 1-6 and Range 8 only.

#### Reception Facilities

CW, MCW, AM (DSB) and SSB in A3A, A3H and A3J modes with selectable sideband switching.

FSK (F1) facilities are available when optional module is fitted. Keying speeds up to 200 bauds with shifts of 85-850Hz can be accommodated.

#### Power Supplies

Single-phase AC mains 100/125 and 200/250V (40-60Hz), or low-voltage DC using external DC/AC converter. Consumption of the order 35 watts AC, 45 watts DC.

#### Input and Output Impedances

Aerial Input	::	::	75-ohms unbalanced throughout entire range. Additional 600-ohms input (balanced or unbalanced) available for use on frequencies below 1.6MHz.
Synthesiser Input	::	::	Low-impedance (to 1st Signal Mixer).
Incremental Oscillator Input/Output	::	::	Low-impedance (to provide common oscillator facility for diversity working above 1.6MHz).
IF Output (100kHz)	::	::	Low-impedance (to drive external ancillaries, e.g. Panoramic Display Unit Model EP961).
Audio Output	::	::	Loudspeaker : 3-ohms Lines : 150-ohms unbalanced, 600-ohms balanced or unbalanced. Headset : Low-impedance.

#### Semiconductor Complement

The entire circuit including the optional FSK Module makes use of 40 transistors, 56 diodes and 11 integrated circuits. The reader is referred to Appendix "C" for a complete list of types and circuit functions.

(\*) Actual limits of ranges may differ slightly from figures quoted. See Page 41.

## TYPICAL PERFORMANCE

(This data should not be interpreted as a test specification)

### Sensitivity

AM :: 3 $\mu$ V for 10dB S/N ratio (Bandwidth 3kHz).  
 CW/SSB :: 1 $\mu$ V for 10dB S/N ratio (Bandwidth 3kHz).  
 CW (below 100kHz) :: 1 $\mu$ V for 20dB SINAD (Bandwidth 1.3kHz).

### IF Selectivity

Five selectable bandwidths are provided at the 100kHz IF. Maximum overall bandwidth is determined by the front-end circuits when operating on the low frequency ranges.

Position	Overall Bandwidth		<u>SSB</u>
	-6dB	-60dB	
<u>400Hz</u>	400Hz	2.4kHz	An asymmetrical filter having a bandwidth of 2.4 kHz (3dB points) is provided for SSB reception. 60dB points lie at carrier +400Hz and carrier -3.5kHz.
<u>1.3kHz</u>	1.3kHz	4.5kHz	
<u>SSB</u>	-	-	
<u>3kHz</u>	3kHz	12kHz	
<u>8kHz</u>	8kHz	18kHz	

NB Special filters can be fitted to order.

\*carrier freq. 100kHz

### Image Rejection

10kHz-1.6MHz :: 60dB. 1.6MHz-18MHz :: 75dB. 18MHz-30MHz :: 60dB.

### IF Breakthrough

10kHz-1.6MHz :: 60dB. 1.6MHz-18MHz :: 90dB. 18MHz-30MHz :: 100dB.

### Frequency Stability

The figures quoted in the following Table are indicative of the frequency stability achieved on the low, medium and high frequency bands. The HF figures are quoted for high-stability working, in which mode a supply voltage change of  $\pm 10\%$  does not change the tune frequency by more than 2Hz.

Frequency Band	Total frequency change after 30-min. warm-up	
	With constant ambient	With 5 $^{\circ}$ C change in ambient
1.6MHz - 30MHz	Less than 20Hz (long-term)	Less than 20Hz
160kHz - 1.6MHz	Less than 1 part in 10 $^4$ in any 5-min. period	Less than 5 parts in 10 $^4$
10kHz - 160kHz	Less than 50Hz in any 5-min. period	Less than 150Hz

Cross Modulation (Wanted signal 60dB $\mu$ V)

Unwanted output will be at least 30dB below standard output with an interfering signal 20kHz off-tune and of level 90dB $\mu$ V (or 5% off-tune of level 110dB $\mu$ V in the range 1.6-30MHz).

Blocking (Wanted signal 60dB $\mu$ V)

Output will be affected by less than 3dB with an interfering carrier 20kHz off-tune of level 100dB $\mu$ V (or 3% off-tune of level 120dB $\mu$ V in the range 1.6-30MHz).

Intermodulation

With a wanted signal 30dB $\mu$ V, two unwanted signals whose sum or difference frequency equals that of the wanted signal, must each be of a level 90dB $\mu$ V to give standard output.

The level of third-order intermodulation products given by two signals of equal strength lying at carrier + 1kHz and carrier + 1.6kHz will be at least 30dB below the level of either signal.

AGC Characteristic

Output is maintained within 6dB for a change in input of 90dB from 3uV reference level.

AGC Time Constant

Dependent on setting of Mode Switch. Of the order 40 milliseconds charge, 1 second discharge at 'AM' & 'CW/SSB'. Increased to 200 milliseconds and 10 seconds respectively when switched to 'SSB HIGH-STAB'.

Audio Output

1W in 3-ohms at 5% distortion. (Low-level o/p also available from small built-in monitor speaker.)

10mW in 600-ohms with independent pre-set level control.

Audio Response

Level within 3dB over the range 300Hz to 4kHz.

IF Output

20mV in 75-ohms for 3uV carrier at aerial input.

Radiation

Typically 20uuW and not greater than 400uuW at any frequency.

Operational Temperature Rating

0-50°C.

Calibration Accuracy

Frequency can be read to 200Hz on High-Freq. ranges when using incremental tuning.

Remote Fine Tuning

100Hz above and below local tune frequency. This facility is available on Ranges 1-4 only.

## CIRCUIT DESCRIPTION

### GENERAL

The EC958 Receiver operates as a single, double or triple-conversion superhet depending on the actual tuning range in use. Selection of the appropriate IF configuration is an auxiliary function of the range switching and is fully automatic. Details of the basic circuit arrangement applicable to each of the ten tuning ranges are given in the Table below. It should be noted that in order to avoid confusion in the text which follows, intermediate frequencies will henceforth be referred to as "The Tunable IF", "The 250kHz IF" and "The 100kHz IF". Further reference to intermediate frequencies as "The 1st IF" etc. will be avoided wherever possible.

#### FREQUENCY CONVERSION ARRANGEMENTS : RANGES 1-10

Range	Coverage	Conversion	IF1	IF2	IF3
1	20 - 30MHz	) Triple	Tunable 1235-1335kHz	250kHz	100kHz
2	10 - 20MHz				
3	4 - 10MHz				
4	1.6 - 4MHz				
5	680 - 1650kHz	Double	250kHz	100kHz	-
6	290 - 680kHz	Double	250kHz	100kHz	-
7	125 - 295kHz	Single	100kHz	-	-
8	53 - 126kHz	Double	250kHz	100kHz	-
9	23 - 54kHz	Single	100kHz	-	-
10	10 - 23kHz	Single	100kHz	-	-

Availability of the tunable IF on the four high frequency ranges provides an incremental tuning facility which is absent on the other ranges. A coverage of 100kHz is given by the INCREMENTAL TUNING CONTROL, scale calibration being directly readable to within 200Hz. Additionally, provision is made on Ranges 1-4 for operating the receiver as a high-stability receiver, with its 1st Local Oscillator (referred to as the "Main-Tune Oscillator") driving a drift-cancelling loop locked to harmonics derived from an oven-controlled Master Oscillator.

In this mode of operation, all tuning is carried out with the INCREMENTAL TUNING CONTROL, after initial setting of the MAIN TUNING CONTROL to the 0.1MHz calibration point at the low edge of the 100kHz segment in which the required signal frequency lies. An illuminated legend (reading 'HIGH-STAB') indicates correct setting of the MAIN TUNING CONTROL and shows also that the drift-cancelling loop is operative. A Crystal Calibrator is incorporated to permit accurate setting of the tuning scale on the higher frequency ranges. Markers are available at 1MHz intervals through to 30MHz and an adjustable cursor line is provided for error correction.

The various sections of the receiver will now be considered in detail, commencing at the aerial input. Frequent reference should be made to the Block Diagram at the rear so that the reader obtains a clear understanding of the basic circuit action before studying the circuit proper.

## THE RF SECTION

This description will ignore initially the provision made for high-stability operation on the high frequency ranges and will concentrate on the more conventional aspects of the circuit design. A full description of the circuitry involved in the drift-cancelling loop is included later in this Section.

The whole of the RF Section is built into a rugged die-cast housing which provides extensive screening and involves a total of six separate printed circuit boards. Range selection is achieved by means of a unique printed circuit turret arrangement in which all inductors together with associated trimmers etc. are carried on 4.25 in. diameter disks which are rotated by the range selector mechanism. Six disks are required, two of which are associated with the drift-cancelling circuitry. Five standard type switch wafers are ganged to the turret mechanism, these being used to carry out associated switching functions such as selection of the appropriate IF channel etc.

### The RF Amplifier and 1st Signal Mixer

An n-channel junction FET (TR1 :: UC734B) and an n-channel single-gate MOSFET (TR2 :: 3N128) are combined to produce a low-noise cascode RF Amplifier with extremely good two-signal performance. A delayed RF AGC line is permanently connected to this stage, connection being to the gate of the second transistor.

The signal frequency input circuit arrangements vary with the actual range in use, the major difference being that two bandpass-coupled circuits are employed on the four high frequency ranges, whereas on the other bands a single circuit only is used. Coupling between the two bandpass circuits on Ranges 1 & 2 is by means of the earth return inductance present on the RF Disk (Disk "B"). On Ranges 3 & 4, low inductance link windings provide the coupling required (L46, L47).

IF rejection filters are brought into circuit automatically by the disk switching, parallel rejectors being employed for Ranges 5, 6, 7 and 8 and a high-pass filter on Range 4 (L40/L41). Rejection Filters are not required on Ranges 1-3, 9 & 10. All rejectors are located on the Aerial Disk (Disk "A").

A three-position aerial attenuator is included in the aerial input circuit, this giving a maximum attenuation of 20dB and serving as a form of manual RF gain control. RLA/1 is arranged to interrupt the aerial feeder and short down the receiver input circuit when energised from an external send/receive control system. The relay is a high-speed reed type and can be operated from a 12V or 24V supply. Connections are available on the ancillary connector (PL/C) at the rear of the set. RLA/1 is also energised (via S1) to prevent interference from outside signals when carrying out a calibration check.

Aerial protection diodes (PC1 :: 8 x 1N4148) are included to guard against damage to the input transistor etc. due to high induced aerial voltages caused by lightning strikes etc. The normal aerial input impedance is nominally 75-ohms, but the balun T1 allows use of 600-ohm feed at all frequencies up to 1.6MHz.

Simple tuned-secondary transformer coupling is used between the RF Amplifier and the 1st Signal Mixer Stage on all ranges except 7, 9 and 10. On these ranges, a form of resistance-capacity coupling is employed to the tuned input circuit of the following stage (L60, L62 & L63).

A dual-gate n-channel MOSFET is used as the 1st Signal Mixer, with signal input to gate 1 and oscillator injection to gate 2. The drain of the Mixer is taken via coaxial interconnection "E" to the selector of S3C (part of the RANGE SWITCH), and thence to the appropriate IF channel.

## Signal-frequency Tuning

All signal-frequency circuits are gang-tuned by the MAIN TUNING CONTROL, one section of which becomes idle on Ranges 5-10 when bandpass input tuning is not employed. Six voltage-variable-capacitance diodes (D5-D10 :: 6 x BA111) are wired "back-to-back" in pairs across each of the three gang sections to permit independent adjustment of the signal-frequency circuits when using the incremental tuning facility. Only two of the diodes (D7 & D8) are operative on Ranges 5-10, functioning as a conventional aerial trimmer control in parallel with the aerial section of the main tuning gang (C31).

The diodes are reverse-biased from RV1, and the circuit is so arranged that the effective capacity swing is modified to suit the signal-frequency range in use (S3A selects R20, R21, R22 or R23 as appropriate).

Note that on Ranges 1 and 2, the DC return for the VVC's is completed by 0.1-Megohm resistors which are included in the Aerial, RF and Signal Mixer Disk circuitry (R350/351 :: Turret Disk "A" - R360/361 :: Turret Disk "B" - R370/371 :: Turret Disk "C"). This arrangement is necessary because of the inclusion of series tracking capacitors (C381 etc.) on these two ranges.

## Main-Tune Oscillator (1st Local Oscillator)

This stage utilises a single-gate MOSFET (TR4 :: 3N128) in a tuned-gate oscillator circuit, with separate feedback winding in series with the feed to the drain electrode. It is tuned by a further section of the main tuning gang (C46) which has wider spacing and heavier vanes than the signal frequency sections. A gate resistor and biasing diode are used in conjunction with a source resistor to determine the operating point. Output is taken by capacitive coupling from the gate to an n-channel junction FET (TR5 :: UC734B) which is wired as a source follower and serves as an isolating stage. Injection voltage is capacitively coupled to the second gate of the 1st Signal Mixer via the series connected capacitors C54 and C43. The junction of these two capacitors is wired to a coaxial connector on the back plate to facilitate connection of external oscillator drive for synthesised operation. The miniature toggle switch S4 allows the +12V supply to be removed from TR4 and TR5 when using the receiver in this manner.

The VVC diode D11 (BA110) forms part of the oscillator tuned circuit and is maintained at constant effective capacity except when using the receiver in its high-stability mode. Its function will be covered later in this Section.

## 1MHz Crystal Calibrator

A linear integrated circuit (IC1 :: CA3000/V1) serves as the 1MHz oscillator for scale checking. Its use is restricted primarily to verification of the MHz calibration marks on the highest frequency ranges, but it can of course be used to check the accuracy of calibration at any frequency higher than 1MHz. Scale correction is achieved by mechanical movement of the scale cursor index line.

The Calibrator output is coupled into the RF Section by a small probe positioned close to the Cascode RF Amplifier.

## Supply Voltages

The Crystal Calibrator and the two FET's in the Local Oscillator circuit are fed from a regulated +12V supply. The RF Amplifier and 1st Signal Mixer operate from a regulated +15V supply.

## THE TUNABLE IF

This portion of the receiver is operative only when using Ranges 1-4 (1.6-30MHz). It comprises the following stages and is fed from the drain of TR3 via the RANGE SWITCH wafer S3C and coaxial interconnections "E" & "J".

TR15	2nd Signal Mixer
IC12	2nd Loop Mixer (Part of the drift-cancelling loop)
TR17	Incremental Oscillator (550-650kHz)
TR18	Emitter Follower
TR19	Emitter Follower (Not operative on standard EC958 Receiver)
IC5	935kHz Crystal Oscillator

The Tunable IF coverage is 1235-1335kHz, and all frequencies in this range are converted directly to the 250kHz IF in the 2nd Signal Mixer. Oscillator injection is derived from IC12 which pre-mixes the outputs of the Incremental Oscillator (550-650 kHz) and the 935kHz Crystal Oscillator (IC5) to provide drive in the frequency band 1485-1585kHz.

The pre-mixing technique allows the Incremental Oscillator to be run at roughly one-third of the required injection frequency, so contributing considerably to the very high stability of this stage. Scale calibration is substantially s.l.f. with sensibly constant tuning rate over the 100kHz range. Actual coverage is 548-652kHz to provide a slight overlap when using the receiver in the incremental mode.

The nominal frequency for the Tunable IF (i.e. that to which it is set during test when aligning the signal frequency and main-tune oscillator circuits) is 1335kHz. The incremental tuning scale reads '0' at this setting which must be used to preserve the main scale calibration accuracy when tuning the receiver solely by means of the MAIN TUNING CONTROL. The Tunable IF lies at 1235kHz when the incremental scale reads 100, this corresponding to an effective signal frequency 100kHz higher than that indicated on the main tuning scale. Note that the Tunable IF is tuned lower in frequency to obtain a higher effective tune frequency.

Consider the example below in which it is assumed that the receiver is set initially to 3.5MHz with the incremental scale at its '0' setting.

<u>Signal Frequency</u>	3500kHz
<u>Tunable IF Frequency</u> (nominal setting)	1335kHz
<u>Main-Tune Oscillator Frequency</u> (3500 + 1335)	4835kHz

The effective signal frequency for a setting of 50 on the incremental scale will be 3.55MHz, provided the main scale setting is maintained at 3.5MHz. This can be shown as follows :-

<u>New Tunable IF Frequency</u> (1335 - 50)	1285kHz
<u>New Signal Frequency</u> (4835 - 1285)	3550kHz

Operationally of course, it is only necessary to add the incremental reading to that on the main scale to determine the effective tune frequency.

### 2nd Signal Mixer (TR15)

A further 40673 dual-gate MOSFET is employed in this position, using an almost identical configuration to that found in the 1st Signal Mixer Stage, i. e. signal (IF) input to gate 1 and oscillator injection to gate 2. A three-circuit voltage-variable-capacitance-tuned bandpass filter (L13, L14 & L15) is included between the oscillator pre-mixing stage (IC12) and gate 2 of the 2nd Signal Mixer. This covers the band 1485-1585kHz, the diodes D22/22A, D23/23A & D24/24A (6 x MV1656) being controlled by the potentiometer RV3 which is ganged to the incremental tuning mechanism. Adequate selectivity is provided to discriminate against spurious mixing products due to the pre-mixed oscillator drive.

Six more diodes (D19/19A, D20/20A & D21/21A) tune the three-circuit IF filter L10, L11 & L12 over the intermediate frequency band 1235-1335kHz. Bandwidth is restricted to some 15kHz to limit cross modulation effects at the 2nd Signal Mixer. Pre-set potentiometers RV4 and RV18 are adjusted during test to provide correct tracking of the VVC-tuned circuits.

Output from the drain of TR15 is fed directly to the 250kHz IF filter via the coaxial interconnecting lead "P".

### 2nd Loop Mixer (IC12)

This stage forms part of the drift-cancelling loop employed for high-stability working, but is also operative for normal operation on the four high-frequency ranges. The circuit uses a double-balanced mixer (IC12 :: SL641C) with drive from the two oscillator sources taken separately to inputs 3 and 7. 935kHz drive is to input 7 via coaxial interconnecting lead "M", and Incremental Oscillator drive to input 3 via interconnection "N". Input levels are set to optimum values by adjustment of C154/155 and C157 during factory test.

### Incremental Oscillator Unit (TR17, TR18 & TR19)

TR17 (UC734B junction FET) serves as the Incremental Oscillator proper, while TR18 and TR19 (2 x 2N4254) are wired as isolating emitter followers to provide two separate low-impedance outputs. TR19 is not operative in the basic EC958 Receiver, but is used in some variants. A low-pass filter (L17/L18) is included in the main output.

The oscillator circuit is of the tuned-gate variety, tuned by a high-quality straight-line-frequency tuning capacitor: feedback is from a separate winding in series with the drain circuit. Temperature compensation is employed to give long-term stability of the order 20Hz or better. Provision is made for fine tuning by inclusion of the VVC diode D46 (BA111) which allows shifts of  $\pm 100$ Hz by means of an external control which can be located remotely at a distant listening point.

Pre-set potentiometer RV17 provides fine adjustment of the VVC-diode control voltage to permit correction for long-term ageing of the oscillator components. The control is marked 'INC CAL' and located on the panel for screwdriver adjustment.

Extensive zener regulation is employed for the oscillator supply which operates at a final voltage of 8.2V. Four zener diodes are cascaded to provide this voltage, namely D42, D41, D26 and D25. The 12V supply is maintained on all ranges to allow the oscillator to run continuously in the interest of optimum stability.

Circuit arrangements are such that one Incremental Oscillator Unit can be used to control two receivers in a diversity set-up. The NORMAL/SLAVE SWITCH (S6) allows the +12V supply line to be interrupted when not required.

### 935kHz Crystal Oscillator (IC5)

This stage is operative only on the four HF ranges, and only then when operating in the 'CONT TUNE' position. It makes use of a linear integrated circuit (IC5 :: CA3000/V1) with a close-tolerance crystal (XL2) running in series mode. Output is capacitively coupled via C103, C91 and C154/155 to input 7 on IC12 as described earlier. The +12V supply is fed via S3D (part of RANGE SWITCH) and S5B (part of HIGH-STAB/CONT TUNE SWITCH).

## HIGH-STABILITY OPERATION ON RANGES 1-4 (1.6-30MHz)

It is convenient at this point to consider operation of the drift-cancelling loop employed for high-stability working on the HF ranges. In this mode of operation, the Incremental Oscillator provides 550-650kHz drive to the 2nd Loop Mixer exactly as described on page 13. 935kHz drive however, is now derived from the 1st Loop Mixer (TR7), the normal 935kHz Crystal Oscillator being disabled by S5B. Output from the 1st Loop Mixer results from heterodyning the Main-Tune Oscillator (OSC 1) frequency with an appropriate harmonic delivered by an oven-controlled Master Oscillator. The harmonic will be a multiple of 100kHz and is always selected to lie 400kHz higher than the chosen 0.1MHz calibration point to which the MAIN TUNING CONTROL is set. (Note : It is essential to the working of this system that the MAIN TUNING CONTROL is adjusted in steps of 100kHz, interpolation between adjacent points being by means of the incremental facility.

Consider now the example set out below in which it is assumed that the MAIN TUNING CONTROL is set to 3.5MHz.

<u>Signal Frequency</u>	3500kHz
<u>Intermediate Frequency</u> (Nominal value with INCREMENTAL at '0')	1335kHz
<u>Main-Tune Oscillator Frequency</u> (Signal + IF) = (3500 + 1335)	4835kHz
<u>Selected Harmonic of 100kHz</u> (Signal + 400kHz) = (3500 + 400)	3900kHz
<u>Resultant Output from 1st Loop Mixer</u> (4835 - 3900)	935kHz

Any shift in Main-Tune Oscillator frequency will now be transmitted not only to the 1st Signal Mixer, but also to the 2nd Signal Mixer. Continuing the example above, and assuming the Main-Tune Oscillator to have moved 2kHz higher in frequency :-

<u>New Main-Tune Oscillator Frequency</u> (4835 + 2)	4837kHz
<u>New Intermediate Frequency</u> (4837 - 3500)	1337kHz
<u>New Loop Frequency</u> (4837 - 3900)	937kHz

Injection to the 2nd Signal Mixer is therefore also 2kHz higher than previously, lying at (650 + 937)kHz = 1587kHz. The effective intermediate frequency in the Tunable IF becomes (1587 - 250)kHz = 1337kHz which coincides with the new IF produced by conversion of the 3500kHz signal in the 1st Signal Mixer Stage. Drift has therefore been cancelled completely, the process of course being absolutely instantaneous.

The maximum drift which can be accommodated by the loop system is dependent on the bandwidth of the 935kHz circuits and amounts to roughly  $\pm 5$ kHz. Drift in excess of this would result in severe reduction in injection level to the 2nd Signal Mixer, so causing loss of conversion efficiency. This is overcome by introducing a simple AFC system to hold the Main-Tune Oscillator frequency well within the passband of the 935 kHz Stages. Control for the AFC arrangement is derived from a discriminator operating at the centre-frequency of the loop system. Switching is by S5C.

The various stages concerned in the drift-cancelling loop will now be considered in greater detail.

## The Master Oscillator Unit

This unit provides two independent outputs, one being at 100kHz to provide carrier insertion in the CW/SSB Detector, and the other a differentiated spike output which contains all harmonics of 100kHz up to at least 30.4MHz.

Both outputs are derived from a 1MHz oven-controlled crystal oscillator provided with an easily accessible trimmer to permit precise frequency setting during test and alignment. Output from the oscillator is fed to the base of TR12 (2N4254) which increases the level of the 1MHz signal and drives the integrated circuit IC6 (FJJ141). This stage functions as a decade divider, input being limited by the diode D17 (BZY88 C4V7), which prevents overdrive of the integrated circuit.

The square-wave output at 100kHz is fed to the bases of TR13/14 (BC107B & 2N4254) which are wired as emitter followers. TR13 has a tuned input circuit and therefore gives a good sine-wave output at 100kHz. It is this output which provides carrier insertion for SSB reception when the MODE SWITCH is set to 'SSB HIGH-STAB'.

The other emitter follower (TR14), is driven directly from the decade divider and can be considered as an harmonic generator which feeds all harmonics of 100kHz to the harmonic selector circuits which form part of the RF Section.

The Master Oscillator Unit has been arranged to run continuously on all ranges to ensure that the 100kHz carrier insertion signal is available for SSB reception on Ranges 5-10. The main stages in the unit are connected directly to the +12V regulated supply, but the carrier insertion emitter follower TR13 is supplied via one section of the SIGNAL MODE SWITCH (S10C). This feed is completed with the switch set to 'SSB HIGH-STAB', and additional switching of the carrier insertion signal occurs in the signal path proper (see later). The main Master Oscillator output is also available on all ranges, but is utilised only on Ranges 1-4. On the other six ranges, the absence of tuned circuits on Disks E & F prevents passage of the signal through TR6 to TR7.

The Master Oscillator Unit is housed in a double-screened box to prevent direct radiation of its harmonic output within the receiver. Double-screened coaxial lead is used to extend this protection on the main output connection. The carrier insertion output is run with standard single-screened coaxial cable. Output leads are coded "G" (harmonic drive) and "I" (carrier insertion).

## Harmonic Amplifier (TR6)

The output derived from TR14 in the Master Oscillator Unit contains components of all 100kHz harmonics and is fed to an amplifier stage (TR6 :: UC734B FET) which forms part of the main RF Assembly. The input to the FET is tuned over the range 2.0-30.4MHz by a further section of the main tuning gang (C60). The appropriate inductors are carried on Turret Disk "F", the circuits being tracked to tune 400kHz higher than the indicated signal frequency on the main tuning scale. It is at this point in the circuit that the desired harmonic is selected.

A low-impedance winding in the drain of TR6 couples the selected harmonic to a second "harmonic-selector" circuit tuned by C65 which reinforces the attenuation of unwanted harmonics afforded by the first circuit. All inductors etc. are carried on Turret Disk "E".

### 1st Loop Mixer and Main-Tune Oscillator Amp (TR7 & IC2)

The second "harmonic-selector" circuit referred to at the foot of the previous page, is wired to gate 1 of the 40673 which serves as the 1st Loop Mixer. Gate 2 is fed from the Main-Tune Oscillator (OSC 1) via a wideband amplifier (IC2) driven from the drain of TR4. The difference between the two applied frequencies appears in the drain circuit of TR7 in which the load comprises L1/C70 tuned to 935kHz. Output at this frequency is taken from a tap on L1 via coaxial interconnecting lead "H". Output will only be available at discrete settings of the MAIN TUNING CONTROL, i.e. every 100kHz.

IC2, TR6 and TR7 are fed from the +15V line via S5A (part of the HIGH-STAB/CONT TUNE SWITCH) and are only operative at the high-stability settings of this switch. (Note : These stages are not interlocked with the range switching and can therefore be brought into operation on any range. They are however, non-functional except on Ranges 1-4).

### The 935kHz Loop Stages (IC3, IC4, TR8, TR9, TR10 & TR11)

Output from the 1st Loop Mixer (TR7) is coupled to a double-tuned bandpass circuit (L2/L3) aligned at 935kHz and feeding the integrated circuit IC3 (CA3002/V1). This stage functions as the main loop amplifier, its output feeding the emitter follower TR9 (2N4254) via a second 935kHz double-tuned bandpass circuit. The emitter follower drives a detector circuit (D15 :: 1S44) which serves to control the Schmitt Trigger TR10/11 (UC734B/40309) to operate relay RLB/1. The relay operates to close contact B.1 whenever 935kHz drive is available from the 1st Loop Mixer. Closure of the contact applies +12V to LP1 which illuminates the 'HIGH-STAB' legend on the panel to indicate to the operator that the MAIN TUNING CONTROL has been set correctly - i.e. the appropriate 100kHz harmonic has been selected by the harmonic selector circuits and passed on to TR7. The trigger circuit ensures fast operation of the lamp relay when the drive is above the level required for satisfactory mixing.

A further 935kHz tuned circuit (L6/C93) is coupled to the bandpass pair in the output of IC3. Coupling is by C91, output from this point being taken to drive the 2nd Loop Mixer IC12 via coaxial interconnection "M".

It should be noted that the 935kHz Crystal Oscillator IC5 is coupled into this circuit via C103 to simplify the switching operations involved in changing from 'CONT TUNE' to 'HIGH-STAB' working.

A tap on L6 also feeds the integrated circuit IC4 (CA3012/V1) which functions as a limiter to drive the AFC Discriminator D13/14 (2 x 1S44). The DC voltage appearing across the load resistors R81/82 under off-tune conditions is applied via R83 to the gate of TR8 (UC734B). This stage is used to control the AFC diode (D11) in the Main Tune Oscillator circuit, but is only brought into operation after initial setting of the MAIN TUNING CONTROL to illuminate the 'HIGH-STAB' indicator.

Switching is accomplished by S5C which disables TR8 by earthing its gate. RV2 is adjusted during final alignment to set the standing reverse-bias to D11, the +12V supply being retained on TR8 at all times since D11 is always present as an active element of the Main-Tune Oscillator circuit.

### High-Stability/Continuous Tune Switching (S5A-C)

Selection of the desired mode of operation on the four HF ranges is achieved by use of the HIGH-STAB/CONT TUNE SWITCH. This has three positions marked as follows :-

OPERATE	SET	CONT
<input type="checkbox"/>	<input type="checkbox"/>	<input type="checkbox"/>
<input type="checkbox"/>	<input checked="" type="checkbox"/>	<input type="checkbox"/>
<input type="checkbox"/>	<input type="checkbox"/>	<input type="checkbox"/>

The 'CONT TUNE' position disables the drift-cancelling loop and permits normal tuning over any selected range by use of the MAIN TUNING CONTROL. The INCREMENTAL TUNING CONTROL is also operative in this position, and though normally set to '0' to preserve the main scale calibration, can be used for "fine" tuning if so desired.

Shifting the switch to 'SET' will activate the whole of the drift-cancelling loop but not the AFC arrangement associated with the VVC diode D11. The MAIN TUNING CONTROL is adjusted in this position of the switch to cause the 'HIGH-STAB' indicator to become illuminated when set to the desired 0.1MHz calibration mark on the main scale.

Once this operation has been completed, the switch is moved to 'OPERATE' to introduce the AFC system. Under this condition of operation, frequency change in the Main Tune Oscillator is limited to minor tracking excursions in the AFC loop.

The three sections of S5 perform the following functions :-

S5A Completes the +15V supply to the Main-Tune Oscillator Amp. (IC2), the Harmonic Amplifier (TR6) and the 1st Loop Mixer (TR7) when set to either of the 'HIGH-STAB' positions.

S5B Completes the +12V supply to the 935kHz Crystal Oscillator (IC5) at 'CONT TUNE' and disables this stage at 'SET' and 'OPERATE'. The 12V supply is transferred to the other 935kHz stages in these two positions to permit operation of the drift-cancelling loop. It should be noted that the +12V line is routed via S3D (part of RANGE SWITCH) and is present only on Ranges 1-4.

S5C Earths the gate of TR8 (AFC Control Amp.) in all positions except 'OPERATE' to stop the AFC working during normal tuning and setting up operations.

#### THE 250kHz IF

This portion of the receiver is operative on all ranges except Ranges 7, 9 & 10. 250kHz input is derived from either the 1st or 2nd Signal Mixer dependent on the actual range in use. On Ranges 1-4 (when the Tunable IF is used), input is taken direct from the drain of the 2nd Signal Mixer (TR15) via coaxial interconnection "P". On Ranges 5, 6 & 8, the drain of the 1st Signal Mixer (TR3) is switched in parallel with the drain of TR15 via S3C and the coaxial interconnection "K". Supplies remain on the 2nd Signal Mixer on Ranges 5, 6 & 8, but there is no input to this stage due to interruption of the circuit at S3C.

The +12V supply is completed to the 3rd Signal Mixer (TR20 :: 40673) by S3D, directly on Ranges 5, 6 & 8, but via the diode switch D31/1N4004 on Ranges 1-4. D31 ensures that the +12V supply applied via pin 38 of the 250kHz IF Module does not appear on the line to S5B (via SK/A-5) when using Ranges 5, 6 & 8.

Selectivity at the 250kHz IF is provided by an eleven-element ceramic ladder filter which feeds the 3rd Signal Mixer via the 250kHz IF Amplifier TR22 (BC107B).

The associated local oscillator system comprises IC7 and TR21 which provide crystal-controlled oscillator injection at either 150kHz or 350kHz dependent on the position of the USB/LSB SWITCH S7A.

IC7 (CA3000/V1) functions as a dual crystal oscillator, selection of the appropriate crystal (XL3 or XL4) being achieved by the diodes D27 & D28 (2 x 1S44). Either diode can be forward-biased from the -6V line via S7A so as to effectively ground the feedback paths through either C204 or C205. The circuit with the un-grounded feedback oscillates, RF appearing at the diode causing it to become reverse-biased.

Output from IC7 is amplified by TR21 (UC734B) and fed to gate 2 of the 3rd Signal Mixer (TR20). 100kHz IF output is developed in the drain of this stage and passed via coaxial interconnection "Q" to the 100kHz filters. Coaxial interconnection "L" is wired in parallel with "Q" and runs from the RANGE SWITCH wafer S3C to permit connection directly from the 1st Signal Mixer to the 100kHz filters when using Ranges 7, 9 & 10.

### USB/LSB Switching

In SSB reception, output from the 3rd Signal Mixer must always be a lower sideband signal to suit the filter fitted in the 100kHz IF. This passes the speech sideband on the lower side of the carrier insertion frequency (100kHz).

Input to the 3rd Signal Mixer can be either USB or LSB, and on Ranges 1-4 will be identical to the signal at the aerial input. This is so because sideband reversal occurs twice as the signal passes through the IF system, i.e. a lower sideband signal at the aerial input, becomes an upper sideband signal at the Tunable IF, but reverts to being a lower sideband signal when converted to the 250kHz IF. The reversals are due to both 1st and 2nd Signal Mixers operating with their associated local oscillators on the high side of their respective input frequencies.

Provision is made to operate the 3rd Signal Mixer with oscillator injection either above or below the 250kHz input frequency, so providing a means of sideband reversal such that upper sideband signals can be received in a receiver having only a lower sideband filter. S7A selects the required injection frequency, the panel being marked 'USB' when the 350kHz crystal is selected and 'LSB' for the 150kHz crystal. In the latter case, the output sideband will be the same as the input sideband since reversal does not occur when the injection lies on the low side of the input frequency.

On Ranges 5, 6 & 8, the receiver functions with double-conversion, and in this case input to the 3rd Signal Mixer will bear the opposite sideband to that present at the aerial input. On these ranges, the operator must remember to read the panel legend in reverse when selecting the desired setting of the changeover switch.

A further application of S7 is to provide a means of mark/space reversal when receiving frequency-shift-keyed signals. Neither this facility, nor sideband switching is available when the receiver is used on Ranges 7, 9 & 10, since conversion is then direct from signal frequency to the 100kHz IF. It should be noted that sideband selection is instantaneous and that re-tuning is not required when switching USB/LSB.

### THE 100kHz IF

The 100kHz IF system comprises a switched L/C filter providing four selectable IF bandwidths, a multi-pole crystal filter for SSB reception, four cascaded amplifier stages and two independent AGC circuits. An emitter follower stage provides drive for separate AM and CW/SSB Detectors, the FSK Unit (when fitted), and output for use with external ancillaries.

### 100kHz Filters

Four of the five selectivity positions are determined by a five-section L/C filter comprising L24-L28. Switching is by S8A-G which introduce progressively larger values of top-coupling capacitor to provide increased coupling for the wider bandwidths. Damping resistors are switched into circuit for the two wide selectivity positions, and extra parallel capacity in the two narrow positions. Actual 6dB bandwidths are 400Hz, 1.3kHz, 3kHz and 8kHz.

High "Q" precision-wound vinkor assemblies and close-tolerance silvered-mica capacitors are used in conjunction with low-loss switching to provide an extremely compact highly efficient filter having very good skirt selectivity.

S8A routes the input feed (coaxial interconnection "Q") to the multi-pole crystal filter via coaxial interconnection "R" when set to the 'SSB' position. The filter is designed to pass lower sideband only with suppressed carrier at 100kHz. Output is taken via coaxial interconnection "S" to S8G and thence via coaxial "T" to the cascaded amplifiers TR23 etc. S8B is arranged to short the input to the L/C filter and so prevent leakthrough when using the 'SSB' position. CH36 completes the +12V feed to the appropriate mixer stage when using the SSB filter.

#### 100kHz IF Amplifiers, Emitter Follower and AM Detector

Four cascaded FET amplifiers TR23-26 (4x UC734B) are employed as the 100kHz IF Amplifier using broadly resonant coupling between each stage. Gain control is applied to the first three stages, either manually by the IF GAIN RV5 or from the IF AGC line. Switching is by the MANUAL/AGC SWITCH S9. The final 100kHz IF Amplifier feeds the emitter follower TR27 (2N4254) and the IF AGC Amplifier TR30 (UC734B).

TR27 provides a low-impedance outlet to drive the CW/SSB Detector, the FSK Unit and any external ancillaries requiring input at 100kHz. The emitter follower is matched to the AM Detector D32 (OA47) by the tapped step-up circuit L29, detected output being developed across the load R220 and routed to the 'AM' position of S10A (part of the SIGNAL MODE SWITCH).

#### RF & IF AGC Systems

Separate AGC lines are available for control of the RF Amplifier and the first three 100kHz IF Stages. The RF AGC is permanently connected and is derived from D33 (1S44). Divider R230/231 provides a delay for the diode and preserves full gain in the RF Amplifier except when handling extremely high-level signals. A similar drive arrangement to that used with the AM Detector is employed to feed the RF AGC Rectifier, utilising Emitter Follower TR29 (2N4254) and matching coil L30. TR28 (UC734B) provides the requisite amount of 100kHz amplification and is choke-capacity coupled to the emitter follower.

An almost identical circuit is used in the IF AGC system, but whereas the RF AGC Stages are fed directly from the output of the 100kHz filter, the IF system is driven from the final 100kHz IF Amplifier TR26. The IF AGC Stages comprise TR30 (UC734B) as Amplifier, TR31 (2N4254) Emitter Follower and D34 (1S44) Rectifier. Delay is provided by R239/240, and the discharge time constant is decided by the setting of the SIGNAL MODE SWITCH (S10B). A fairly rapid discharge is available in the 'AM' and 'CW/SSB' positions (C309) but a "hang" characteristic is provided when set to 'SSB HIGH-STAB' due to introduction of the larger capacitor C308. The IF AGC line is available at the rear of the set to permit linking receivers correctly for diversity working.

#### The CW/SSB Detector & BFO (TR32 & TR33)

An n-channel dual-gate MOSFET (TR33 :: 40673) is used as a product detector for CW/SSB reception, signal input being applied to gate 1 and oscillator injection at gate 2. Output is taken from the drain load (R262) to the 'CW/SSB' and 'SSB HIGH-STAB' settings of S10A via a low-pass filter which removes the 100kHz components.

Oscillator injection for CW reception is always derived from the tunable BFO (TR32). SSB signals can be copied using either the tunable BFO or the high-stability 100kHz outlet available from the Master Oscillator Unit via TR13. The latter will normally be used for this mode, except when circumstances make it undesirable to utilise the 'hang' type AGC characteristic which obtains in the 'SSB HIGH-STAB' setting of the MODE SWITCH. In this case, the 'CW/SSB' position is employed with the 'BFO' set to mid-position to provide the required 100kHz signal.

It should be noted that USB/LSB switching is not available on Ranges 7, 9 & 10 when the receiver operates with conversion direct from signal frequency to the 100kHz IF. Additionally, selectivity of the front-end circuits is such that they, rather than the IF circuits set the maximum bandwidth available on these frequencies. SSB transmission in any event is uncommon below 300kHz so this restriction should cause no inconvenience under normal circumstances.

The tunable BFO has a range of  $\pm 5$ kHz, tuned by C310/C311 and employs an n-channel junction FET type UC734B. The circuit is very similar to that used for the Incremental Oscillator.

Selection of the BFO or MO carrier insertion is achieved by means of S10C which completes the +12V supply to either TR32 or TR13 as appropriate. The supply is removed from both stages with S10C at 'AM'. Leakage of 100kHz carrier signal through TR13 in its turned-off condition is prevented by including two diodes D35 and D36 (2 x 1S44) which are arranged as RF switches to complete the signal path correctly for the desired mode of operation.

With S10C at 'CW/SSB', D35 becomes forward-biased and passes the tunable BFO output from C314 to R252 and thence via C317 to gate 2 of the product detector. At the same time, D36 will be reverse-biased because of the voltage developed across R252. This effectively interrupts the signal path from coaxial interconnection "I".

Moving S10C to 'SSB HIGH-STAB' removes the +12V supply from D35, so causing the voltage across R252 to fall below the level at which D36 becomes forward-biased. Under this condition, D36 offers minimum opposition to the 100kHz carrier which passes unhindered to gate 2 of the detector.

## THE AUDIO SECTION

Two independent audio channels are provided in this Section of the receiver making use of a total of five transistors. Separate gain controls are available, RV7 (AF GAIN) feeding the high-level channel which provides output for the built-in monitor speaker, an external loudspeaker or telephones. A pre-set control (RV6 :: LINE LEVEL) controls output on the low-level channel which is intended primarily for connection to 600-ohm line circuits. Both audio channels are usable simultaneously, their gain controls being wired in parallel and fed from the selector of S10A.

### The High-level Audio Channel (TR36-TR38)

The line-up on this channel comprises TR36 (BC107B), TR37 (40309) and TR38 (2N3054). R/C coupling is used between the first two stages and transformer coupling to the output transistor TR38. This latter stage runs as a Class "A" amplifier, having its operating condition set by precise adjustment of RV8 when undergoing test.

The output transformer has a 3-ohm secondary which is wired to feed the internal monitor speaker via the panel switch S11. R299 reduces the output power to a suitable level for the miniature speaker employed. The 3-ohm secondary is also connected directly to the external loudspeaker connection (SK/C-9), the speaker circuit being completed through an auxiliary contact on the telephone socket in such a manner that the speaker circuit is interrupted when telephones are in use. This latter output is attenuated by the series resistor R300.

### The Low-Level Audio Channel (TR34/35)

This channel utilises a straightforward R/C coupled circuit employing two BC107B transistors. The output transformer is electrostatically screened and provides a centre-tapped 600-ohm output for direct connection to remote line circuits. Diode D37 serves as a rectifier to operate the built-in meter when checking line level (see Page 21).

## FREQUENCY-SHIFT KEYING STAGES

The FSK Unit employs three linear integrated circuits and two transistors. It is not fitted as standard but is available to special order. Circuit information is included here for the sake of completeness.

100kHz input for the FSK Stages is taken from the Emitter Follower TR27 via coaxial interconnections "U" and "W". IC8 (CA3012/V1) functions as a single-ended limiting amplifier, providing a clipped 100kHz output to drive the FSK Discriminator D38/39 (2 x 1S44). Mark/Space pulses appearing across R314/315 are DC-coupled to the Source Follower TR40 (UC734B) which maintains light loading on the Discriminator output.

The following stage is a PNP transistor (TR41 :: BCY34) which serves as a Driver Stage for IC9. Use of a PNP unit at this point is dictated by the fact that terminal 5 of IC9 must lie close to earth potential in the absence of signal input. RV13 provides a means of establishing this condition (corresponding to equal base currents in the two input emitter followers which form part of the IC). The pre-set adjustment accommodates transistor spread and a metering point is provided on the printed board.

The CA3002/V1 used in the IC9 position functions as a single-ended DC-coupled clipping amplifier. Its square-wave output is converted to a near-sine wave in the shaping filter R322/323/C362/363 to eliminate residual FM noise components before application to the final stage IC10. This is a further CA3002/V1 in which the amplifier proper again clips the keying waveform. The last stage in IC10 is an emitter follower which drives a mercury-wetted contact reed relay RLC/1 to control the teleprinter circuit. RV14 permits adjustment of the relay bias conditions to achieve correct keying of the 'printer'. Access for adjustment is provided at the rear of the set.

Pulse output is available from the Discriminator via R316 to the meter circuit to provide visual indication when tuning to FSK signals. Mark/Space reversal can be achieved by use of the USB/LSB switch (except on Ranges 7, 9 & 10).

## THE METER CIRCUITS

The built-in meter (50-0-50 uA) can be switched to read carrier or line level and is operated with centre-zero for use as an FSK tuning monitor. Selection of the desired mode of operation is by means of the METER SWITCH S12A/B.

S12A selects the appropriate control voltage from either (1) the IF AGC line when reading carrier level, (2) the meter rectifier D37 for line level, or (3) the FSK Discriminator D38/39. Control is applied to the gate of TR39 (UC734B) which has the meter in its drain circuit.

S12B modifies the drain load in each of the three positions, pre-set controls being introduced automatically for correct setting of the electrical meter zero. Initial operating conditions in the meter circuit are set by RV11 which is adjusted to position the meter needle coincident with '0' on the arbitrary 0-10 carrier level scale. (METER SWITCH at 'RF'.)

In this position, the drain load comprises R303 and R44, the latter being part of the drain circuit of the cascode RF Amplifier TR1/2. This arrangement extends control of the meter to the RF AGC line when taking extremely strong signals since the voltage change across R44 will tend to suppress the meter zero as signal level increases. The 'RF' position of S12B remains operative with the AGC turned off, calibration in this case being essentially linear voltage.

The drain load for TR39 in the 'AF' position of S12 is the pre-set potentiometer RV10 which is adjusted to zero the meter needle to '0' on the mW scale. A second potentiometer (RV12) is adjusted on test to calibrate the meter scale for accurate mW readings with the line output terminated in 600 ohms.

In the 'FSK' position, RV9 is adjusted to hold the meter at centre-zero in the absence of a signal, (i.e. voltage across meter is zero). Output from the FSK Discriminator will be zero at the correct tuning point when taking a keyed signal but will deflect the meter needle away from centre when incorrectly tuned. The direction of deflection will depend on the direction of mistuning.

### POWER SUPPLY SECTION

The receiver can be operated directly from any AC supply in the voltage ranges 100/125V and 200/250V (40-60Hz), or from low-voltage DC supplies using an external DC/AC Converter.

Operating voltages are obtained from a high-grade potted transformer (T5) which has four separate secondary windings providing AC outputs of 18V @ 1A, 12V @ 0.1A, 12.6V @ 0.75A and 6V @ 0.6A. The 18V and 12V outputs are rectified by silicon bridge rectifiers D43 & D44 to provide independent positive and negative outputs. The positive supply feeds two zener diodes (D41 & D42) which regulate separate 12V and 15V supply lines. The negative output is regulated by D44 to provide a -6.2V supply rail. Resistance-capacity smoothing is employed on all three outputs.

The remaining secondary supplies are not rectified, the 12.6V output being used solely for the Master Oscillator oven, and the 6V line for all scale lamps except the 'HIGH-STAB' indicator. (This runs from the 12V DC line via a series dropping resistor). RV15 allows control of the intensity of the incremental and main scale markings to suit ambient lighting conditions. S3E switches off the incremental projection system when not required (Ranges 5-10) and also changes the MHz/kHz indicators when switching between Ranges 1-4 and Ranges 5-10.

Separate fuses are incorporated in the AC input (FS2) and the negative return from the main positive supply rectifier (FS1). C375, 376 and 377, together with CH33/34, provide protection against high voltage spikes riding on the mains input supply.

For Service Manuals Contact  
MAURITRON TECHNICAL SERVICES  
8 Cherry Tree Rd, Chinnor  
Oxon OX9 4QY  
Tel:- 01844-351694 Fax:- 01844-352554  
Email:- enquiries@mauritron.co.uk

MECHANICAL CONSTRUCTION

Dimensions

GENERAL

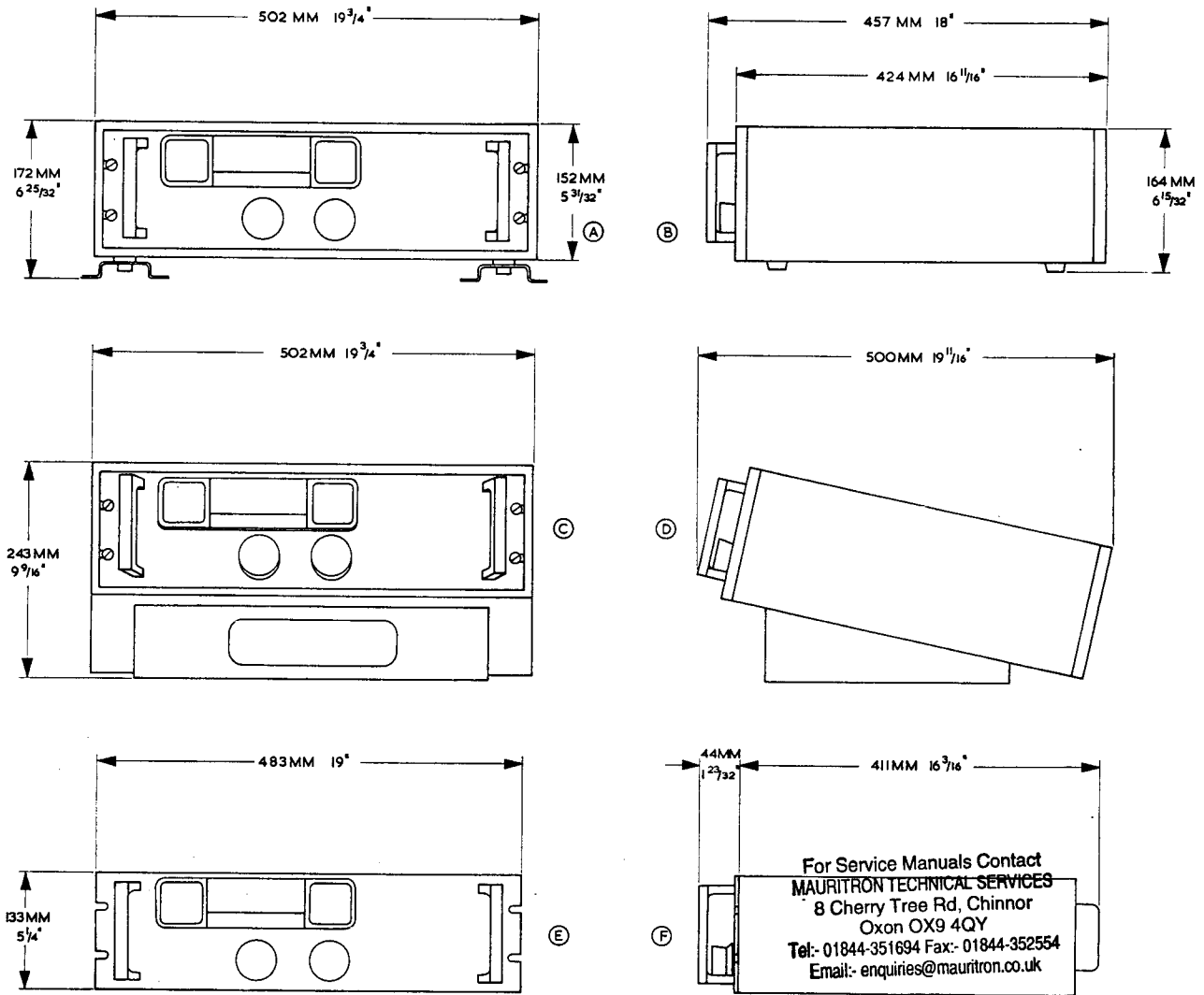

**Fig. 1** Dimensions of EC958 in all mounting styles.

- A Frontal dimensions of EC958 in Cabinet 8256/1P mounted on Shock-Absorbent Mountings LP2817/1.
- B Side elevation of EC958 in Cabinet 8256/1P fitted with standard mounting feet.
- C & D EC958 in Cabinet 8256/1P mounted on Plinth Speaker Cat. No. 989.
- E & F EC958 in standard rack-mounting form.

Weight

Bench-mounting receiver (complete with cabinet)	22.7kg.	50lb.
Ditto with Cat No. 989 OR LP2817/1	23.7kg.	52.25lb.
Rack-mounting version (with covers)	19.6kg.	43.5lb.

## Internal Layout

The receiver proper, (i.e. excluding cabinet) can be broken down into two main sub-assemblies which are independently attached to the front panel. Tie-points exist between the sub-assemblies to ensure complete rigidity when fully assembled.

The largest sub-assembly comprises three separate chassis plates, having flanges for direct attachment to each other and also to the receiver back-plate. The larger of the three plates is also fixed to the side-plate at the right-hand side of the receiver. This assembly carries the power supply section and all circuitry except the RF Unit and Incremental Oscillator. These two latter items are mounted on the rear of the dual tuning mechanism to form the other main sub-assembly. Additional anchorage is provided to the back-plate (l.h.s.), but construction is such that a side-plate of the type used on the right-hand side of the receiver is not required.

Alocrom-protected aluminium is used extensively in the construction of the receiver to keep overall weight to a minimum. The RF Unit is built on a rugged aluminium alloy die-casting which ensures an extremely high degree of mechanical stability in this vital section of the receiver. Heavy steel plates support the combined tuning mechanisms and the projection system used for the dial display. The front panel is a steel plate which contributes additional strength to the whole assembly. The cabinet is of rust-proofed steel and is equipped with fixing points for rubber feet, anti-vibration mountings and a plinth loudspeaker unit.

Most circuitry, apart from the power supply, is housed in detachable modules or units, almost all of which are mounted on the main chassis assembly. Reference to the plan view of the receiver will help the user become familiar with the positioning of the major units, while the text which follows will give a clear indication of the location of the various circuit components, transistors etc. Printed circuit techniques are employed almost exclusively.

## The RF Assembly

Comprises six separate printed boards together with six printed circuit turret disks which carry the full complement of inductors etc. in the turret proper. The boards are numbered 1-6 to assist location in Figs. 2 & 3. It should be noted that Circuit Board No. 2 is not mounted on the RF Assembly proper, but on the chassis immediately below it. Circuit Board No. 1 is attached to the side of the rear-most top cover adjacent to Circuit Board No. 3.

The six Turret Disks are identified by a letter code and run in sequence from the rear of the turret. Five contact positions are available on each contact block, but only four contacts are used on Disks "A", "B" and "C".

### RF ASSEMBLY :: CIRCUIT BOARDS

NB Circuit Board No. 7 is included in this list purely for convenience. It does not form part of the RF Assembly, but is the only other board in the whole receiver which is not part of a major assembly. Board No. 7 is mounted on the right-hand side-plate and in addition to the metering circuits also carries RV2 and RV4.

Board No.	Designation	Semiconductors	Resistors	Capacitors	Inductors
1	Crystal Calibrator	IC1	R1-4	C1	-
2	Peak-RF	D5-10	R30-36	C20-24	-

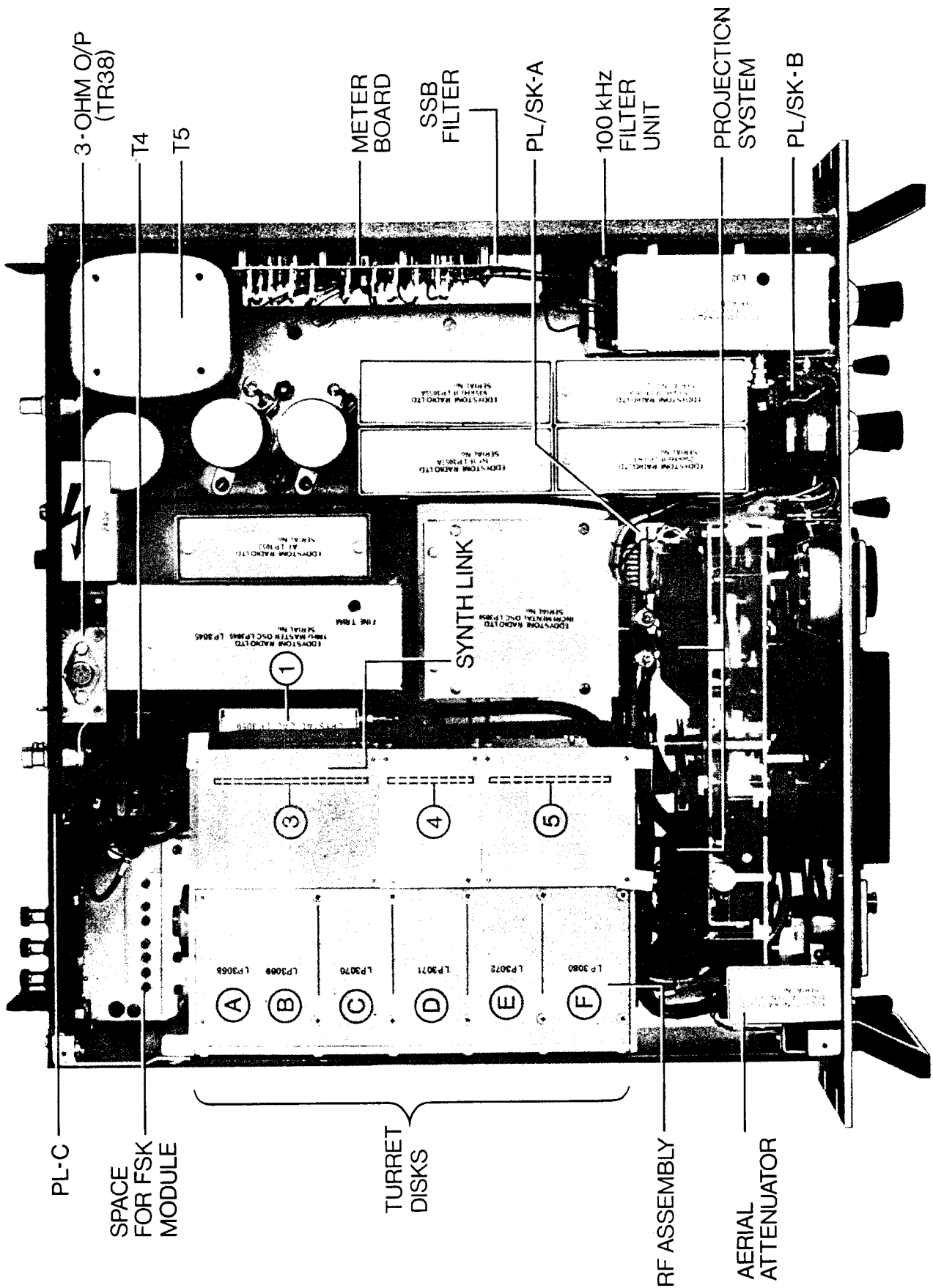

Fig. 2. Plan View of EC958 Receiver.

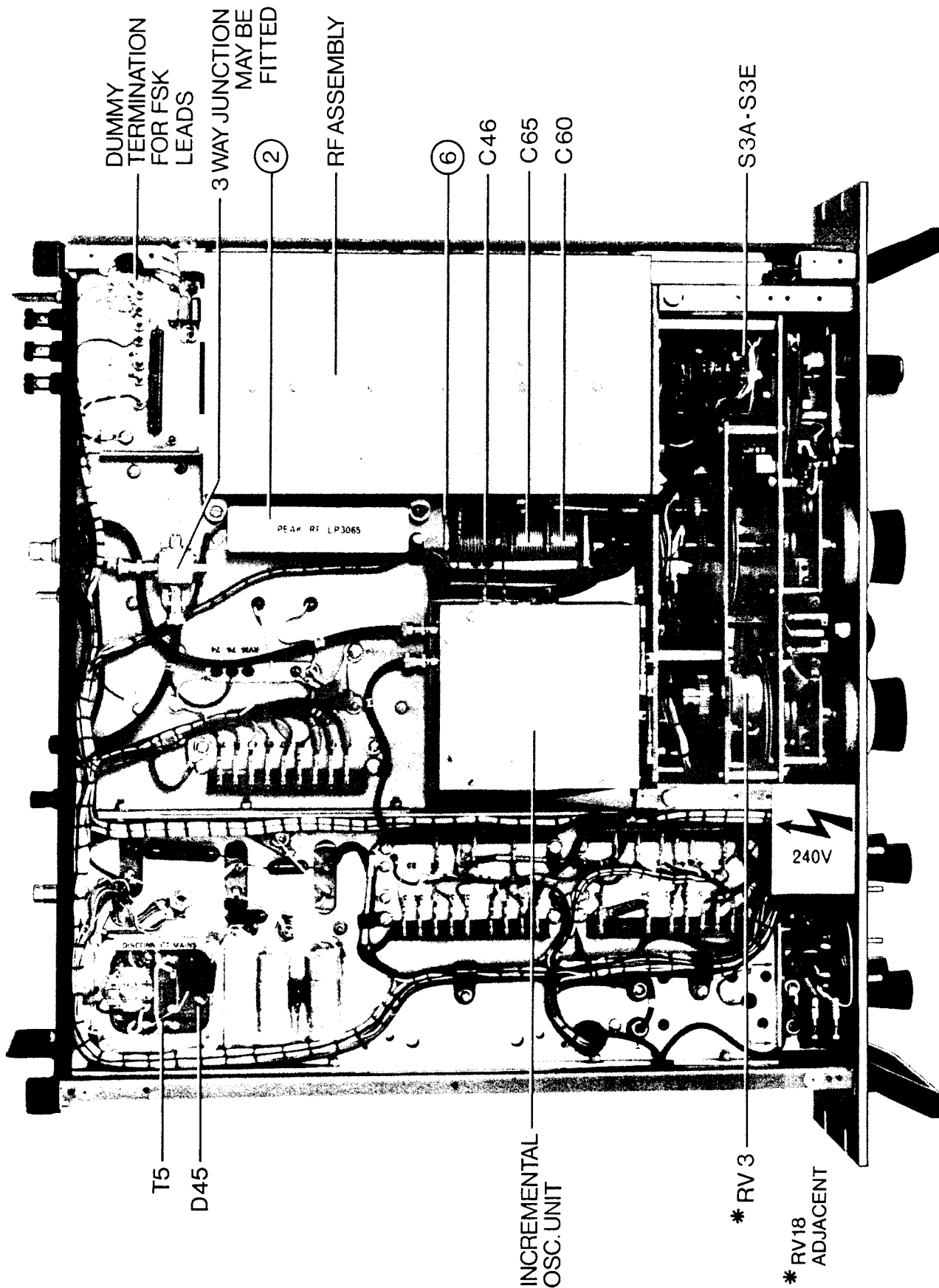

Fig. 3. Underside View of EC958 Receiver.

Board No.	Designation	Semiconductors	Resistors	Capacitors	Inductors
3	RF Amp.	TR1-3	R40-50	C32-43 excluding C37	CH1
4	Main-Tune Oscillator	TR4-5, IC2, D12	R55-60	C44-59 excluding C45- 46 & C48-49	CH2-3
5	Harmonic Amp.	TR6-7	R61-70	C62-74 excluding C65-66	CH4, L1
6	Main-Tune Osc. AFC	D11	R53-54	C48-49	-
7	Meter	TR39	R301-306 excluding R303. RV2, RV4 & RV9-12.	C349	-

RF ASSEMBLY :: TURRET DISKS

Disk Ref	Designation	Inductors	Capacitors	Resistors
"A"	Aerial Disk	L36-43	C380-393	R350-351
"B"	RF Disk	L44-53	C400-412	R360-361
"C"	Signal Mixer Disk	L54-63	C420-438	R370-377
"D"	Main-Tune Oscillator Disk	L64-73	C450-476	-
"E"	Loop Mixer Disk	L74-77	C480-487	-
"F"	Harmonic Amplifier Disk	L78-81	C490-497	R380

Modules and Units

Six standard-size modules, together with five other units of various dimensions, make up the remainder of the receiver. Their positions are shown in Fig. 2, and main component distribution is listed in the Tables which follow.

MAIN ASSEMBLY :: MODULES

Module No.	Designation	Semiconductors	Inductors etc.	Capacitors	Resistors
1	935kHz Loop Amplifier	TR8-11, IC3-5, D13-15 & 15A.	L2-9, CH5-8 RLB/1	C80-108	R80-95
2	Tunable IF	TR15 & IC12, D19-24A	L10-15	C140-168(1)	R120-138 (2)
3	250kHz IF	TR20-22, IC7, D27-29	CH15-CH17 CH15A & CH17A	C190-216(3)	R160-178 (4)
4	100kHz IF Amplifier	TR23-31, D32-34	L29-31, CH18-27	C260-300	R200-244 excluding R224
5	Audio Amplifiers	TR34-37, D37 <u>NB</u> TR38 is mounted separately on sub-chassis attached to back-plate.	T2, T3	C330-347	R270-294
6	FSK (Optional)	TR40-41, IC8-10, D38-40	L33, L34, CH32, RLC/1	C350-365	R310-326 RV13, RV14

- (1) Excluding C147, 150, 164 & 167.  
 (2) Including R120A & 134A, excluding R131-133.  
 (3) Including C206A, excluding C200, 201, 211 & 215.  
 (4) Including R164A, 167A, 168A, 170A, 171A & 172A.

For Service Manuals Contact  
**MAURITRON TECHNICAL SERVICES**  
 8 Cherry Tree Rd, Chinnor  
 Oxon OX9 4QY  
 Tel: 01844-351694 Fax: 01844-352554  
 Email: enquiries@mauritron.co.uk

MAIN ASSEMBLY :: UNITS

Unit No.	Designation	Semiconductors	Inductors etc.	Capacitors	Resistors
1	Aerial Attenuator	PC1 (8 diodes)	T1, RLA/1	C10	R11-16
2	Master Oscillator	TR12-14, IC6, D16-18	L35, CH9-13	C110-132	R100-114, RV16
3	Incremental Oscillator	TR17-19, D25, D26, D46	L16-18, CH35	C170-189	R140-155
4	100kHz IF Filter	<u>NB</u> SSB Filter is separate from main filter.	L24-28, CH36	C217-259 excluding C219	R180-190 excluding R187
5	CW/SSB Det & BFO	TR32, TR33, D35, D36	L32, CH28-31	C310-324	R250-263

## Access for Servicing

The basic constructional practice used in the EC958 Receiver is such that direct access is available for all minor servicing, plus easy breakdown of the complete assembly in the event of major servicing becoming necessary. Modular and unitised construction makes for ease of servicing by substitution and simplifies spares holding for establishments using a number of receivers of the same type. Extensive use of miniature coaxial inter-connectors, together with simple pin and socket connectors for unscreened wiring, facilitates removal of the various sub-units without need for use of a soldering iron. Multi-way connectors are used for connection between the main chassis and panel controls.

## THE TUNING DRIVES AND SCALE DISPLAY

Two identical geared mechanisms are employed for the main tuning and incremental controls. Reduction ratios are of the order 100:1, the drives being flywheel-loaded to permit rapid change in frequency setting. Backlash is almost totally non-existent, and re-setting accuracy of a very high order.

Drive output for the main tuning capacitors is taken via a linearising arm which is arranged to reduce the speed of gang travel at the high frequency end of the tuning sweep. The calibration display is not retarded in this way and a more linear tuning rate is therefore achieved.

Scale presentation is by means of a light-projection system in which a beam of light is projected through transparent markings on an otherwise opaque calibration disk. Both main and incremental displays employ the same technique, except that in the case of the main display, the position of the light-source is changed automatically as the appropriate range is selected. After passing through the disk, the light is transmitted through a twin-lens magnifier and falls upon a translucent screen. A polaroid filter and hooded escutcheon ensure a clear display when the receiver is used in conditions of high ambient lighting.

The calibration marks and figures are arranged in such a manner that there can be no confusion in reading frequencies from the limited portion of the individual range calibration visible at any setting of either control. Illuminated legends are included in the display to indicate whether the calibration figures are in MHz or kHz, and a further legend gives positive indication that the receiver is operating in its high-stability mode. The incremental scale is extinguished when using Ranges 5-10.

For Service Manuals Contact  
MAURITRON TECHNICAL SERVICES  
8 Cherry Tree Rd, Chinnor  
Oxon OX9 4QY  
Tel:- 01844-351694 Fax:- 01844-352554  
Email:- enquiries@mauritron.co.uk

REVERSE BLANK

## INSTALLATION

### GENERAL

#### CONTENTS OF ACCESSORIES KIT SUPPLIED WITH RECEIVER

Qty	Description	Part No.
4	*Cabinet Mounting Feet (complete with 4 x 2BA screws)	7132P
4	BNC bayonet-lock coaxial plugs (for Aerial Input etc.)	8012P
1	AC Supply Connector (complete with three-core cable)	D2311/1
1	Ancillaries Connector (15-way - complete with cover - pins 2 & 3 linked)	7771P
1	Telephone Plug	6567P
1	Test Lead (with male connector)	D4146
1	Test Lead (with female connector)	D4147
1	Allen Key (to fit control knob screws)	8449P
1	Screwdriver	7612P
1	Disk Insertion Tool	7857P
1	Trimming Tool (Neosid T.T.1.)	8451P
2	Spare Bulbs - 6V 60mA LEGEND LAMPS	6659P
4	**Spare Bulbs - 6V 0.2A PROJECTION LAMPS	8542P
4	Spare Fuses - 2 @ 1 Amp miniature glass cartridge 2 @ 2 Amp miniature glass cartridge	7173P 6704P
<p><u>NOTE:</u> Receivers dispatched adjusted for 100/125V working are supplied with 4 x 2 Amp fuses.</p> <p>(*) Not supplied with rack-mounting receiver</p> <p>(**) Two additional bulbs are retained in clip on Incremental Light Unit within receiver.</p>		

#### LIST OF ADDITIONAL ACCESSORIES AVAILABLE TO ORDER

Description	Part No.
Shock-absorbent Mounting Kit (supplied unassembled)	LP2817/1
Plinth Loudspeaker Unit	Cat. 989
Cabinet Loudspeaker Unit	Cat. 935
Telephone Headset	LP3242
Telephone Headset	LP3301
FSK Module (for use with standard EC958 only, not EC958/1)	LP3058
DC/AC Converter Unit (12V INPUT)	978/12
DC/AC Converter Unit (24V INPUT)	978/24
Standard Receiver Cabinet (for converting rack-mounting receiver to bench-mounting style)	8256/1P
Dust Cover - Top (for use when converting cabinet receiver to rack-mounting style)	8408/1PB
Dust Cover - Bottom	8408PC
Spares Kit (list of selected items on request)	-

## A S S E M B L Y   I N S T R U C T I O N S

### Mounting Style

EC958 Receivers are available for bench-mounting or rack-mounting, the latter being designated EC958/RM, EC958/1/RM etc. Receivers supplied w/ RM specification are fitted with protective dust covers which are absent on versions in cabinet style for bench-mounted installations. Receivers can be easily converted from one form of mounting to the other, accessories for this purpose being listed on the previous page.

**NOTE:** DUST COVERS MUST BE REMOVED WHEN FITTING A BASIC EC958/RM RECEIVER INTO THE STANDARD CABINET.

### Rack-mounting Receivers

Rack-mounting versions of the EC958 can be installed directly in 483mm (19in) racks, using four  $\frac{1}{4}$ in. BSF chromium-plated screws Eddystone Ref. 40A-330. Plain washers Ref. 27E-57 should be used to prevent damage to the panel finish. Fixing slots conform to standard with centre-spacing of 57.2mm (2.25in).

### Bench-mounting Receivers

Eight hank-bushes are provided in the underside of the cabinets used on standard bench-mounting receivers. These provide fixing points for (1) normal mounting feet, (2) Plinth Loudspeaker Unit Cat. No. 989, and (3) Anti-vibration Mounting Type LP2817/1.

The mounting feet should be attached using the four 2BA screws supplied, the correct fixing points being those nearest to the corners of the cabinet. These hank-bushes are also used when fitting the Anti-vibration Mountings, whereas the Plinth Loudspeaker Unit is screwed to the inner group of fixing points.

### Instructions for fitting Anti-vibration Mountings LP2817/1

1. Invert receiver.
2. Place the large neoprene washers over the fixing holes provided in the underside of the cabinet with stepped face uppermost.
3. Lower the channel-shaped mountings onto the washers, keeping the fixing flanges towards the outside of the receiver, and at the same time making sure that the step on the washers locates with the holes in the mountings.
4. Place the smaller neoprene washers on the inside of the channel-shaped pieces and pass the 2BA screws (with brass washers) through both neoprene washers.
5. Attach channel-shaped mountings to bench top with suitable screws: mountings should be bonded to bench if this is of metal construction.

## M A I N S   V O L T A G E   A D J U S T M E N T

**Transformer Input Tappings:** Unless otherwise specified at the time of ordering, receivers are dispatched from the factory with transformer taps set for 240V operation. Receivers set to other voltages are identified by a label attached to the rear which indicates the voltage to be used. Three voltage tappings are provided as follows:-

240V : for 230/250V.    220V : for 200/230V.    110V : for 100/125V.

Location of the appropriate tapping can be determined from the legend printed on the transparent cover fitted to the underside of the transformer. A soldering iron is required and care should be taken to transfer C375 (0.005 $\mu$ F) to the new tap connection.

## EXTERNAL CONNECTIONS

### Mains Input

A polarised connector (Eddystone Type D2311/1) fitted with six-feet of three-core cable is supplied with the receiver. The lead is colour-coded as follows :-

LIVE            ::     BROWN  
NEUTRAL        ::     LIGHT BLUE  
EARTH           ::     GREEN AND YELLOW

One end of the three-core lead is left free so that the user can fit a plug of a type suited to the installation.

### Aerial Inputs

Two separate aerial inputs are provided :-

1. Low-Z input   :: nominally 75-ohms unbalanced and usable at all frequencies 10kHz - 30MHz
2. High-Z input  :: nominally 600-ohms balanced for use only at frequencies below 1.6MHz.

Connections are to a BNC bayonet-lock coaxial socket for Low-Z inputs and to spring-loaded terminals for High-Z inputs. The latter can be unbalanced by fitting a shorting strap between the right-hand terminal and the adjacent earth terminal.

### IF Output

Provides a low-level, low-impedance output at the final intermediate frequency (100kHz) for driving external ancillaries (Model EP961 Panoramic Display Unit etc). An output of 20mV in 75-ohms is available for 3uV carrier at aerial input. Bandwidth is determined by the setting of the SELECTIVITY SWITCH and is adjustable to a maximum of 8kHz (except on lowest signal frequencies where bandwidth is restricted by the front-end tuned circuits).

A BNC bayonet-lock coaxial connector is provided for connection to this output.

### Telephones

The telephone output is suitable for use with low-impedance type headsets. Circuit arrangements provide for automatic muting of the external loudspeaker on insertion of the telephone plug. A suitable plug (Eddystone 6567P) is supplied with the receiver. The internal loudspeaker can be switched separately by means of a panel switch.

### Earth Terminal

Located below Mains Input connector. Bond to frame of rack when receiver is installed as a rack-mounted equipment; otherwise connect directly to supply earth. A separate "RF" earth can be connected to the terminal adjacent to the High-Z Aerial Input terminals.

### External Oscillator Drive

Two separate coaxial sockets are provided to permit external oscillator drive to be applied to the 1st and 2nd Signal Mixer Stages. Reference should be made to the paragraphs dealing with Diversity Working and Synthesised Operation which appear on pages 36 and 37.

### Ancillaries Connector (PL/C)

This is a miniature 15-way (male) connector mounted on the back-plate and providing connections for the following external ancillary circuits :-

1. External loudspeaker (3-ohms).
2. External lines (600-ohms or 150-ohms).
3. Teleprinter (polar or single-current keying).
4. Muting (internal relay controlled by external switching and supply).
5. AGC (for diversity working).
6. Remote Tuning.

Contact configuration and numbering on PL/C is indicated in Fig. 4 which also shows the internal receiver wiring associated with each connection, together with the external wiring to the free (female) connector SK/C which mates with PL/C. SK/C is viewed on the wiring side for convenience in terminating leads and also to facilitate comparison with the illustration of PL/C. Individual connections are dealt with below.

### External Loudspeaker

The EDDYSTONE Cat. No. 935 Cabinet Loudspeaker or the Cat. No. 989 Plinth Loudspeaker are recommended as being suitable for use with the EC958 Receiver, but any good 3-ohm unit can of course be used. Connection should be made to SK/C-1 and SK/C-9. Connection C-1 is earthed directly within the receiver. Note that the speaker circuit will be interrupted by an auxiliary contact on the telephone socket whenever a headset is used with the receiver.

### Line Output

The secondary winding of the line output transformer (T2) is wired to PL/C-13, PL/C-14 and PL/C-15. All connections are earth-free and electrostatically screened.

A 600-ohm line should be connected to SK/C-13 & SK/C-15; a 150-ohm line to SK/C-13 & SK/C-14. The transformer centre-tap connection (SK/C-14) can be earthed to provide a true balanced 600-ohm output or an unbalanced 150-ohm output. Earthing is achieved by linking SK/C-14 to SK/C-6 which is earthed directly within the receiver.

Refer to page 37 for details of interconnection of 600-ohm outputs in diversity working.

### Teleprinter Output

This facility is available only in receivers which carry the optional FSK Module Type LP3058.

Keying is by means of a high-speed mercury-wetted-contact reed relay with single-pole changeover circuit. The relay terminations are brought out at SK/C-10, SK/C-11 and SK/C-12. Line current monitoring and line rheostat should be provided externally in the normal manner.

Polar Working. Connect to SK/C-10, SK/C-11 & SK/C-12. Mark/space reversal is available by use of the USB/LSB SWITCH on all ranges except Ranges 7, 9 & 10. External switching must be arranged on these ranges as shown in Fig. 4.

Single-current Working. Connect to SK/C-11 and either SK/C-10 or SK/C-12 depending whether a make or break circuit is required. Either 80V line can be switched as required. Mark/space reversal must be arranged externally on Ranges 7, 9 & 10.

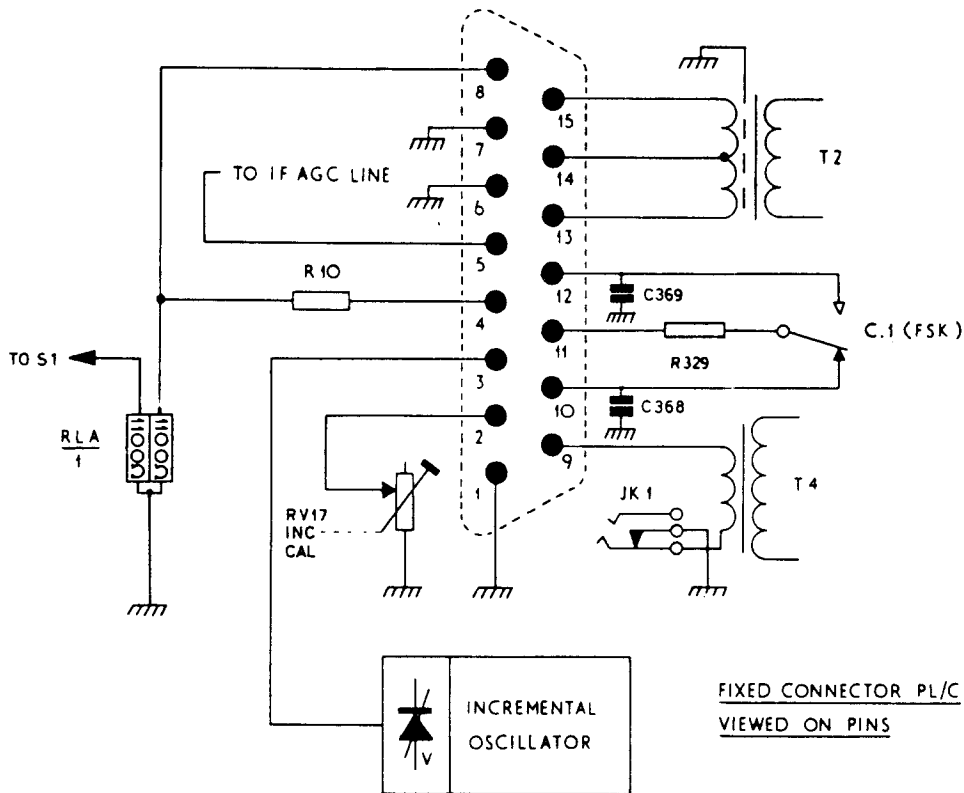

EXTERNAL EARTH CONNECTIONS  
CAN BE MADE TO EITHER SK/C-1  
SK/C-6 OR SK/C-7.

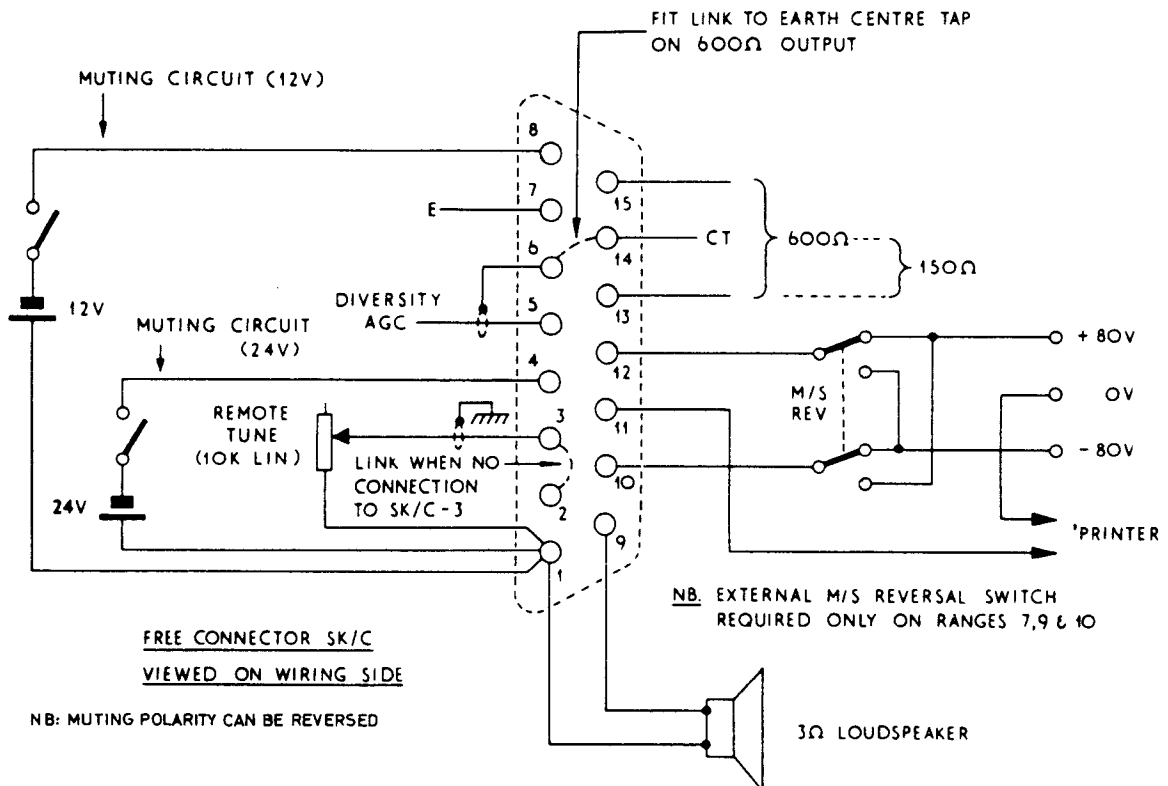

Fig. 4. Model EC958 :: Ancillary Connections (PL & SK/C)

## Muting

An internal high-speed reed relay is available if it is necessary to mute the receiver when used in close proximity to an associated transmitter. The relay has a single-pole changeover contact which is arranged to open the aerial input circuit, while at the same time grounding the input to the Aerial Attenuator.

One end of the relay coil is directly earthed within the receiver, external connection being via SK/C-1. The other end is brought out directly at SK/C-8, and also via a series resistor (R10), at SK/C-4. SK/C-8 is for 12V operation, SK/C-4 for 24V. The external supply should be connected via relay or manual switching as indicated in Fig. 4. The supply must be completed to energise the relay and mute the receiver. Current drain is of the order 10mA only. Supply polarity can be positive or negative w.r.t. earth.

## Diversity AGC

The IF AGC line is brought out at SK/C-5. Connection should be made with screened lead, the braid of which can be earthed at SK/C-6.

## Remote Tuning Facility (Ranges 1-4 only)

Provision is made for shifting the frequency of the Incremental Oscillator over a range of  $\pm 100$ Hz from a distant listening point. Control is achieved by means of a variable resistor (10,000-ohms, lin. law) wired between SK/C-3 and earth (SK/C-1). The resistor forms part of a potential divider which determines the reverse bias applied to the voltage-variable-capacitor D46 in the oscillator tuned circuit. A variation of the order 0-5V is available for the full travel of the 10,000-ohm variable resistor. Line resistance should not exceed 1,000-ohms.

SK/C-3 must be linked to SK/C-2 when the remote tuning facility is not required. This operation introduces RV17 to preserve a reverse bias at D46 equal to that provided by the external control when set to its mid-travel position. Calibration accuracy is thus maintained for normal working. SK/C-3 is linked to SK/C-2 on initial delivery of the receiver.

Screened cable should be used for connection to SK/C-3, the braid being earthed at either SK/C-1, SK/C-6 or SK/C-7 as convenient.

For Service Manuals Contact  
MAURITRON TECHNICAL SERVICES  
8 Cherry Tree Rd, Chinnor  
Oxon OX9 4QY  
Tel: 01844-351694 Fax: 01844-352554  
Email: enquiries@mauritron.co.uk

## DIVERSITY OPERATION

Two EC958 Receivers can be operated in diversity by linking their IF AGC lines and combining their audio output on the 600-ohm line channel. Separate aerials should be used in the normal manner.

AGC lines are commoned by linking SK/C-5 on both receivers, using a length of screened cable, the braid being earthed at the adjacent contact SK/C-6. Audio outputs can be combined as shown in Fig. 5, or alternatively by using a suitable outboard transformer having three separate 600-ohm windings.

Operation with common oscillator control is possible on Ranges 1-4 when the receiver is running in its high-stability mode. This arrangement leads to greater convenience in setting up the equipment and also simplifies remote tuning of the installation where this is required.

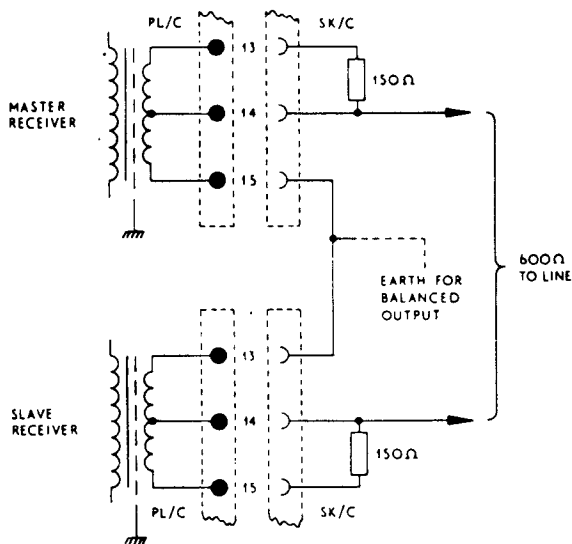

Fig. 5 Combined 600-ohm output wiring

The only accessory required for conversion to common oscillator working is a coaxial lead terminated at both ends with BNC bayonet-lock connectors. This is used to link the two coaxial sockets labelled '550-650kHz OSC IN/OUT' at the rear of the sets. One of the two Incremental Oscillators can be disabled by setting the NORMAL/SLAVE SWITCH (adjacent to coaxial output socket) to the 'SLAVE' position. This removes the supply voltage from all stages in the Incremental Oscillator Unit. The switch on the Master Receiver is left in the 'NORMAL' position to maintain the +12V supply to its Incremental Oscillator.

In operation, it must be remembered that the INCREMENTAL TUNING CONTROL on the Slave Receiver has to be set to the required frequency, not to tune the receiver in the normal sense, but to align the Tunable IF circuits to the appropriate intermediate frequency.

Diversity operation can also be arranged by operating the two receivers with their IF OUTPUT sockets linked together. Audio output can be taken from either receiver without the need for interconnection as in Fig. 5 above.

It should be noted that this method of connection is essential in the case of FSK Diversity working. Keying output can be taken from either receiver.

Reference should be made to the Section on 'Operation' for further information on diversity working.

#### SYNTHESISED OPERATION ON RANGES 5-10

Applications calling for high orders of stability at frequencies below 1.6MHz can be satisfied by using the EC958 Receiver in conjunction with an external synthesiser, oscillator drive being fed to the 1st Signal Mixer Stage via the lower of the two external oscillator drive sockets (labelled '1ST HF OSC INPUT'). Drive level should be of the order one volt from a low-impedance source, injection frequency being calculated as follows:-

Range 5	::	Signal frequency $\pm$ 250kHz
Ranges 6 & 8	::	Signal frequency + 250kHz
Ranges 7, 9 & 10	::	Signal frequency + 100kHz

A NORMAL/SYNTHESISED SWITCH is provided to allow the internal oscillator supply to be removed when using the synthesiser. The switch is adjacent to the input socket at the rear of the receiver.

Before installing a receiver for this type of service, it is first necessary to fit an internal link to complete the oscillator input cable to the injection point in the 1st Signal Mixer circuit. The linking points are located on the RF Amplifier printed board (Board No. 3), and are accessible after removal of the rear top cover on the RF Assembly. Refer to Fig. 2 for exact position of the link which is marked on the board with a broken line. The link should be removed when the receiver is returned to normal service.

For Service Manuals Contact  
 MAURITRON TECHNICAL SERVICES  
 8 Cherry Tree Rd, Chinnor  
 Oxon OX9 4QY  
 Tel:- 01844-351694 Fax:- 01844-352554  
 Email:- enquiries@mauritron.co.uk

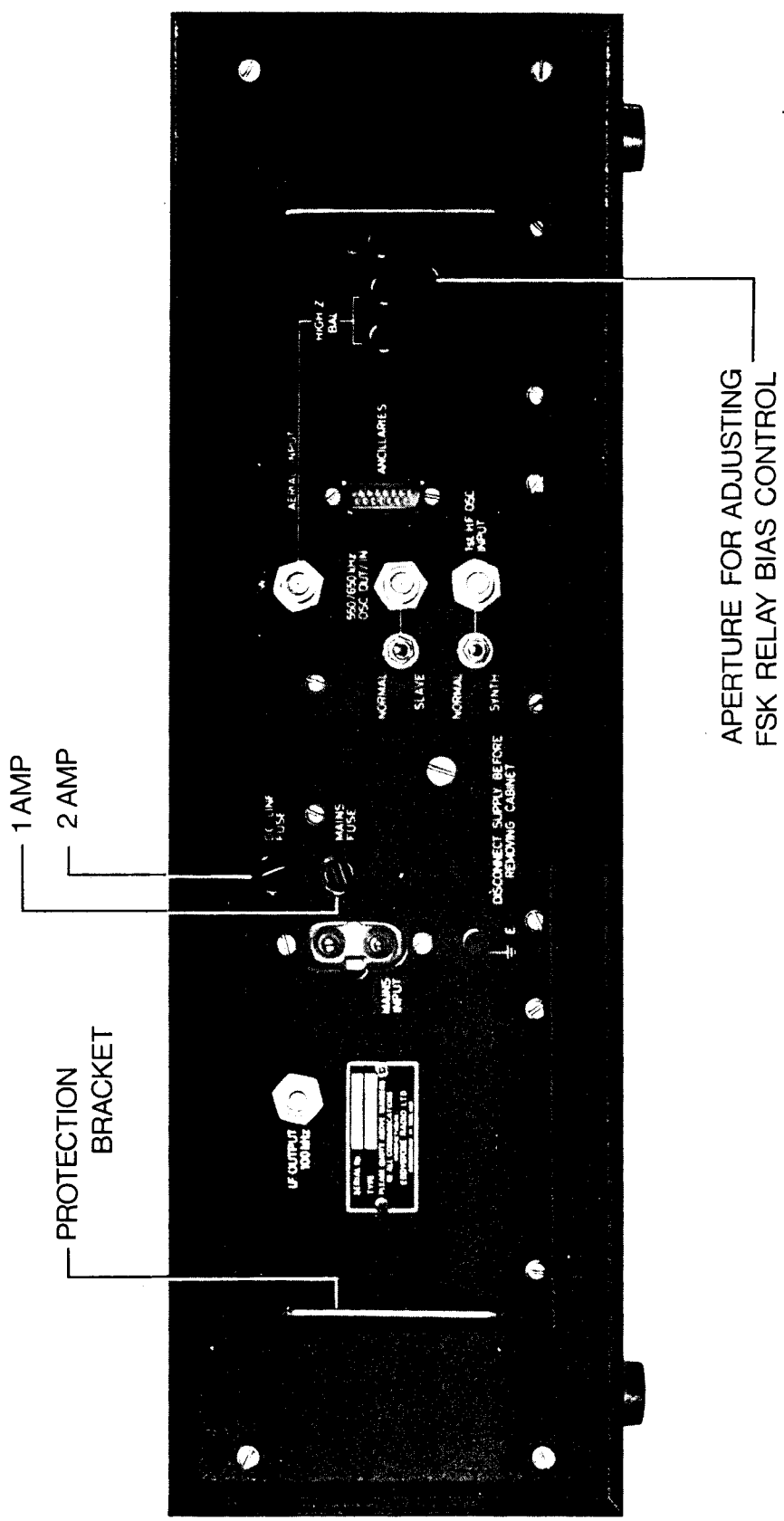

APERTURE FOR ADJUSTING  
 FSK RELAY BIAS CONTROL

Pages 39 & 40 do not appear in this handbook.  
 These pages are reserved for possible extension  
 of this Section.

Fig. 6. Rear View of EC958 Receiver showing external connections.

Incorporate opposite page 41 ('Operation' Section)

### Inoperative Controls - Ranges 5-10

Certain controls on the EC958 receiver are rendered inoperative when using it at frequencies below 1.6MHz (Ranges 5-10). The following Table indicates which controls are affected in this way and will assist operators during familiarisation on the equipment.

INCREMENTAL TUNING	Inoperative on all ranges below 1.6MHz due to receiver functioning as a single or double-conversion superhet.
HIGH STAB/ CONT TUNE SWITCH	Inoperative on all ranges below 1.6MHz. Continuous tune mode only is available in this band.
USB/LSB SWITCH	Inoperative on Ranges 7, 9 & 10 due to receiver functioning as a single-conversion superhet.
SELECTIVITY SWITCH	It is recommended that operators use only the 400Hz and possibly 1.3kHz positions when tuning on Ranges 9 & 10. If use of the 1.3kHz or wider band-width positions is demanded by operational requirements, the AF GAIN setting should be reduced to limit internally generated whistles resulting from the low signal frequencies involved.
CALIBRATOR SWITCH	Only one calibration marker is available below 1.6MHz, this appearing at 1MHz on Range 5.

The attention of all operators is also drawn to the following:-

#### AE TRIM/PEAK RF CONTROL

Functions as PEAK RF on Ranges 1-4 and AE TRIM on Ranges 5-10.

#### IF GAIN CONTROL

Rendered inoperative when MANUAL/AGC SWITCH is set to 'AGC' position.

#### NORMAL/SYNTH and NORMAL/SLAVE SWITCHES

These two controls are located at the rear of the receiver and must be set to 'NORMAL' except when receivers are used in diversity installations or with external synthesised oscillator drive. The receiver will be disabled under normal circumstances if the switches are set to 'SYNTH' or 'SLAVE'. Refer to pages 38/39 for more detailed information.

#### 'INC CAL' CONTROL

A pre-set variable resistor is now fitted to permit correction for minor errors in incremental calibration caused by long-term ageing of the oscillator components. The control is marked 'INC CAL' and is accessible through a small hole in the panel. A screwdriver is required for adjustment following the procedure detailed below:-

1. Set INCREMENTAL to 'Ø', SELECTIVITY to '3kHz', MODE to 'SSB HIGH-STAB'.
2. Select appropriate range and tune with MAIN TUNING CONTROL to any convenient frequency standard transmission (2.5, 5, 10, 15 or 20MHz - MSF, WWV etc.).
3. Switch to 'HIGH-STAB OPERATE' and check that the HIGH-STAB INDICATOR becomes illuminated.
4. Adjust INC CAL control for zero-beat.

If a suitable frequency standard transmission is not available due to propagation conditions, INC CAL can be set by monitoring the output from the oscillator on a frequency counter connected to the 550-650kHz OSC IN/OUT socket at the rear of the set. Frequency should be 650.00kHz when the INCREMENTAL TUNING CONTROL is set to 'Ø'.

## OPERATION

### CONTROL FUNCTIONS

#### Range Switch

Ten-position selector driving turret disks, carrier for light-source in main scale projection system, and auxiliary switching to select the appropriate scale display and intermediate frequency for the range in use. The only calibration visible is that applicable to the range selected. Illuminated legends indicate whether the calibration is in MHz (Ranges 1-4) or kHz (Ranges 5-10). The incremental scale projection system is extinguished automatically when using Ranges 5-10. The control has a bar knob to allow easy range selection and has stops adjacent to Ranges 1 and 10.

#### Main Tuning

High-grade geared reduction drive (Ratio 100:1) driving the six-gang tuning capacitor and the calibration disk forming part of the main scale projection system. Tuning rate varies with the range selected, typical figures being 3kHz per rev. at 200kHz and 125kHz per rev. at 20MHz. The main tuning scale appears at the left-hand side of the dial aperture and is arranged to display only those frequencies adjacent to the channel to which the receiver is tuned. Calibration marks and frequencies are repeated at such intervals that there can be no ambiguity or confusion in reading the scale at any setting. Marking of the individual ranges is detailed in the Table below.

#### MAIN SCALE CALIBRATION MARKING

Range	Coverage	Calibration Interval	Frequency Interval
1	19.8 - 30.0MHz	100kHz	100kHz
2	9.8 - 20.1MHz	100kHz	100kHz
3	4.0 - 10.0MHz	50kHz	100kHz
4	1.6 - 4.1MHz	50kHz	50kHz
5	680 - 1650kHz	10kHz	20kHz
6	280 - 690kHz	5kHz	10kHz
7	125 - 285kHz	1kHz	5kHz
8	53 - 126kHz	1kHz	1kHz
9	24 - 55kHz	0.5kHz	1kHz
10	10 - 24.5kHz	0.5kHz	0.5kHz

It should be borne in mind that on Ranges 1-4, the receiver operates as a triple conversion superhet with a 1st IF that can be tuned over a range extending some 100kHz from its nominal frequency. When using the MAIN TUNING CONTROL alone therefore, it is essential that the INCREMENTAL TUNING CONTROL is set to '0', or otherwise the main scale calibration will be in error by the number of kHz indicated on the incremental scale. The incremental facility is inoperative on Ranges 5-10 and does not affect the main scale calibration on these ranges.

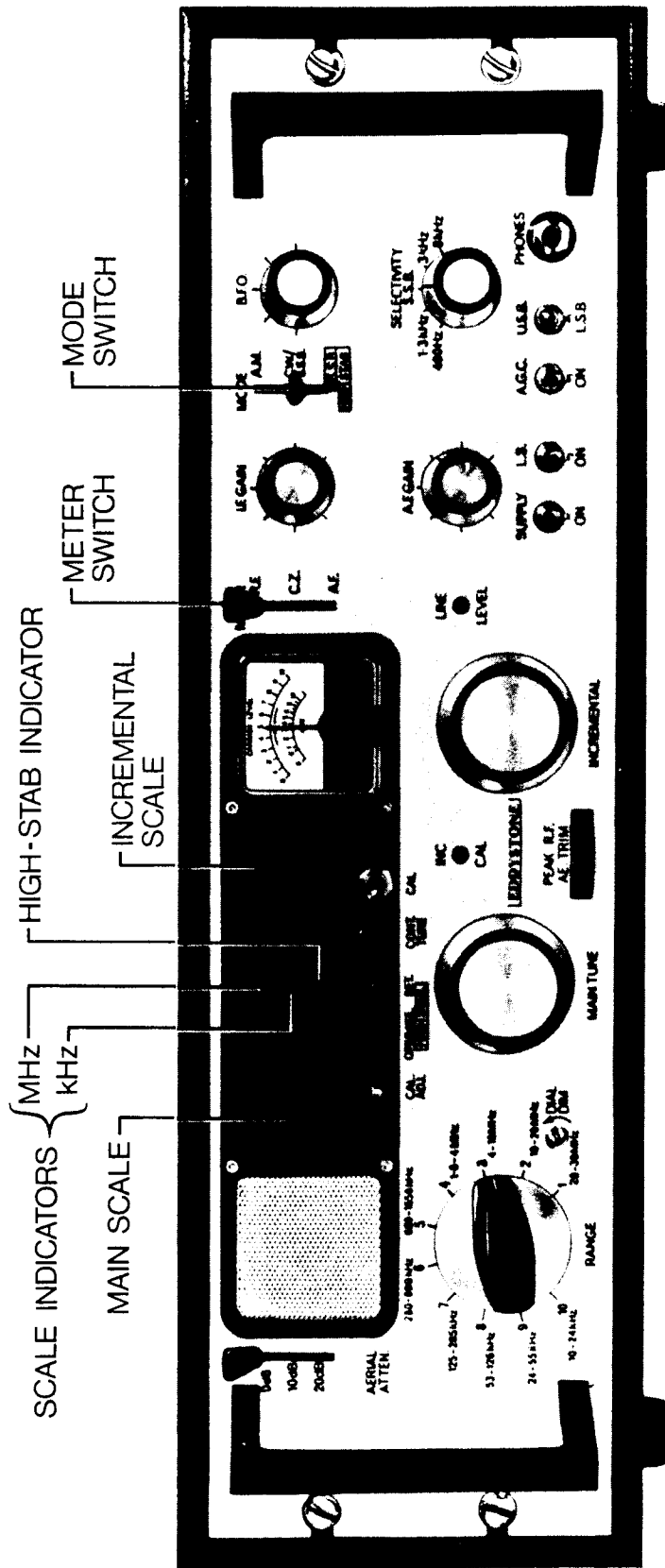

Fig. 7. Frontal View of EC958 Receiver showing controls.

For Service Manuals Contact  
**MAURITRON TECHNICAL SERVICES**  
 8 Cherry Tree Rd, Chinnor  
 Oxon OX9 4QY  
 Tel:- 01844-351694 Fax:- 01844-352554  
 Email:- enquiries@mauritron.co.uk

### Incremental Tuning

This control is operative only on Ranges 1-4 (1.6-30MHz) when the receiver operates with triple-conversion. It provides electrical bandwidth over a range of 100kHz at any frequency in this band and forms an essential part of the system employed for high-stability working. Tuning rate is sensibly constant (2.5kHz/Rev. at mid-band) with calibration figures at each 1kHz point and marks at 200Hz intervals. The scale display is interlocked with the range switching and disappears when Ranges 5-10 are selected.

In operation, the incremental reading must be added to the tune frequency shown on the main scale display, except when the incremental presentation changes and appears against an illuminated background (i.e. with black figures). This occurs on one side of the '0' setting and calls for subtraction of the incremental reading. A coverage of 2kHz only is provided in this direction to serve as an overlap between adjacent 100kHz segments when using the receiver in its high-stability mode. A similar extension of the coverage is provided at the other end of the incremental range.

Although primarily intended for use in high-stability working only, the incremental facility will nevertheless be found useful when operating the receiver in its normal mode. In this case it will serve as a 'fine' tuning control and will help considerably for example in resolving SSB signals, especially at the higher frequencies.

The Incremental Oscillator runs continuously on all ranges in the interest of optimum stability. On Range 6 it may be possible to detect a weak carrier due to the oscillator fundamental (550-650kHz). If this should occur in normal operation, it is only necessary to off-set the INCREMENTAL TUNING CONTROL to clear any interference which may be caused.

### Aerial Trimmer/Peak-RF Control

Functions as a conventional aerial trimmer on Ranges 5-10, and as a Peak-RF control on Ranges 1-4. In the latter case, it provides independent tuning of all signal frequency circuits to allow compensation for the inevitable misalignment which occurs when using the INCREMENTAL TUNING CONTROL. Change of control function is achieved automatically when switching between Ranges 4 and 5.

The control is a potentiometer which provides adjustable reverse-bias to a group of voltage-variable-capacitors included in the signal frequency circuits. It should always be set for maximum signal on completion of normal tuning adjustments, irrespective of the mode of operation or tuning range in use.

### Aerial Attenuator

This control takes the place of the more usual RF gain control and will usually be set to the 0dB position. The 10dB or 20dB settings can be used to reduce signal input level when cross modulation or blocking effects are noticed in the presence of extremely strong adjacent channel signals.

### High Stability/Continuous Tune Switch

Three-position lever switch mounted horizontally and located directly above the MAIN TUNING CONTROL. Panel marking is as follows :-

OPERATE	SET	CONT
		TUNE
<div style="border: 1px solid black; display: inline-block; padding: 2px;">HIGH-STAB</div>		

This control is non-functional when using Ranges 5-10, receiver performance etc. being unaffected regardless of the position to which it is set. Operators should however, make a practice of setting this control to the 'CONT TUNE' position, to ensure that normal continuous tune facilities are maintained when selecting Ranges 1-4.

On these ranges, the receiver employs triple-conversion with an incremental tuning facility, and can be operated when required as a high-stability unit. In this mode of operation, tuning is carried out by first setting the MAIN TUNING CONTROL to the 0.1MHz point at the low frequency end of the 100kHz segment in which the required signal frequency falls, and then selecting the precise frequency by use of the INCREMENTAL TUNING CONTROL. Initial adjustment of the MAIN TUNING CONTROL is carried out with the HIGH-STAB/CONT TUNE SWITCH in the 'SET' position, positive indication of correct setting being by illumination of the legend 'HIGH-STAB' which will appear immediately below the incremental scale calibration. It should be noted that the INCREMENTAL TUNING CONTROL can be at any setting in its range when this adjustment is carried out.

The HIGH-STAB/CONT TUNE SWITCH is moved to the 'OPERATE' position before using the INCREMENTAL TUNING CONTROL to tune to the exact frequency required. (Selecting the 'OPERATE' position introduces an AFC system which holds the Main-Tune Oscillator on frequency, locked against one of the harmonics derived from the highly stable Master Oscillator.) The setting of the MAIN TUNING CONTROL should not be disturbed after shifting the HIGH-STAB/CONT TUNE SWITCH to the 'OPERATE' position.

### Selectivity Switch

Five positions of selectivity are provided as follows :-

'400Hz'	:: ::	<u>CW NARROW</u>	'3kHz'	:: ::	<u>AM NARROW</u>
'1.3kHz'	:: ::	<u>CW WIDE &amp; FSK</u>	'8kHz'	:: ::	<u>AM WIDE</u>
'SSB'	:: ::	<u>SSB</u>			

All bandwidths except 'SSB' are determined by a block L/C filter. At 'SSB' a multiple crystal filter is introduced, this having an asymmetrical response and providing the correct passband for normal speech signals. Unwanted sideband rejection is of the order -50dB. 400Hz and 1.3kHz positions only should be used on Ranges 9 and 10.

### Signal Mode Switch

Three-position lever switch marked as follows :- 'AM' - 'CW/SSB' - 'SSB HIGH-STAB'. Functions carried out by this control are listed below.

'AM'	:: ::	Selects output from diode AM detector and disables the tunable beat oscillator.
'CW/SSB'	:: ::	Selects output from the 'CW/SSB' Detector. Switches on the tunable beat oscillator. Applies +12V supply to FSK Module when fitted.
'SSB HIGH-STAB'	:: ::	Selects output from the CW/SSB Detector. Transfers +12V supply from tunable beat oscillator to the carrier insertion stage in Master Oscillator Unit. Introduces an extra capacitor on the IF AGC line to provide 'hang' type AGC characteristic not available in the 'CW/SSB' position.

### Sideband Selection Switch

Alters the local oscillator injection frequency at the 3rd Signal Mixer and so provides a means of selecting 'USB' or 'LSB' reception. The panel legend is correct for Ranges 1-4, but must be reversed on Ranges 5, 6 & 8. Sideband switching is not available on Ranges 7, 9 & 10 when this control is inoperative due to the receiver operating with single conversion. The control can also be used for mark/space reversal switching in FSK reception (except Ranges 7, 9 & 10). Changeover from one sideband to the other is instantaneous and re-tuning of the receiver is not required.

### BFO Control

Provides adjustment of pitch in CW reception and is set to centre (100kHz) for carrier insertion when receiving SSB signals. The beat oscillator is rendered inoperative when the SIGNAL MODE SWITCH is set to 'SSB HIGH-STAB'.

A tuning range of  $\pm$  5kHz is available and the control has a slow-motion drive for greater ease of adjustment.

### IF Gain

Controls gain of the 100kHz IF strip when the MANUAL/AGC SWITCH is set to 'MANUAL'. Control is inoperative when set to 'AGC' in which case gain is at maximum in the absence of a received signal.

IF gain should be reduced as necessary to prevent detector overload when using manual control.

### AF Gain

Provides adjustment of audio gain on the speaker/telephone output only.

### Line Level

Pre-set control providing independent adjustment of audio gain on the line output channel only. The control can be adjusted with a small screwdriver and metering facilities are available to simplify adjustment when feeding output over a remote line circuit.

### Meter Switch

Three-position lever switch marked as follows:- 'RF' - 'CZ' - 'AF'. Functions carried out by this control are listed below.

'RF' :: :: Meter reads carrier level, the scale being calibrated in arbitrary steps 0-10 for relative measurement of signal strength. Meter indication is logarithmic at 'AGC' and linear at 'MANUAL'.

'CZ' :: :: Meter serves as centre-zero monitor to assist accurate tuning of FSK signals. This position is inoperative except when FSK Module is fitted. Meter will revert to centre-zero if 'CZ' is selected in a receiver without FSK facilities.

'AF' :: :: Meter serves as line output level indicator and is calibrated 0-10mW for 600-ohm line loading.

### \* Manual/AGC Switch

Two-position miniature toggle switch to select desired system of gain control in the IF section of receiver. The manual IF GAIN CONTROL is functional only when the MANUAL/AGC SWITCH is set to the 'MANUAL' position. Selecting 'AGC' takes the manual control out of circuit and causes the IF gain to rise to maximum in the absence of a received signal.

The RF AGC is continuously connected but becomes operative only on extremely strong signals.

Meter indication ('RF' position), changes from logarithmic to linear when the switch is moved from 'AGC' to 'MANUAL'. AGC discharge time constant is fixed, except when the SIGNAL MODE SWITCH is set to the 'SSB HIGH-STAB' position. In this case, the discharge time constant is increased to some 10 seconds to provide a 'hang' type AGC characteristic.

(\*) Panel legend reads AGC OFF/AGC ON,  
not MANUAL/AGC as implied in text. 45

For Service Manuals Contact  
MAURITRON TECHNICAL SERVICES  
8 Cherry Tree Rd, Chinnor  
Oxon OX9 4QY  
Tel:- 01844-351694 Fax:- 01844-352554  
Email:- enquiries@mauritron.co.uk

### Calibrator Switch

Push-button control which completes supply voltage to the internal Crystal Calibrator. Markers are available at 1MHz intervals throughout the entire range above 1MHz.

Calibration checks should be carried out with the SIGNAL MODE SWITCH in the 'SSB HIGH-STAB' position, and the SELECTIVITY SWITCH at 3kHz. The INCREMENTAL TUNING CONTROL must be at '0' and the MAIN TUNING CONTROL should be tuned for zero-beat with the marker signal. Interference from outside signals is reduced by automatic operation of the aerial relay when the CAL SWITCH is closed.

### Calibration Adjuster

Provides lateral movement of the cursor index line to permit correction for errors in main scale calibration. The index should be set coincident with the fixed centre line on those ranges where calibration facilities are not available.

### Speaker Switch

The miniature panel speaker is brought into use when this control is set to 'ON'. The external speaker circuit is muted separately by insertion of the telephone plug into the panel socket. Output to the external circuit falls very slightly when the internal speaker is in use.

### Dial Dimmer

Pre-set, screwdriver-adjusted control. Controls brilliancy of scale illumination and allows this to be set to suit ambient lighting conditions.

### Supply Switch

Completes both poles of the supply when set to 'ON'. Separate external switching must be arranged for the low voltage supply when using an external DC/AC converter.

### Relay Bias Control (see Fig. 4, Page 34)

This control forms part of the FSK Module and is therefore absent when this unit is not fitted. Access for adjustment is via an aperture in the back-plate just below the High-Z input terminals. The control is pre-set and is adjustable using a small screwdriver. Adjust for correct operation of teleprinter relay.

## TUNING INSTRUCTIONS

### Normal Operation

1. Put SUPPLY SWITCH to 'ON' and complete low-voltage supply to external DC/AC Converter if appropriate.
2. Switch on the panel loudspeaker, plug headset into telephone socket or use external loudspeaker as required.
3. Set the following controls as indicated :-

AERIAL ATTENUATOR	::	'0dB'
METER SWITCH	::	'RF'
HIGH-STAB/CONT TUNE	::	'CONT TUNE'
CAL ADJ	::	Mid-position
INCREMENTAL TUNING	::	'0' (R1-4 only)
DIAL DIMMER	::	As required
PEAK RF/AE TRIMMER	::	R1-4 Fully clockwise R5-10 Mid-travel

4. Select desired signal mode and appropriate selectivity.
5. Set BFO and/or USB/LSB SWITCH as required.
6. Adjust IF GAIN and AF GAIN for suitable output, selecting 'AGC' if required (IF GAIN is inoperative at 'AGC').
7. Select required range and tune to wanted frequency with MAIN TUNING CONTROL.
8. Check that PEAK-RF/AE TRIMMER is set for maximum signal.
9. Re-adjust IF GAIN and AF GAIN as necessary.
10. If using Ranges 1-4, carry out fine tuning on INCREMENTAL TUNING CONTROL, remembering that re-adjustment of PEAK-RF will be required for major tuning excursions, especially on Ranges 3 and 4.

#### Calibration Check

The Crystal Calibrator can be brought into operation to verify the scale accuracy when setting up for signal frequencies above 1MHz. Proceed as follows :-

1. Select 'SSB HIGH-STAB' and 3kHz selectivity.
2. Tune to the 'MHz' calibration point nearest to the required working frequency. Check that the INCREMENTAL TUNING CONTROL is set to '0' on Ranges 1-4.
3. Press CAL button and adjust MAIN TUNING CONTROL as necessary to locate marker signal. Tune to zero-beat.
4. Release CAL button and turn CAL ADJ to set scale index line coincident with the MHz marking.
5. Tune to required working frequency.

#### High Stability Operation on Ranges 1-4

1. Carry out operations 1-6 as for normal working.
2. Carry out calibration check at nearest 'MHz' point. NB This operation will not normally be required except when working at signal frequencies above 10MHz.
3. Move HIGH-STAB/CONT TUNE SWITCH to 'SET'.
4. Adjust MAIN TUNING CONTROL to 0.1MHz calibration point at the low frequency end of the 100kHz segment in which the required frequency lies. Tune about this setting and leave MAIN TUNING CONTROL in position where 'HIGH-STAB' legend becomes illuminated.
5. Move HIGH-STAB/CONT TUNE SWITCH to 'OPERATE' to introduce AFC system and so maintain Main-Tune Oscillator frequency.
6. Tune to required frequency using INCREMENTAL TUNING CONTROL. The incremental reading should be added to the main scale reading :-
 

e. g.	Wanted signal frequency	::	::	::	::	::	20.635MHz
	Set MAIN TUNING CONTROL to	::	::	::	::		20.6MHz
	Set INCREMENTAL TUNING CONTROL to	::	::				35kHz
7. Adjust PEAK-RF CONTROL for maximum signal.
8. For SSB reception, use 'SSB HIGH-STAB' setting of SIGNAL MODE SWITCH to derive carrier insertion frequency from Master Oscillator Unit.

9. Transfer HIGH-STAB/CONT TUNE SWITCH to 'CONT TUNE' when operation within selected 100kHz segment is no longer required. Revert to 'SET' position only if continued high-stability working is required in some other segment. The MAIN TUNING CONTROL should not be adjusted with the HIGH-STAB/CONT TUNE SWITCH at 'OPERATE'.

NB If operating the receiver in its 'CONT TUNE' mode for general search applications, and wishing to revert to 'HIGH-STAB' working while at the same time retaining the particular signal to which the receiver is tuned, operators should proceed as follows :-

Adjust MAIN TUNING CONTROL and INCREMENTAL TUNING CONTROL simultaneously in steps such that the required signal is held in tune and eventually occurs with the MAIN TUNING CONTROL set to the 0.1MHz point immediately below the wanted signal frequency. Then select 'HIGH-STAB', make any slight re-adjustment to the MAIN TUNING CONTROL to illuminate the 'HIGH-STAB' legend and finally tune accurately to the wanted signal with the INCREMENTAL TUNING CONTROL.

Alternatively, assuming the INCREMENTAL TUNING CONTROL to be set to '0', read the approximate frequency from the main scale, tune LF to the next 0.1MHz point, switch to 'HIGH-STAB' and then increase the incremental scale reading by the number of kHz required.

REFER TO ADDENDUM No. 1 FOR PROCEDURE EMPLOYED IN ADJUSTING INC CAL CONTROL TO COMPENSATE FOR LONG-TERM AGEING IN INCREMENTAL OSCILLATOR.

#### Diversity Working

Two EC958 Receivers running in diversity and wired as per the instructions given on page 38 should be tuned in the manner described below :-

NB It should be borne in mind that commoning the AGC lines results in the individual carrier level meters showing identical readings at all times. It is therefore necessary to disable one receiver while the other is tuned. To achieve this, the receiver to be disabled should have its MANUAL/AGC SWITCH set to 'MANUAL' and its IF GAIN reduced to minimum. Additional gain reduction can be introduced if required by setting the AERIAL ATTENUATOR to '20dB'. Both meters will continue to operate with identical readings as before, but will now be actuated only by the receiver which has not been disabled.

Ranges 5-10. The two receivers should be tuned individually to the required working frequency, disabling the Slave Receiver while tuning the Master Receiver and vice-versa. All functional controls should be adjusted to similar settings to suit the type of signal and conditions prevailing.

Each receiver must be disabled in turn when adjusting the LINE LEVEL CONTROLS since output on one channel will interfere with the meter reading on the other channel. In this case the meter common to the receiver being adjusted should be used as in normal operation.

Ranges 1-4. On these ranges, both receivers should be operated in the high-stability mode, preferably with common oscillator control.

Adjustment is similar to that employed on Ranges 5-10, except that only the receiver allocated as Master will control the exact tune frequency. The INCREMENTAL TUNING CONTROL on the Slave Receiver must be set to roughly the same setting as that of the Master Receiver in order that the Tunable IF circuits are correctly aligned at the required frequency. In common oscillator working, the NORMAL/SLAVE SWITCHES at the rear should be set as follows :- Master Rec. : NORMAL. Slave Rec. : SLAVE.

If common oscillator control is not employed, receivers should be tuned separately in the same manner as for Ranges 5-10, except that tuning will be by use of the two incremental controls after setting up for high-stability operation.

## FSK Operation

Receivers equipped with internal FSK Module provide direct keying connection for operation of a teleprinter. Normal tuning procedures apply with the addition of the following extra operations.

1. SIGNAL MODE SWITCH must be set to 'CW/SSB' position to apply +12V supply to the internal FSK Module.
2. METER SWITCH should be set to 'CZ', the receiver being tuned correctly when off-tuning causes the meter needle to swing away from centre position.
3. RELAY BIAS CONTROL (accessible at rear of set through aperture just below High-Z input terminals) should be set for correct operation of teleprinter relay.
4. USB/LSB SWITCH can be used for mark/space reversal when operating on any range except Ranges 7, 9 & 10. On these ranges this facility must be provided as an external control.
5. SELECTIVITY will normally be set to '1.3kHz', but '400Hz' position can be used when taking a signal with narrow shift.
6. BFO setting does not affect teleprinter operation because keying signal is derived directly from the 100kHz IF signal and not from audio output.

## METER ADJUSTMENT

There are four pre-set controls associated with the meter circuit. These are located on the right-hand side-plate and are accessible after removal of the cabinet. Their functions are as follows :-

RV9	..	..	FSK CZ SET.	RV11	..	..	RF ZERO SET.
RV10	..	..	AF ZERO SET.	RV12	..	..	AF CALIB.

Adjustment will be required at infrequent intervals only as detailed below :-

RV11 RF ZERO SET. This control must be adjusted before any of the others. Set METER SWITCH to 'RF', MANUAL/AGC SWITCH to 'MANUAL' and, with IF GAIN at minimum, adjust RV11 to set meter needle coincident with '0' on the arbitrary carrier level scale.

RV9 FSK CZ SET. Set METER SWITCH to 'CZ'. Adjust RV9 so that meter needle lies on red line at centre of meter scale (no-signal conditions).

RV10 AF ZERO SET. This control must be adjusted before RV12. Set METER SWITCH to 'AF' and with LINE LEVEL at minimum, adjust RV10 so that meter needle lies coincident with '0' on the 0-10mW scale.

RV12 AF CALIB. Adjust RV12 with METER SWITCH at 'AF' after adjusting RV10. Line o/p (PL/C-13 & PL/C-15) must be terminated in 600-ohms, either with a standard power o/p meter or a dummy load resistor. Signal for adjustment can be obtained by utilising the built-in Crystal Calibrator with BFO switched on and adjusted for beat of about 1kHz. With LINE LEVEL CONTROL at roughly 3/4 of maximum, adjust the IF GAIN until external meter registers an output of 10mW (2.45V on valve voltmeter patched across 600-ohm load). Adjust RV12 for reading of 10mW on panel meter.

REVERSE BLANK



## Projection Lamps

In the event of lamp failure, proceed as follows:-

1. Remove cabinet and place receiver in normal operating position to prevent dirt etc. falling into lens unit when lamp carrier is removed.
2. Set RANGE SWITCH to Range 1 position if failure is on main scale projection system (raises light unit to highest position for ease of access).
3. Pull lamp carrier out of light unit (friction fit).
4. Grip lamp holder tags with pliers and pull gently to remove lamp holder from carrier.
5. Unscrew faulty bulb from holder and fit replacement.
6. Check that bulb is free from finger grease and then push holder back into carrier (holder will click into position).
7. Slide carrier back into light unit.
8. Focus scale display by rotating lamp carrier and adjusting laterally as necessary.

Four spare bulbs are supplied with each receiver plus two in clips at the rear of the Incremental light unit. Bulbs are rated 6V @ 0.2A and carry Eddy-stone Part No. 8542P.

## FAULT DIAGNOSIS

Servicing techniques on a receiver of this type, although necessarily somewhat different from those adopted on older equipment of non-modular construction, do not deviate significantly from the well established procedures commonly employed in all advanced electronic workshops. Lack of immediate access to many supposedly vital components, though disturbing at first (even to highly skilled technicians), will be found not to present a serious obstruction to systematic servicing procedures. In fact, the many access points which are readily available for signal tracing etc., tend to simplify rather than complicate logical progression through the circuit. The service engineer should resist any temptation to carry out haphazard module/unit replacement in an effort to identify the area in which a fault lies.

Such an approach is totally unnecessary, for faults which may occur on the EC958 can usually be localised quite rapidly by observing whether performance is affected on all ranges or only on certain ranges. The Tables which follow are self-explanatory and will enable faults to be cleared quickly, even by engineers or technicians who may not be completely familiar with the equipment.

**NB** Two miniature coaxial connectors (one male, one female) are provided with the receiver, to permit connection to inter-module circuits. Each is supplied ready crimped to a suitable length of coaxial cable.

For Service Manuals Contact  
MAURITRON TECHNICAL SERVICES  
8 Cherry Tree Rd, Chinnor  
Oxon OX9 4QY  
Tel:- 01844-351694 Fax:- 01844-352554  
Email:- enquiries@mauritron.co.uk

## FAULT LOCATION TABLES

<u>RANGES OPERATIVE</u>	NONE
<u>RANGES NOT OPERATIVE</u>	ALL
<u>LIKELY FAULT AREA AND SUGGESTED TREATMENT</u>	
<u>POWER SUPPLY</u>	
Check availability of main supply voltages:-	
+15V :: Orange leads. +12V :: Red leads. -6V :: White leads.	<b>For Service Manuals Contact</b> <b>MAURITRON TECHNICAL SERVICES</b> 8 Cherry Tree Rd, Chinnor Oxon OX9 4QY Tel:- 01844-351694 Fax:- 01844-352554 Email:- enquiries@mauritron.co.uk
<u>AUDIO MODULE</u>	
Check availability of +15V supply at Module Pin 69. Check security of other module connections.	
<p><b>NB</b> There are two separate audio channels in this module, and it would be most unlikely that both would fail simultaneously. Thus, if monitor output is absent, check for output on Line Channel by setting METER SWITCH to 'AF' and, with IF GAIN and LINE LEVEL well advanced, tune over a known busy frequency band looking for fluctuation on meter. If meter does indicate presence of signals on Line Channel, fault could be in Audio Module, but may be in 3-ohm Output Stage (on rear plate). Investigate 3-ohm Output Stage before testing or replacing Audio Module. (See page 58).</p> <p>If meter shows no evidence of signals on Line Channel, fault is most likely in some other part of receiver (i. e. Audio Module <u>is</u> serviceable).</p>	
<u>100kHz IF AMPLIFIER MODULE</u>	
Check availability of +12V supply at Module Pin 53. Check voltage at Module Pin 48 (IF gain control line). Voltage should swing within the limits 0 - 4V for full traverse of IF GAIN (MANUAL/AGC SWITCH at 'MANUAL'). Check security of other module connections.	
Check whether IF output is available at IF Output socket on back plate. Check whether meter indicates presence of signals when METER SWITCH is at 'RF'.	
<p><b>NB</b> Internally generated signal for testing this module can be derived from the Master Oscillator Unit (100kHz carrier insertion output). Disconnect coaxial lead "I" at CW/SSB Detector and patch to coaxial lead "T" entering 100kHz IF Amp. Meter should indicate carrier when MODE SWITCH is set to 'SSB HIGH-STAB'. Sensitivity check can be carried out as detailed on page 58.</p>	
<u>100kHz IF FILTER</u>	
Check security of all coaxial connections.	
Check availability of +12V supply at Pin 56 (present on all ranges via PL/A-2 and PL/A-3).	

<u>RANGES OPERATIVE</u>	NONE
<u>RANGES INOPERATIVE</u>	ALL
(contd.)	
<u>RF ASSEMBLY</u>	
<p>Check availability of +15V supply at RF Amplifier Board (Termination No. 3).          Check availability of +12V supply at MTO Board (Termination No. 5).          If +12V supply is absent, check line continuity back to NORMAL/SYNTH SWITCH (S4 - lead 98) and then via lead 97 to Power Unit (Termination No. 128). S4 must be at 'NORMAL' position to complete circuit.</p> <p>Check whether receiver is operative from Tunable IF onwards. Select Ranges 1-4, connect aerial to coaxial lead 'J' (Tunable IF Input) via 100pF blocking capacitor. Tune INCREMENTAL TUNING CONTROL for medium-wave broadcast signals falling in the range 1235-1335kHz (RANGE SWITCH at 1, 2, 3 or 4).</p> <p>Check whether Main-Tune Oscillator is operative. Select Ranges 1-4, tuning in HIGH-STAB mode for normal illumination of HIGH-STAB INDICATOR at 100kHz points.</p> <p>If MTO is working, and all previous checks have indicated normal operation of the remaining stages, fault must be located in the RF or 1st Signal Mixer Stage (or associated wiring/switching). Tests can proceed using normal signal tracing technique and detailed voltage analysis. The Aerial Attenuator Unit should not be overlooked when a fault has been localised to the RF Section.</p>	

<u>RANGES OPERATIVE</u>	RANGES 7, 9 & 10
<u>RANGES INOPERATIVE</u>	RANGES 1-6 & 8
<u>LIKELY FAULT AREA AND SUGGESTED TREATMENT</u>	
<u>250kHz IF MODULE</u>	
<p>Check availability of +12V supply at Module Pin 38.          If absent, check line continuity via PL/A-4, S3D and PL/A-2 through to Power Unit (Termination 118).</p> <p>Check availability of -6V supply at Module Pins 42 and 44. (Voltage appears at 44 with USB/LSB SWITCH (S7) set to 'USB'. At 42 in 'LSB' position.)</p> <p>Check availability of -2.7V supply at Module Pin 41. (-6V line via R179)</p>	

RANGES OPERATIVE

RANGES 7, 9 & 10

RANGES INOPERATIVE

RANGES 1-6 & 8

(contd.)

If -6V and/or -2.7V supplies are absent, check line continuity from Power Supply (Termination No. 120) to S7 via PL/B-4, and through to Module Pins 41, 42 & 44 via PL/B-20, PL/B-18 & PL/B-19 respectively.

Check for possible s/c on coaxial leads "K" & "P".

Check 250kHz IF Module (see page 58).

RANGES OPERATIVE

RANGES 5-10

RANGES INOPERATIVE

RANGES 1-4 (At all settings of HIGH-STAB /  
CONT TUNE)

LIKELY FAULT AREA AND SUGGESTED TREATMENT

TUNABLE IF MODULE

Check availability of +15V supply at Module Pin 22.

If absent, check line continuity through to Power Unit (Termination No. 115).

Check for possible s/c or o/c on coaxial leads "J", "M", "N" & "P".

Check S3C. (Second wafer from rear of bank).

Check Tunable IF Module (see page 58).

**NB** If low gain only on Ranges 1-4, check voltage on control line to Module Pin 23 (VVC Tuning from RV3 via PL/A-14).

INCREMENTAL OSCILLATOR UNIT

Check availability of +12V supply at Unit Pin 19.

If absent, check line continuity via PL/A-6, S6 (set to 'NORMAL'), through to Power Unit (Termination No. 128).

Check for possible s/c or o/c on coaxial leads "N" & "O".

Check Incremental Oscillator output. Link 550-650kHz IN/OUT socket to AERIAL INPUT and tune oscillator range on MAIN TUNING (Range 6).

See page 59.

For Service Manuals Contact  
MAURITRON TECHNICAL SERVICES  
8 Cherry Tree Rd, Chinnor  
Oxon OX9 4QY  
Tel: 01844-351694 Fax: 01844-352554  
Email: enquiries@mauritron.co.uk

<u>RANGES OPERATIVE</u>	RANGES 5-10
<u>RANGES INOPERATIVE</u>	RANGES 1-4 (At 'CONT TUNE' only)
<u>LIKELY FAULT AREA AND SUGGESTED TREATMENT</u>	
<u>935kHz CRYSTAL OSCILLATOR (Part of 935kHz LOOP MODULE)</u>	
<p>Check availability of +12V supply at Module Pin 32.          If absent, check line continuity via PL/B-12, S5B (at 'CONT TUNE'), PL/B-11, PL/A-5, S3D (at Ranges 1-4), PL/A-2 through to Power Unit (Termination No. 118).</p> <p>Check availability of -6V supply to Module Pin 29.          If absent, check line continuity through to Power Unit (Termination No. 114).</p> <p>Check for possible s/c or o/c on coaxial lead "M".</p> <p>Check IC5 and associated circuitry within Loop Module.</p>	

<u>RANGES OPERATIVE</u>	RANGES 5-10
<u>RANGES INOPERATIVE</u>	RANGES 1-4 (At 'HIGH-STAB' only)
<u>LIKELY FAULT AREA AND SUGGESTED TREATMENT</u>	
<u>935kHz LOOP MODULE</u>	
<p>Check availability of +12V supply at Module Pin 28.          If absent, check line continuity via PL/B-9, S5B (at 'HIGH-STAB'), PL/B-11, PL/A-5, S3D (at Ranges 1-4), PL/A-2 through to Power Unit (Termination No. 118).</p> <p>Check for possible s/c or o/c on coaxial leads "H" &amp; "M".</p> <p>Check loop circuitry within 935kHz Loop Module (see page 59).</p>	
<u>MASTER OSCILLATOR UNIT</u>	
<p>Check availability of +12V supply at Unit Pin 77.          If absent, check line continuity through to Power Unit (No. 130).</p> <p>Check for possible s/c or o/c on coaxial lead "G" (double-screened lead).</p> <p>Check Master Oscillator Unit (see page 59).</p>	
<p><u>NB</u> Normal operation of Master Oscillator Unit is likely if 'SSB HIGH-STAB' is operative on all ranges.</p>	

RANGES OPERATIVE

RANGES 5-10

RANGES INOPERATIVE

RANGES 1-4 (At 'HIGH-STAB' only)

(contd.)

MTO AMPLIFIER, HARMONIC AMPLIFIER & 1ST LOOP MIXER (RF ASSEMBLY)

Check availability of +15V supply at Pin 7 (RF Assy.)

If absent, check line continuity via PL/B-8, S5A (at 'HIGH-STAB'), PL/B-2 and through to Power Unit (Termination No. 122).

Check availability of -6V supply at Pin 8 (RF Assy.)

If absent, check line continuity through to Power Unit (Termination No. 125).

Check for possible s/c or o/c on coaxial leads "G" or "H".

Carry out detailed voltage analysis on MTO Amp., Harmonic Amp. and 1st Loop Mixer.

For Service Manuals Contact  
 MAURITRON TECHNICAL SERVICES  
 8 Cherry Tree Rd, Chinnor  
 Oxon OX9 4QY  
 Tel: 01844-351694 Fax: 01844-352554  
 Email: enquiries@mauritron.co.uk

PERFORMANCE TESTINGOverall Performance

If substandard performance is suspected, the receiver should be withdrawn from service and subjected initially to an overall performance check at the mid-frequency in each of the ten frequency ranges. An accurately calibrated signal generator matched to 75-ohms should be employed, having a reliable attenuator and low signal leakage. Output readings can be taken using the integral receiver meter with the METER SWITCH at 'AF'. The line output terminations should be wired to a 600-ohm load (PL/C-13, PL/C-15).

Sensitivity readings should be taken for 10dB s/n ratio at 10mW output with the receiver controls set as indicated below. Further checks should be made at mid-band 100kHz points on Ranges 1-4 with receiver running in high-stability mode.

HIGH-STAB/CONT TUNE :: 'CONT TUNE'	AERIAL ATTENUATOR :: 0dB
INCREMENTAL TUNING :: '0' (R1-4)	METER SWITCH :: 'AF' (0-10mW)
MODE SWITCH :: 'AM'	AF GAIN :: As required for monitoring
SELECTIVITY SWITCH :: '3kHz'	IF GAIN* :: 3/4 of maximum setting
MANUAL/AGC SWITCH :: 'MANUAL'	LINE LEVEL :: Adjust for 10 mW

\*Use IF GAIN for fine adjustment of output level.

Sensitivity on all ranges should be equal to or better than 3uV for 10dB s/n ratio. In the event of sensitivity being lower than this figure on one or more ranges, but not on all ten (\*), investigation should be restricted to the RF Assembly, checking alignment and carrying out detailed voltage analysis. If sensitivity is generally low on ALL ranges, testing can proceed as detailed on the following page.

\*Excluding special cases of low gain on all except 7, 9 & 10, or all except 5-10.

## Audio Section

Repeat overall sensitivity check (on any range) for 10dB s/n, but using 3-ohm channel to determine whether fault lies in 600-ohm line channel. Test should be carried out with AF GAIN set for reading of 50mW on external Power Output Meter wired to PL/C-1 and PL/C-9 (meter matched to 3-ohms). If sensitivity is still found to be lower than normal, the fault does not lie in the Audio Module.

Direct audio sensitivity figures for the Audio Module alone, using 1000Hz test signal are as follows:-

### Monitor Channel (3-ohm)

Audio in at Module Pin 68 (existing lead disconnected) should show sensitivity of 20mV for 100mW output on external meter. (AF GAIN is inoperative)

### Line Channel (600-ohm)

Audio in at Module Pin 67 (existing lead disconnected) should show sensitivity of 15mV for 10mW output on panel meter. (LINE LEVEL is inoperative)

### 3-ohm Output Stage

This stage can be checked independently if a fault is suspected on the Monitor Channel. Connection is most easily made by disconnecting Pin 71 on the Audio Module. The audio generator is fed into the free lead which terminates at No. 91 on 3-ohm Output Stage.

An input of 400mV should produce 100mW on external meter connected to 3-ohm output.

## IF Sensitivity

IF sensitivity can be checked by introducing a modulated test signal (30% at 400Hz), at the signal gate of the 1st Signal Mixer (via C38 with lead to disk contact disconnected). The fundamental circuit configuration permits checking the 100kHz IF alone, the 100kHz and 250kHz IF's together, or all three IF channels simultaneously by setting the RANGE SWITCH to ranges employing single, double or triple conversion respectively. Appropriate ranges and test frequencies are as follows:-

<u>Range</u>	<u>IF's Operative</u>	<u>Test Frequency</u>	<u>Input for 10dB s/n at 10mW on Line Meter</u>
7	100kHz only	100kHz	20uV $\pm$ 6dB
5	100kHz and 250kHz	250kHz	15uV $\pm$ 6dB
4	100kHz, 250kHz and Tunable IF	1335kHz	less than 10uV

Control settings should be as for the overall performance check, but with the IF GAIN at maximum. 10mW output level should be set by use of LINE LEVEL control. The INCREMENTAL TUNING CONTROL must be set to '0' when carrying out the test on Range 4.

## Miscellaneous

The following additional performance figures are included here to assist service engineers carrying out more advanced fault-finding.

### CW/SSB Detector & BFO Unit

An unmodulated input of 30mV at 100kHz into coaxial socket "V" should produce an output of 10mW on the integral meter with LINE LEVEL set to maximum.

## Tunable IF Module

If low drive levels are suspected to the 2nd Loop Mixer via coaxial leads "M" or "N", substitute signals can be fed into the module from an external source. Drive levels necessary to produce normal operation (as determined by overall performance checks, or an IF sensitivity check on Range 4) are as follows:-

Coaxial lead "M"    ::    300mV at 935kHz.

Coaxial lead "N"    ::    550mV in the range 550-650kHz.\*

\*INCREMENTAL TUNING CONTROL must be adjusted to peak Tunable IF circuits to suit signal generator frequency. Remember that direction of tuning is reversed, i. e. "0" setting corresponds to highest intermediate frequency (1335kHz).

## Incremental Oscillator Unit

Level of output at 550/650kHz OSC IN/OUT socket (at rear) should lie in the range 300mV to 600mV. A substitute testing signal can be derived from a second EC958 if available.

## 935kHz Loop Module

Normal operation of the Loop Amplifier (IC3) can be verified by introducing an external unmodulated 935kHz signal via coaxial lead "H". The HIGH-STAB INDICATOR should light up when the input level exceeds 0.7mV.

An alternative check in the event of a fault existing in the legend lamp circuit, is to feed a 1mV 935kHz signal via coaxial lead "H", while monitoring the output on coaxial lead "M". An output of the order 300mV should be obtained.

AFC operation can be checked by offsetting the signal introduced via coaxial lead "H", and reading voltage at Module Pin 34 with a valve voltmeter. Readings should be of the order:-

935kHz	::	+8V
935kHz + 3kHz	::	+9V
935kHz - 3kHz	::	+7V

## Master Oscillator Unit

Output level measured on coaxial lead "I" using a valve voltmeter should be of the order 2.8V (MODE SWITCH set to 'SSB HIGH-STAB').

Output level measured on coaxial lead "G" should be of the order 3V p-p measured on an oscilloscope.

## FSK Module

Normal operation of the FSK Discriminator can be checked by introducing an unmodulated 100kHz signal via coaxial lead "W". Input level should be 15mV, and the voltage at Module Pin 81 will reach the following voltages for offsets of 850Hz:-

100kHz	::	0V
100kHz + 425Hz	::	+3.3V
100kHz - 425Hz	::	-3.3V

A valve voltmeter should be used for measurement of the voltage at Module Pin 81.

## RE - ALIGNMENT

### General

All Modules and Units employed in the EC958 are pre-aligned on factory test jigs before they are fitted to the main chassis assembly. Further adjustment of the module/unit circuits is not normally required. Replacement Modules and Units supplied for user-servicing are also pre-aligned in this way and can be installed without major adjustment. Instructions for carrying out any minor adjustments which may be required in some cases will be furnished with the replacement item.

Turret Disks are also treated in a similar manner, but are subjected to further minor adjustment after installation in the receiver. This initial in-situ factory alignment should hold for a long period of time, and re-alignment should only be contemplated if there is a clear indication that this course of action is in fact necessary.

This same procedure should be adopted in the event of Turret Disks being changed when fault-finding on receivers in operational service. Alignment should be restricted to the replacement disk(s), taking care to avoid excessive trimmer/core shifts in view of the very minor adjustment which will be required.

Re-alignment should be carried out only by skilled technicians having a sound knowledge of the procedures involved. High-grade test instruments should be employed. All pre-set adjustments - trimmers, cores etc. - are self-locking, and should not be sealed with wax or other similar compounds.

### Re-alignment of the RF Assembly (Coil Turret)

The paragraphs which follow, cover the entire alignment procedure applicable to the Turret Assembly. Relevant data can be extracted as necessary when re-alignment of specific disks only is required. Disks will have been pre-aligned before despatch, so major adjustments will not be necessary. Instructions for removal and replacement of disks will be found on page 66.

### Access to Trimming Adjustments

All trimming adjustments are accessible after removal of the long top cover plate which carries the disk identification (12 screws). Except in the case of Turret Disk "A", all trimmers and cores are adjacent to each other in pairs (one trimmer - one core), and are adjusted from the top of the turret with the trimming tool angled at approximately 60°. The correct coil and trimmer for the selected range are easily identifiable by their proximity to the contact blocks.

Coil positions on Turret Disk "A" are identical to those on the other disks, but the trimmers are adjusted through an access hole in the rear of the turret casting (close to bearing). The FSK Module should be removed when adjusting these trimmers, taking care to dress the free leads so that short-circuits cannot occur. It is preferable that the dummy termination plate be fitted temporarily for this purpose.

### Main-Tune Oscillator (Turret Disk "D")

Alignment should commence with adjustment of Turret Disk "D" (MTO). An accurate frequency standard must be available to provide marker signals throughout the entire coverage of the receiver (10kHz-30MHz). On the lower frequencies it will be found advantageous to utilise a standard signal generator, which itself can be standardised against the frequency standard employed. The latter should provide harmonic output at 10kHz and 100kHz points for greatest convenience in carrying out the necessary adjustments (the integral calibrator can be used to permit positive identification of the MHz settings). Marker signals should be introduced at the LOW-Z aerial input socket, with the receiver controls set as indicated at the top of the opposite page.

RANGE SWITCH )	::	See Table on Page 62 for alignment frequencies etc.
MAIN TUNING )		
INCREMENTAL TUNING	::	'0' (for Ranges 1-4)
HIGH-STAB/CONT TUNE	::	'CONT TUNE'
PEAK-RF/AE TRIM	::	As required for maximum signal.
AERIAL ATTENUATOR	::	'0dB'
IF & AF GAINS	::	To provide required level of output.
MODE SWITCH	::	'SSB HIGH-STAB'
SELECTIVITY	::	'3kHz'
MANUAL/AGC	::	'MANUAL'
CAL ADJ	::	Mid-position (coincident with fixed index).

Before commencing alignment, check that RV2 (AFC ADJ) is set correctly. With the control settings indicated above, RV2 should be adjusted for +8V at Module Pin 34 (AFC outlet from 935kHz Loop Module).

Select each range in turn, tuning to marker signal by adjustment of appropriate trimmer or core, after setting main dial to marker frequency. Adopt normal alignment procedure, tuning trimmers at HF end of range and cores at LF end. Repeat each adjustment several times to achieve correct calibration at both ends of each range simultaneously. All adjustments should be made for zero-beat on the low ranges, but on the higher frequencies, where this adjustment becomes more difficult, setting for an audible output will suffice. Check scale accuracy at main intermediate calibration marks after completion of alignment.

It may be found convenient on the HF ranges, to take advantage of the high-stability facilities when carrying out MTO alignment. This eliminates the need for an external frequency standard; the correct procedure to adopt is as follows:-

1. Set dial to required alignment point (from Table).
2. Select 'SET' position of HIGH-STAB/CONT TUNE SWITCH.
3. Adjust trimmer or core (as appropriate) for illumination of HIGH-STAB LEGEND.
4. Revert to 'CONT TUNE'.
5. Check that correct 100kHz point has been selected by counting from nearest 1MHz marker supplied by integral calibrator.

For Service Manuals Contact  
**MAURITRON TECHNICAL SERVICES**  
 8 Cherry Tree Rd, Chinnor  
 Oxon OX9 4QY  
 Tel:- 01844-351694 Fax:- 01844-352554  
 Email:- enquiries@mauritron.co.uk

#### Signal-frequency Circuits (Turret Disks "A", "B" & "C")

Disconnect frequency standard and connect standard signal generator to LOW-Z aerial input socket. Generator must be matched to 75-ohms, and modulated 30% at either 400Hz or 1kHz. Transfer MODE SWITCH to 'AM' position.

The signal-frequency circuits are located on Disks "A", "B" & "C". Those on Disk "A" are for Ranges 1-4 only (i.e. where bandpass input circuits are employed). In addition, this same disk also carries IF rejection filters for Ranges 4, 5, 6, 7 & 8, but further adjustment of these will not normally be required after initial factory alignment.

Adjustments should be carried out at each of the alignment points indicated in the Table on the following page, tuning the appropriate trimmer or core for maximum output. The integral meter can be used as output indicator (METER SWITCH at 'AF'). No special procedures are involved, other than correct setting of the PEAK-RF/AE TRIM CONTROL to suit the range in use. On Ranges 5-10, this control should be set permanently to mid-travel. On Ranges 1-4, settings should be as follows:-

- When making adjustments at HF ends of ranges :: mid-travel.  
 When making adjustments at LF ends of ranges :: anti-clockwise to end stop.

TABLE OF ALIGNMENT FREQUENCIES AND ADJUSTMENTS

RANGE	ALIGNMENT FREQS.		ALIGNMENT ADJUSTMENTS							
	TRIMMER	CORE	DISK "A"	DISK "B"	DISK "C"	DISK "D"	DISK "E"	DISK "F"		
1	29.0MHz	20.1MHz	C380 L36	C400 L44	C420 L54	C451 L64	C480 L74	C490 L78		
2	19.0MHz	10.0MHz	C383 L37	C404 L45	C424 L55	C453 L65	C484 L75	C494 L79		
3	9.6MHz	4.1MHz	C386 L38	C405 L46	C425 L56	C456 L66	C485 L76	C495 L80		
4	3.9MHz	1.62MHz*	C387 L39	C406 L47	C426 L57	C457 L67	C487 L77	C497 L81		
5	1580kHz	700kHz	- -	C407 L48	C427 L58	C461 L68	*Main Tuning at 1.6MHz and Incremental set to 20kHz			
6	660kHz	300kHz	- -	C408 L49	C428 L59	C462 L69	- -	- -		
7	275kHz	130kHz	- -	C409 L50	C429 L60	C467 L70	- -	- -		
8	125kHz	55kHz	- -	C410 L51	C432 L61	C468 L71	- -	- -		
9	54kHz	26kHz	- -	C411 L52	C433 L62	C472 L72	- -	- -		
10	23kHz	10.5kHz	- -	C412 L53	C438 L63	C473 L73	- -	- -		

## Harmonic Selector Circuits (Turret Disks "E" & "F")

These two disks are operative only when using the receiver in its high-stability mode on Ranges 1-4. The four tuned circuits on each of the disks are aligned to track 400kHz higher in frequency than the indicated frequency on the main tuning scale. Misalignment will cause a reduction in the level of selected harmonic drive to the 1st Loop Mixer (TR7), so reducing conversion gain at the 2nd Signal Mixer (TR15). A clear indication of misalignment is failure of the HIGH-STAB INDICATOR to light at all 100kHz settings in a given range. Very severe misalignment at the high end of Range 1 could result in selection of the loop image frequency, producing errors in dial setting. It can be seen therefore that accurate alignment of the two selector circuits is vital to proper working of the loop system.

Initial factory alignment is carried out by introducing at coaxial entry "G" (harmonic drive feed to Disk "F"), a substitute signal derived from a generator tuned 400kHz higher than the indicated tune frequency. Signal level is adjusted to be of the order 250uV.

This procedure is not necessary in subsequent re-alignment, except where excessive mistuning has occurred. In the normal case, the relevant circuits will be so close to their correct tuning points that it will be possible to utilise the harmonic drive available from the Master Oscillator Unit. An external generator is totally unnecessary.

Visual indication of correct alignment is achieved by patching a valve voltmeter into coaxial lead "M" (935kHz drive to 2nd Loop Mixer). This monitoring arrangement is preferred to other methods which could be used because of the very sharp indication of tuning which it provides. Other arrangements will give the impression of very flat tuning due to the sensibly constant conversion which obtains in the 2nd Loop Mixer for wide variation in injection level.

Access to the required metering point can be obtained by connecting in series, the two coaxial test leads supplied with the receiver, using these to form a link between the two halves of coaxial connector "M". Some reduction in overall receiver sensitivity will be apparent due to the increased attenuation caused by the greater length of coaxial interconnection "M". This however, is of little consequence, since the prime object is to provide a clear indication of tuning without the need for performance checks of any kind.

The receiver should be tuned to each of the alignment points indicated in the Table on the opposite page, using the HIGH-STAB INDICATOR as a check on correct tuning. The appropriate trimmers and cores are tuned for maximum reading on the valve voltmeter, adjustments being repeated several times to ensure accurate alignment. A careful check should be made on completion of the adjustments on each range, to determine that correct tracking of the selector circuits is achieved at all intermediate 100kHz points.

### Re-alignment of L1

On completion of re-alignment of Disks "E" and "F", a check can be made on correct setting of the core in L1. The receiver should be operated in the high-stability mode, tuned to any 100kHz point for illumination of the HIGH-STAB INDICATOR. With the HIGH-STAB/CONT TUNE SWITCH moved into the 'OPERATE' position, trim the core in L1 for maximum reading on the valve voltmeter connected as for alignment of Disks "E" and "F".

NB Access to L1 is by removal of the cover over the front section of the Turret Assembly.

## REMOVAL AND INSTALLATION OF MODULES, UNITS ETC.

Standard Modules (250kHz IF etc.)	Page 64
FSK Module	64
Aerial Attenuator Unit	64
Master Oscillator Unit	65
Incremental Oscillator Unit	65
CW/SSB Detector & BFO Unit	65
3-ohm Output Stage	65
100kHz IF Filter Unit	66
SSB Filter	66
Turret Disks	66
Front Panel Assembly	67
Tuning Drive Assembly	67
Turret Assembly	68
Switch Assembly S3A-E	68

### Standard Modules (250kHz IF, 935kHz Loop etc.)

1. Stand receiver chassis on left-hand side.
2. Remove leads from appropriate module pins.
3. Locate coaxial interconnectors on any associated coaxial leads. Unplug connectors after making careful note of cable dressing etc.
4. Remove the two retaining screws on underside of chassis, complete with shakeproof washers, taking care to note any earth tag which may be retained by these screws. The module should be supported as screws are removed.
5. Lift module free of chassis.
6. Fit replacement module by reversing procedure detailed above, taking care to re-fit solder tag earths etc.

### FSK Module (Not fitted unless specified at time of order)

1. Stand receiver on right-hand side plate.
2. Free the seven module leads from the dummy termination strip (Nos. 79, 81, 82, 83, 84, 87 & 86).
3. Take out two 4BA retaining screws and remove termination strip.
4. Place FSK Module in position and replace the two 4BA retaining screws with shake-proof washers (and earth tag to lead No. 79). Check that screws are secure.
5. Connect seven leads to module, using number sequence stamped on chassis.
6. Connect coaxial lead "W" to spare socket on FSK side of 4-way (or 3-way) junction box (100kHz input to FSK Module).

### Aerial Attenuator Unit

1. Disconnect two-way polarised connector PL/SK-D.
2. Unsolder leads "B" and "C" from HIGH-Z input terminals, and lead "D" from turret contacts.
3. Unscrew and release BNC socket (LOW-Z input).
4. Pull dolly off AERIAL ATTENUATOR SWITCH.
5. Free unit by removing two screws holding bracket to flat strip between panel handle screws.
6. Fit replacement unit by reversing procedure detailed above.

### Master Oscillator Unit

1. Disconnect four leads (Nos. 74, 76, 77 & 78).
2. Remove two 4BA screws to free earth lead on pin 76 and 0.1µF capacitor C139.
3. Remove coaxial plug "I" at CW/SSB Detector & BFO Unit.
4. Remove cover over front section of Turret Assembly to gain access to unsolder the double-screened coaxial lead "G".
5. Remove four 6BA screws retaining unit, supporting with free hand. Note that three of the screws also retain cable clips, and that all screws are fitted with washers.
6. Fit replacement unit by reversing procedure detailed above, remembering to re-fit the solder tag from pin 76 and the 0.1µF capacitor earthing tag. Note that coaxial lead "G" has its outer screen connected directly to the turret casting.

### Incremental Oscillator Unit

1. Disconnect two leads Nos. 18 & 19.
2. Disconnect coaxial plugs "N" & "O".
3. Remove PL/A from SK/A (for ease of access to fixing screws).
4. Slacken the two screws in rear component of flexible coupler (access from below).
5. Use open-ended spanner to remove the four 4BA hex-headed screws holding unit to rear drive plate (support unit at this stage).
6. Slide unit to rear to disengage spindle from flexible coupler. Lift clear in downward direction.
7. Fit replacement unit by reversing procedure detailed above.
8. Set dial to HF end-stop (line marked on scale). Remove bottom cover from unit and set capacitor to maximum capacity setting.
9. Lock coupler screws, replace bottom cover and verify scale accuracy.

### CW/SSB Detector & BFO Unit

1. Remove BFO control knob and skirt (separate item).
2. Disconnect leads Nos. 57, 58, 59, 61 & 62.
3. Disconnect coaxial plugs "I" & "V".
4. Remove cover from 100kHz IF Module (two screws on top).
5. Remove the four 6BA screws with shakeproof washers which retain the unit on right-side plate. Slide unit to rear and upward to remove.
6. Fit replacement unit by reversing procedure detailed above. Take care when re-fitting skirt to check that this is attached so that index registers against panel marking.

For Service Manuals Contact  
**MAURITRON TECHNICAL SERVICES**  
8 Cherry Tree Rd, Chinnor  
Oxon OX9 4QY  
Tel: 01844-351694 Fax: 01844-352554  
Email: enquiries@mauritron.co.uk

### 3-ohm Output Stage

1. Disconnect leads Nos. 92 & 93.
2. Remove the two 4BA screws retaining unit.
3. Lift clear to permit unsoldering lead No. 91 and associated screening braid.
4. Fit replacement unit by reversing procedure detailed above.

### 100kHz IF Filter Unit

1. Remove CW/SSB Detector & BFO Unit. (See previous page).
2. Disconnect lead No. 56, and coaxial leads "Q", "R", "S" & "T".
3. Remove SELECTIVITY control knob.
4. Remove the two 6BA screws with shakeproof washers located adjacent to coaxial sockets "S" & "T".
5. Remove 3/8" panel nut (SELECTIVITY SWITCH), and slide unit towards rear of set. Take care not to lose the large shakeproof washer which is located behind panel, concentric with control spindle bush.
6. Fit replacement unit by reversing procedure detailed above. Remember to re-fit the large washer removed in (5) above. Replace CW/SSB Detector & BFO Unit.

### SSB Filter

1. Remove covers over coaxial terminations "R" & "S" on right-hand side plate.
2. Unsolder coaxial leads (inner conductor only), and lift 1,000-ohm resistors.
3. Remove the four 4BA nuts (with shakeproof washers) and slide filter inwards, then upwards to remove.
4. Fit replacement filter by reversing procedure detailed above.

### Turret Disks (Removal)

1. Remove cover plate from left-hand side of turret assembly, and top cover plate which carries the disk identification.
2. Select Range 1 (20-30MHz).
3. Stand receiver on right-hand side plate.
4. Grip edge of disk firmly between finger and thumb, pulling vertically upwards so that slot in disk slides smoothly across spindle.

### Turret Disks (Replacement)

1. Check that disk clip (on spindle) is correctly aligned with contact assembly, and guide at bottom of turret. Slide along spindle if necessary for correct position.
2. Orientate disk so that the side marked "FRONT" is towards panel.
3. Insert Disk Insertion Tool to open contact fingers.
4. Position disk so that its slot lines up with the spindle clip.
5. Push disk gently downwards to enter Disk Insertion Tool.
6. Withdraw Disk Insertion Tool.
7. Check for accurate positioning of disk and smooth operation of turret.
8. Check electrical alignment as described on pages 60-63.
9. Replace turret covers.

For Service Manuals Contact  
MAURITRON TECHNICAL SERVICES  
8 Cherry Tree Rd, Chinnor  
Oxon OX9 4QY  
Tel: 01844-351694 Fax: 01844-352554  
Email: enquiries@mauritron.co.uk

### Front Panel Assembly

1. Place receiver on right-hand side plate for operations 2, 3 & 4 below. Invert to rest on left-hand side for remaining operations. It will be found most convenient to allow the panel to protrude over the edge of the work bench.
2. Remove Aerial Attenuator Unit (see page 64, but ignore operations 2 and 3 since total removal is unnecessary).
3. Remove the following control knobs etc.

MAIN TUNING	*Also remove control knob skirt which is separate from knob proper.
INCREMENTAL TUNING	
RANGE SWITCH	**Also remove 3/8" panel nut concentric with spindle bush. Note that there is a large shakeproof washer on this bush at the reverse side of the panel. This should be removed and stored in a safe place after taking off the panel.
BFO*	
SELECTIVITY**	
4. Remove panel nut to free SUPPLY SWITCH. Push switch through panel and leave floating free. (Note: All other panel leads are routed via the 37-way connector PL/SK-B).
5. Remove two screws holding panel to right-hand side plate, i.e. screws retaining the panel handle.
6. Remove the four screws which attach the two panel brackets to the drive mounting points (two at left-hand side just in front of turret, two near centre of panel).
7. Pull panel clear, at same time releasing PL/B from SK/B (towards right-hand end of panel assembly at left of MODE SWITCH).
8. Replace panel by reversing procedure detailed above. Take care to replace the large washer on the SELECTIVITY SWITCH spindle bush.

### Tuning Drive Assembly (See note on page XXXIV)

1. Remove panel as described above.
2. Remove Incremental Oscillator Unit (see page 65).
3. Slacken the four screws in rear component of flexible coupler in turret drive.
4. Slacken the four screws in rear component of flexible coupler in main tuning gang drive.
5. Remove PL/A from SK/A.
6. Disconnect both coaxial interconnectors coded "H", and those coded "E", "J", "K" & "L".
7. Remove 250kHz IF Module (see page 64). This allows access to one fixing screw which secures drive assembly to main chassis. Remove this screw (below chassis on flange).
8. Remove the four screws which retain drive assembly to turret casting. One of these screws is fitted from inside of turret - gain access by removing left-hand turret cover and Disk "F".
9. Fit replacement drive assembly by reversing procedure detailed above. Flexible coupler to main tuning gang should be locked to spindle with capacitor set to maximum capacity and tuning drive at LF end stop (line marked on scale).

**NB** All drive bearings and other mechanical items are lubricated with molybdenum disulphide during initial assembly. Further lubrication should normally not be required, but can be carried out if felt necessary after the receiver has been in use for a number of years.

### Turret Assembly

1. Remove turret covers and unsolder coaxial leads "D", "F" and "G". Leave cable clips for leads "A", "B", "C" and "D" floating free.
2. Disconnect leads linking Peak-RF Board to main RF Unit.
3. Disconnect leads Nos. 2, 3, 4, 5, 6, 7\* and 8. (Unsolder lead marked \*)
4. Remove Panel Assembly (see page 67).
5. Remove Drive Assembly (see page 67). Incremental Oscillator Unit can be left in position.
6. Remove three screws retaining rear left-hand corner of turret casting.
7. Remove two screws retaining right-hand side of turret casting (access from below).
8. Turret is now free and can be lifted clear.
9. Fit replacement turret by reversing procedure detailed above.

### Switch Assembly S3A-E

1. Set RANGE SWITCH to Range 4.
2. Slacken rear screw in switch spindle coupler.
3. Slacken the two hex-headed screws retaining switch assembly mounting plate.
4. Rotate plate slightly so that screw heads lie in wide part of keyhole cut-out.
5. Pull gently to rear to free spindle from coupler.
6. For total removal, disconnect coaxial interconnectors "E", "H" (2), "J", "K" & "L", and fixed socket SK/A.
7. Replace assembly by reversing procedure detailed above. Check that switch wiper is aligned correctly and operates in sympathy with motion of RANGE SWITCH.

For Service Manuals Contact  
MAURITRON TECHNICAL SERVICES  
8 Cherry Tree Rd, Chinnor  
Oxon OX9 4QY  
Tel:- 01844-351694 Fax:- 01844-352554  
Email:- enquiries@mauritron.co.uk

## APPENDIX "A"

### OPERATING THE EC958 RECEIVER FROM LOW-VOLTAGE DC SUPPLIES

#### General

The EC958 Receiver can be installed with a DC/AC Converter Unit for operation from low voltage DC supplies. The units available provide conversion efficiencies of the order 80% and are designated as follows:-

DC/AC Converter Type 978/12                   ::           for 12V working  
DC/AC Converter Type 978/24                   ::           for 24V working

Both units provide a nominal 50Hz square-wave output of 250V and are basically identical. The notes which follow refer to either type.

#### Input

A heavy gauge cable is provided for connection to an accumulator, leads being coded RED +ve and BLACK -ve. If extension of the existing leads proves necessary to suit the installation, care should be taken to select a suitable cable to avoid excessive voltage drop. Neither pole of the supply is earthed.

**WARNING:** Under no circumstances should the unit be connected to a supply source other than an accumulator, unless such source is shunted with an accumulator of the correct voltage required. Place unit well clear of battery fumes.

#### Switching

Switching of the input supply is achieved by means of an internal relay. The circuit includes a reverse-polarity protection diode to prevent operation of the relay in the event of the input leads being inadvertently reversed.

Provision is made for local or remote switching, connection for the latter being to a terminal block on the front of the unit. A single-pole switch is required.

**REMOTE SWITCHING :** Supply switch on unit must be left permanently in 'ON' position.  
**LOCAL SWITCHING :** Terminal block connections must be shorted with wire link.

#### Fusing

Input is fused by an internal fuse link of rating specified on label.

#### Earthing

The case of the unit should be effectively earthed. A terminal is provided for this purpose.

#### Output

A suitable connector is supplied with unit. A surge-limiting inductor is included in the output circuit.

Maximum output rating 50 watts.

#### Case Dimensions

Approximately 8 in x 6in x 4in.

For Service Manuals Contact  
**MAURITRON TECHNICAL SERVICES**  
8 Cherry Tree Rd, Chinnor  
Oxon OX9 4QY  
Tel: 01844-351694 Fax: 01844-352554  
Email: [enquiries@mauritron.co.uk](mailto:enquiries@mauritron.co.uk)

APPENDIX "B"

VOLTAGE ANALYSIS

In the event of the receiver failing to operate normally, initial voltage checks should be carried out at all appropriate module terminations etc. to determine whether the fault lies in the circuit wiring or in one of the modules or units. If the latter should prove to be the case, most modules etc. can be easily taken out and then re-connected with covers removed to allow access for checking the voltages on any suspected stage. Two separate Voltage Analysis Tables are provided here, the first covering voltage checks on module terminations etc., and the second giving a full summary of the stage voltages throughout the entire receiver.

Voltages quoted in both Tables were taken with a standard 20,000 ohms/volt multi-range testset and an applied supply voltage of 240V AC (using 230/250V tapping). A tolerance of 10% should be allowed on all readings to cover zener and semiconductor spreads; greater variation should be allowed if readings are taken with a less sensitive meter than that specified.

Controls should be adjusted initially as indicated below, settings being altered as necessary for the check being carried out (see Remarks column).

RANGE SWITCH	::	Range 1
MAIN TUNING	::	20MHz
INCREMENTAL	::	'0'
PEAK-RF/AE TRIM	::	Fully clockwise
HIGH-STAB/CONT TUNE	::	"OPERATE" (*)
SIGNAL MODE	::	'CW/SSB'
USB/LSB SWITCH	::	'USB'
IF GAIN	::	Maximum
METER SWITCH	::	'RF'
MANUAL/AGC SWITCH	::	'MANUAL'
CALIBRATOR SWITCH	::	'OFF'

(\*) Receiver tuned to illuminate 'HIGH-STAB' legend.

VOLTAGE TABLE 1 - MODULE SUPPLIES ETC.

Module/ Unit etc.	Pin	Service	Voltage/Remarks
RF Assembly	1	IC1 supply	+12V with CALIBRATOR SWITCH pressed.
	2	Metering connection	+14.2V with METER SWITCH at 'RF'. +14.3V with METER SWITCH at 'CZ' or 'AF'.
	3	TR1-TR3 supply	+15V under all conditions of switching.
	4	RF AGC	+1.3V under no-signal conditions.
	5	TR4-TR5 supply	+12V under all conditions of switching except when NORMAL/SYNTH SWITCH is set to 'SYNTH' position (0V).
	6	AFC line to D11	+8V with HIGH-STAB/CONT TUNE SWITCH at 'CONT TUNE' or 'SET' positions.
	7	TR6, TR7 & IC2 supply	+15V except when HIGH-STAB/CONT TUNE SWITCH is set to 'CONT TUNE' position.
	8	IC2 supply	-6V under all conditions of switching.

(II)

For Service Manuals Contact  
**MAURITRON TECHNICAL SERVICES**  
 8 Cherry Tree Rd, Chinnor  
 Oxon OX9 4QY  
 Tel:- 01844-351694 Fax:- 01844-352554  
 Email:- enquires@mauritron.co.uk

Module/ Unit etc.	Pin	Service	Voltage/Remarks
RF Assembly	9	Control voltage to D5/6 & D9/10	Dependent on Range in use and setting of PEAK-RF/AE TRIM:- Range 1 8.5-15V. Range 4 0.2-15V. Range 2 3.5-15V. Ranges 5-10 fixed Range 3 1.5-15V. at 15V.
	10	Control voltage to D7/8	Ranges 1-4 identical to pin 9 above. Ranges 5-10 3.5-15V.
	11	Fixed control voltage to D5/6 & D9/10	+15V.
Aerial Attenuator Unit	12	Muting Relay control line (external)	+12V derived from external source.
	13	Ditto (internal)	+12V with CAL button pressed.
	14-17		Not allocated.
Incremental Oscillator Unit	18	Control voltage to D46	+1.5V with link fitted between PL/C-2 & PL/C-3. 0-+5V with external 10,000 ohm control
	19	TR17-19 supply	+12V under all conditions of switching except when NORMAL/SLAVE SWITCH is set to 'SLAVE' position (0V).
	20 25 26		Not allocated.
Tunable IF Module	21	Earth	+15V under all conditions of switching. Dependent on setting of INCREMENTAL TUNING CONTROL:- INC. Fully Anti clock 15V INC. '100' 5V
	22	TR15 & IC12 supply	
	23	Control voltage to D19/24	
	24	Earth	
	30-35		Not allocated.
935kHz Loop Module	27	'HIGH-STAB' lamp supply	+12V (Derived from supply to Pin 28). Available only in 'HIGH-STAB' positions of HIGH-STAB/CONT TUNE SWITCH with Rec. tuned to 0.1MHz point on Ranges 1-4.

(III)

For Service Manuals Contact  
MAURITRON TECHNICAL SERVICES  
8 Cherry Tree Rd, Chinnor  
Oxon OX9 4QY  
Tel:- 01844-351694 Fax:- 01844-352554  
Email:- enquiries@mauritron.co.uk

Module/ Unit etc.	Pin	Service	Voltage/Remarks
935kHz Loop Module	28	Supply to TR9-11 & IC3-4	+12V. Available only on Ranges 1-4 with HIGH-STAB/CONT TUNE SWITCH in 'HIGH-STAB' positions.
	29	Supply to IC5	-6V under all conditions of switching.
	31	Earth	
	32	Supply to IC5	+12V. Available only on Ranges 1-4 with HIGH-STAB/CONT TUNE SWITCH at 'CONT TUNE'.
	33	Supply to TR8	+12V under all conditions of switching.
	34	AFC	(see Pin 6).
	36	AFC Adjuster	Dependent on setting of RV2. Of the order +1V.
	37	Discriminator o/p	Earthed with HIGH-STAB/CONT TUNE SWITCH at 'CONT TUNE' and 'SET'.
	39		Not allocated.
	40		
250kHz IF Module	38	Supply to TR20, TR21, TR22 & IC7.	+12V except on Ranges 7, 9 & 10.
	41	Supply to IC7	-2.7V under all conditions of switching when 250kHz IF is in use.
	42	Control voltage to D28	-6V with USB/LSB SWITCH at 'LSB'.
	43	Earth	
	44	Control voltage to D27	-6V with USB/LSB SWITCH at 'USB'.
	45	Earth	
	46		Not allocated.
	47		
	50		
100kHz IF Amplifier Module	48	IF AGC	Varies between 0V and -3V for full travel of IF GAIN CONTROL (with MANUAL/AGC SWITCH at 'MANUAL').
	49	Earth	
	51	Audio output	From AM Detector.
	52	IF AGC	Output from IF AGC Rectifier.
	53	Supply to TR23-31	+12V under all conditions of switching.
	54	Earth	
	55	RF AGC	Output from RF AGC Rectifier (1.3V under no-signal conditions).

(IV)

For Service Manuals Contact  
**MAURITRON TECHNICAL SERVICES**  
 8 Cherry Tree Rd, Chinnor  
 Oxon OX9 4QY  
 Tel:- 01844-351694 Fax:- 01844-352554  
 Email:- enquiries@mauritron.co.uk

Module/ Unit etc.	Pin	Service	Voltage/Remarks
100kHz IF Filter Unit	56	Supply to TR3 or TR20 drain	+12V under all conditions of switching.
	60		Not allocated.
CW/SSB Detector & BFO Unit	57	Supply to TR32	Available with MODE SWITCH at 'CW/SSB' position only. (+12V)
	58	Earth	
	59	Audio output	From CW/SSB Detector.
	61	Supply to TR33	+12V under all conditions of switching.
	62	Earth	
	70		Not allocated.
Audio Amplifier Module	63	600 ohm output	
	64	600 ohm centre-tap	
	65	600 ohm output	
	66	Meter Rectifier o/p	Approximately 3V for 10mW noise on panel meter.
	67	Audio input from RV6	
	68	Audio input from RV7	
	69	Supply to TR34-37	+15V under all conditions of switching.
	71	Audio output from driver transformer	
	72	Earth	
	73		Not allocated.
	75		
Master Oscillator Unit	74	Supply to TR13	+12V. Available only with MODE SWITCH at 'SSB HIGH-STAB' position.
	76	Earth	
	77	Supply to 1MHz Crystal Oscillator, TR12, TR14 & IC6	+12V under all conditions of switching.
	78	Supply to Oven	12.6V AC available continuously.
	80		Not allocated.
	85		

(V)

For Service Manuals Contact  
MAURITRON TECHNICAL SERVICES  
8 Cherry Tree Rd, Chinnor  
Oxon OX9 4QY  
Tel: 01844-351694 Fax: 01844-352554  
Email: enquiries@mauritron.co.uk

Module/ Unit etc.	Pin	Service	Voltage/Remarks
FSK Module	79	Earth	
	81	Discriminator o/p	Feed to meter circuit ('CZ' position).
	82	Supply to IC9 & IC10	-6V under all conditions of switching.
	83	Supply to all FSK Stages	+12V. Available only with MODE SWITCH at 'CW/SSB' setting.
	84		
	86	FSK Relay contacts	
	87		
	88- 90		Not allocated.
3-ohm Output Stage	91	Audio drive	
	92	Supply to TR38	+15V under all conditions of switching.
	93	Collector of TR38	+14.5V.
	94	3-ohm secondary	
	95	3-ohm secondary	Earthy side. Free from earth with Tel. plug inserted in panel jack.
	96 & 100		Not allocated.
S4 & S6	97	Supply to TR4, 5, 17, 18&19.	+12V
	98	Supply via S4 to TR4 & TR5.	+12V with S4 at 'NORMAL'.
	99	Supply via S6 to TR17, 18 & 19.	+12V with S6 at 'NORMAL'.
Meter Board	101	RV12	} DC output from meter rectifier on } 600-ohm channel.
	102	RV12	
	103	RV4	Alignment potentiometer for Tunable IF.
	104	RV2	See Pin 36.
	105	Earth	
	106	Gate of TR39	
	107	Drain of TR39	
	108	RV11 slider	+14V nominal.
	109	RV10	AF ZERO SET.
	110	RV9	FSK CZ SET.
	111	Supply to TR39	+15V under all conditions of switching.
Power Unit	112- 130	+12V, +15V and -6V supplies	See Interconnection circuit.

(VI)

For Service Manuals Contact  
**MAURITRON TECHNICAL SERVICES**  
 8 Cherry Tree Rd, Chinnor  
 Oxon OX9 4QY  
 Tel:- 01844-351694 Fax:- 01844-352554  
 Email:- enquiries@mauritron.co.uk

VOLTAGE TABLE 2 - STAGE VOLTAGES

NB Control settings should be as detailed on page II, except where modified by the Notes listed in the right-hand column. Tolerances etc. specified previously apply to all readings given below. Voltages are +ve w. r. t. earth unless indicated.

TRANSISTORS

Ref	Emitter / Source	Base / Gate / Gate 1	Gate 2	Collector / Drain	Notes
TR1	1.1V	0V	-	3V	NOTE 1
TR2	3V	1.3V	-	14.2V	NOTE 1
TR3	0.7V	0V	0.8V	13V	NOTE 14
TR4	1V	-1.5V	-	12V	NOTE 2
TR5	4V	3.5V	-	11.2V	NOTE 2
TR6	0.8V	0V	-	14.4V	NOTE 3
TR7	0.8V	0V	0.8V	14.7V	NOTE 3
TR8	1V	0V	-	7.9V	NOTE 3
TR9	0V	0.6V	-	11.3V	NOTE 3
TR10	0.1V	-2V	-	3V	NOTE 3
TR11	0.1V	0.7V	-	1.2V	NOTE 3
TR12	1.7V	2.2V	-	9.6V	-
TR13	0.3V	1V	-	11.4V	NOTE 5
TR14	1.4V	2.1V	-	11.4V	-
TR15	0.65V	0V	1.5V	11.4V	NOTE 6
TR16*	-	-	-	-	-
TR17	1.9V	0V	-	8V	NOTE 7
TR18	3.1V	3.4V	-	10V	NOTE 7
TR19	3.5V	3.4V	-	10V	NOTE 7
TR20	0.55V	0V	1.0V	11.9V	NOTE 15
TR21	2.5V	0V	-	12V	NOTE 15
TR22	2.1V	3V	-	11.8V	NOTE 15
TR23	2.3V	0V	-	10.2V	NOTE 8
TR24	2.3V	0V	-	10.2V	NOTE 8
TR25	2.3V	0V	-	10.2V	NOTE 8
TR26	2.3V	0V	-	10.2V	-
TR27	0V	0.6V	-	10.7V	-
TR28	2.3V	0V	-	10.1V	-
TR29	0V	0.8V	-	9.4V	-

(\*) Reference not allocated.

(VII)

For Service Manuals Contact  
**MAURITRON TECHNICAL SERVICES**  
 8 Cherry Tree Rd, Chinnor  
 Oxon OX9 4QY  
 Tel:- 01844-351694 Fax:- 01844-352554  
 Email:- enquiries@mauritron.co.uk

Ref	Emitter / Source	Base / Gate / Gate 1	Gate 2	Collector / Drain	Notes
TR30	2.3V	0.6V	-	10.7V	-
TR31	0V	0.75V	-	8.2V	-
TR32	0V	-0.1V	-	10V	NOTE 9
TR33	1V	0V	1.1V	10V	-
TR34	0.85V	0.5V	-	6V	-
TR35	1.62V	1.95V	-	14.5V	-
TR36	0.45V	0.7V	-	7.1V	-
TR37	1.2V	1.8V	-	14.5V	-
TR38	0.6V	1.3V	-	14.5V	-
TR39	1.1V	0V	-	13.8V	NOTE 10
TR40	0.6V	0V	-	6.2V	NOTE 9
TR41	0.4V	1V	-	-0.2V	NOTE 9

INTEGRATED CIRCUITS

Ref	1	2	3	4	5	6	7	8	9	10	11	12	13	14	Notes
IC1	12V	8V	0V	6V	2.4V	2V	0V	6.3V	6.3V	8.2V	-	-	-	-	11
IC2	0.5V	3.2V	3.8V	15V	0V	0V	-0.3V	0V	0V	-6V	-5.2	-9.5	0V	0V	3
IC3	0V	-6V	-6V	-6V	0V	1.5V	0V	1.5V	6V	0V	-	-	-	-	4
IC4	1.7V	1.7V	1.7V	1.7V	5.4V	0V	0V	0V	0V	5.4V	-	-	-	-	4
IC5	0V	0V	-6V	-4V	-3.7	0V	0V	4V	8.4V	4.1V	-	-	-	-	12
IC6	3.1V	0V	0V	0V	5.8V	0V	0V	2V	2V	0V	1V	2.2V	0V	1V	-
IC7	0V	0V	-2.9	0.2V	-1.2	0V	0V	4.5V	6.4V	4.5V	-	-	-	-	13
IC8	1.7V	1.7V	1.7V	1.7V	5.4V	0V	0V	0V	0V	5.4V	-	-	-	-	9
IC9	0V	-6V	-6V	-6V	0V	1.5V	0V	1.5V	6V	0V	-	-	-	-	9
IC10	0V	-6V	-6V	-6V	0V	1.5V	0V	1.5V	6V	0V	-	-	-	-	9
IC12	0V	2.4V	2.4V	5.5V	5.5V	0V	2.3V	0V	-	-	-	-	-	-	-

1MHz MASTER OSCILLATOR

1	2	3	4	5	6	7	8
12.6V AC	6.2V	-	-	0V	-	0V	0V

(VIII)

For Service Manuals Contact  
**MAURITRON TECHNICAL SERVICES**  
 8 Cherry Tree Rd, Chinnor  
 Oxon OX9 4QY  
 Tel:- 01844-351694 Fax:- 01844-352554  
 Email:- enquiries@mauritron.co.uk

## VOLTAGE TABLE 2 - NOTES

- NOTE 1. Figures quoted are for all ranges except Ranges 7, 9 & 10. On these three ranges, voltages are modified as follows :-
- |           |    |       |            |    |       |
|-----------|----|-------|------------|----|-------|
| TR1 Drain | :: | 3.5V. | TR2 Source | :: | 3.5V. |
|           |    |       | Drain      | :: | 5.5V. |
- NOTE 2. NORMAL/SYNTH SWITCH set to 'NORMAL' position.
- NOTE 3. HIGH-STAB/CONT TUNE SWITCH in 'SET' position and receiver tuned to light the 'HIGH-STAB' legend.
- NOTE 4. Voltages present on Ranges 1-4 only, with HIGH-STAB/CONT TUNE SWITCH at 'SET' or 'OPERATE'.
- NOTE 5. MODE SWITCH set to 'SSB HIGH-STAB' position.
- NOTE 6. Drain voltage removed on Ranges 7, 9 & 10.
- NOTE 7. NORMAL/SLAVE SWITCH set to 'NORMAL' position.
- NOTE 8. MANUAL/AGC SWITCH at 'MANUAL' and IF GAIN at maximum setting.
- NOTE 9. MODE SWITCH at 'CW/SSB' position.
- NOTE 10. Readings recorded after setting meter adjustments for correct zero etc.
- NOTE 11. CALIBRATOR SWITCH pressed.
- NOTE 12. Check on Ranges 1-4 with HIGH-STAB/CONT TUNE SWITCH at 'CONT TUNE' setting.
- NOTE 13. USB/LSB SWITCH at 'LSB'.
- NOTE 14. NORMAL/SYNTH SWITCH set to 'NORMAL' position. Voltage on TR3 drain will be lower on Ranges 5-10 (fed from +12V in lieu of +15V line). Additional drop occurs across R119 on Ranges 9 and 10 only.
- NOTE 15. +12V removed from all 250kHz Stages when switched to Ranges 7, 9 & 10. Drain voltage remains on TR20.

**For Service Manuals Contact**  
**MAURITRON TECHNICAL SERVICES**  
8 Cherry Tree Rd, Chinnor  
Oxon OX9 4QY  
Tel:- 01844-351694 Fax:- 01844-352554  
Email:- enquiries@maurtron.co.uk

APPENDIX "C"

SEMICONDUCTOR COMPLEMENT

Ref	Type	Manufacturer	Circuit Function
TR1	UC734B	Union Carbide	) Cascode RF Amplifier
TR2	3N128	RCA	
TR3	40673	RCA	1st Signal Mixer
TR4	3N128	RCA	Main Tune Oscillator (OSC 1)
TR5	UC734B	Union Carbide	Source Follower (Oscillator Buffer)
TR6	UC734B	Union Carbide	Harmonic Amplifier
TR7	40673	RCA	1st Loop Mixer
TR8	UC734B	Union Carbide	AFC Control Amplifier
TR9	2N4254	Texas	Emitter Follower
TR10	UC734B	Union Carbide	) Schmitt Trigger (HIGH-STAB RELAY)
TR11	40309	RCA	
TR12	2N4254	Texas	1MHz Amplifier (Divider Driver)
TR13	BC107B	Mullard	100kHz Emitter Follower (Carrier Insert)
TR14	2N4254	Texas	Emitter Follower (Harmonic Generator)
TR15	40673	RCA	2nd Signal Mixer
TR16			Reference not allocated
TR17	UC734B	Union Carbide	Incremental Oscillator (OSC 2)
TR18	2N4254	Texas	Emitter Follower (Oscillator Buffer)
TR19	2N4254	Texas	Emitter Follower (Not used on standard
TR20	40673	RCA	3rd Signal Mixer Model EC958)
TR21	UC734B	Union Carbide	150/350kHz Oscillator Amplifier
TR22	BC107B	Mullard	250kHz IF Amplifier
TR23	UC734B	Union Carbide	1st 100kHz IF Amplifier
TR24	UC734B	Union Carbide	2nd 100kHz IF Amplifier
TR25	UC734B	Union Carbide	3rd 100kHz IF Amplifier
TR26	UC734B	Union Carbide	4th 100kHz IF Amplifier
TR27	2N4254	Texas	Emitter Follower (100kHz)
TR28	UC734B	Union Carbide	RF AGC Amplifier
TR29	2N4254	Texas	Emitter Follower (RF AGC Rect. Driver)
TR30	UC734B	Union Carbide	IF AGC Amplifier
TR31	2N4254	Texas	Emitter Follower (IF AGC Rect. Driver)
TR32	UC734B	Union Carbide	Beat Oscillator
TR33	40673	RCA	CW/SSB Detector
TR34	BC107B	Mullard	AF Amplifier )
TR35	BC107B	Mullard	AF Output ) Low-level Audio
TR36	BC107B	Mullard	AF Amplifier )
TR37	40309	RCA	AF Driver ) High-level Audio
TR38	2N3054	RCA	AF Output )
TR39	UC734B	Union Carbide	Meter Control Amplifier
TR40	UC734B	Union Carbide	Source Follower (FSK Module)
TR41	BCY34	Mullard	DC Amplifier (FSK Module)

For Service Manuals Contact  
**MAURITRON TECHNICAL SERVICES**  
 8 Cherry Tree Rd, Chinnor  
 Oxon OX9 4QY  
 Tel: 01844-351694 Fax: 01844-352554  
 Email: enquiries@mauritron.co.uk

Ref	Type	Manufacturer	Circuit Function
PC1	8x1N4148	Newmarket	Aerial Protection*
D5-D10	6 x BA111	STC	Peak RF/Ae Trim VVC's
D11	BA110	STC	AFC VVC
D12	1S44	Texas	Bias Diode (Main Tune Oscillator)
D13-D14	2 x 1S44	Texas	935kHz Discriminator
D15	1S44	Texas	HIGH-STAB Lamp Detector
D15A	1S44	Texas	935kHz Peak Clipper
D16	BZY88C5V6	Mullard	Zener Regulator
D17	BZY88C4V7	Mullard	Zener Regulator (1 MHz Peak Clipper)
D18	BZY88C6V2	Mullard	Zener Regulator
D19-21 & D19A-21A	6 x MV1656	Motorola	1st IF VVC's
D22-24 & D22A-24A	6 x MV1656	Motorola	2nd Oscillator VVC's (Injection Tuning)
D25	BZY88C8V2	Mullard	Zener Regulator
D26	OA228	Mullard	Zener Regulator
D27	1S44	Texas	150kHz Oscillator Switch
D28	1S44	Texas	350kHz Oscillator Switch
D29	BZY88C6V2	Mullard	Zener Regulator
D30	-	-	Reference not allocated
D31	1N4004	ITT	12V Switch
D32	OA47	Mullard	AM Detector
D33	1S44	Texas	RF AGC Rectifier
D34	1S44	Texas	IF AGC Rectifier
D35	1S44	Texas	BFO Switch
D36	1S44	Texas	Carrier Insertion Switch
D37	1S44	Texas	Meter Rectifier (600 ohm o/p)
D38-D39	2 x 1S44	Texas	FSK Discriminator (100kHz)
D40	BZY88C6V2	Mullard	Zener Regulator
D41	OA230	Mullard	Zener Regulator
D42	OA232	Mullard	Zener Regulator
D43	S1PB2	Westinghouse	Positive Supply Rectifier (Bridge)
D44	OA223	Mullard	Zener Regulator
D45	OSH01	Mullard	Negative Supply Rectifier (Bridge)
D46	BA111	STC	Remote Tune VVC
IC1	CA3000/V1	RCA	1MHz Crystal Calibrator
IC2	SA21	Sylvania	Main Tune Oscillator Amplifier
IC3	CA3002/V1	RCA	Loop Amplifier (935kHz)
IC4	CA3012/V1	RCA	Loop Limiter (935kHz)
IC5	CA3000/V1	RCA	935kHz Crystal Oscillator
IC6	FJJ141	Mullard	1MHz/100kHz Divider
IC7	CA3000/V1	RCA	150/350kHz Crystal Oscillator (OSC 3)
IC8	CA3012/V1	RCA	FSK Limiter (100kHz)
IC9	CA3002/V1	RCA	FSK Limiter
IC10	CA3002/V1	RCA	FSK Relay Driver
IC11	-	-	Reference not allocated
IC12	SL641C	Plessey	2nd Loop Mixer
			<b>NB: EQUIVALENT TYPES WILL BE FITTED WHEN SPECIFIED TYPES ARE NOT AVAILABLE.</b>

(\* ) D1-D4 (4 x DD006) on early receivers.

(XI)

For Service Manuals Contact  
**MAURITRON TECHNICAL SERVICES**  
8 Cherry Tree Rd, Chinnor  
Oxon OX9 4QY  
Tel: 01844-351694 Fax: 01844-352554  
Email: enquiries@mauritron.co.uk

APPENDIX "D"

LIST OF COMPONENT VALUES, TOLERANCES AND RATINGS

PART 1 :: MAIN RECEIVER

PART 2 :: TURRET DISKS (Page XXIV)

MAIN RECEIVER

Location Code

Each component, in the Tables which follow, is allocated a reference letter which will assist in location. Coding is as follows:-

A : 1MHz Calibrator	H : Incremental Osc.	O : Power Unit Chassis
B : Aerial Attenuator Box	I : 250kHz IF Module	P : Meter Board
C : Peak-RF Board	J : 100kHz IF Filter	Q : Panel Assembly
D : RF Assembly	K : 100kHz IF Amplifier	R : Drive Assembly
E : 935kHz Loop Module	L : CW/SSB Detector & BFO	S : Back Plate
F : Master Osc. Unit	M : Audio Module	T : Main Chassis
G : Tunable IF Module	N : FSK Module	

Capacitors

Ref	Value	Type	Tolerance	Wkg. V.	Loc
C1	0.1uF	Polycarbonate	20%	100V	A
C2-C5	-	References not allocated	-	-	-
C6-C7*	0.047uF	Polycarbonate	20%	100V	Q
C8-C9	0.1uF	Polycarbonate	20%	100V	R
C10	0.1uF	Polycarbonate	20%	100V	B
C11-C18	-	References not allocated	-	-	-
C19	0.047uF	Polycarbonate	20%	100V	R
C20	0.1uF	Polycarbonate	20%	100V	C
C21	0.1uF	Polycarbonate	20%	100V	C
C22	0.047uF	Polycarbonate	20%	100V	C
C23	0.047uF	Polycarbonate	20%	100V	C
C24	0.1uF	Polycarbonate	20%	100V	C
C25-C29	-	References not allocated	-	-	-
C30	12-358pF	Air-spaced variable	-	-	D
C31	12-358pF	Air-spaced variable	-	-	D
C32	60pF	Tubular Ceramic	10%	750V	D
C33	0.1uF	Polycarbonate	20%	100V	D
C34	0.1uF	Polycarbonate	20%	100V	D
C35	0.1uF	Polycarbonate	20%	100V	D
C36	0.1uF	Polycarbonate	20%	100V	D
C37	12-358pF	Air-spaced variable	-	-	D
C38	20pF	Tubular Ceramic	10%	750V	D
C39	0.1uF	Polycarbonate	20%	100V	D

(\* ) omitted when not required.

Ref	Value	Type	Tolerance	Wkg. V.	Loc
C40	0.1uF	Polycarbonate	20%	100V	D
C41	0.1uF	Polycarbonate	20%	100V	D
C42	0.1uF	Polycarbonate	20%	100V	D
C43	150pF	Silvered Mica	5%	350V	D
C44	6pF	Tubular Ceramic	10%	750V	D
C45	0.1uF	Polycarbonate	20%	100V	D
C46	18-364pF	Air-spaced variable	-	-	D
C47	100pF	Silvered Mica	5%	350V	D
C48	0.1uF	Polycarbonate	20%	100V	D
C49	0.1uF	Polycarbonate	20%	100V	D
C50	0.047uF	Polycarbonate	20%	100V	D
C51	100pF	Silvered Mica	5%	350V	D
C52	0.047uF	Polycarbonate	20%	100V	D
C53	0.1uF	Polycarbonate	20%	100V	D
C54	0.01uF	Metallised Paper	20%	200V	D
C55	0.1uF	Polycarbonate	20%	100V	D
C56	3pF	Tubular Ceramic	0.5pF	200V	D
C57	0.1uF	Polycarbonate	20%	100V	D
C58	0.047uF	Polycarbonate	20%	100V	D
C59	0.047uF	Polycarbonate	20%	100V	D
C60	12-358pF	Air-spaced variable	-	-	D
C61	20pF	Tubular Ceramic	10%	750V	D
C62	20pF	Tubular Ceramic	10%	750V	D
C63	0.047uF	Polycarbonate	20%	100V	D
C64	0.1uF	Polycarbonate	20%	100V	D
C65	12-358pF	Air-spaced variable	-	-	D
C66	20pF	Tubular Ceramic	10%	750V	D
C67	25pF	Tubular Ceramic	10%	750V	D
C68	50pF	Tubular Ceramic	10%	750V	D
C69	0.1uF	Polycarbonate	20%	100V	D
C70	0.001uF	Silvered Mica	5%	350V	D
C71	0.047uF	Polycarbonate	20%	100V	D
C72	0.047uF	Polycarbonate	20%	100V	D
C73	150pF	Silvered Mica	5%	350V	D
C74	0.1uF	Polycarbonate	20%	100V	D
C75-C76	-	References not allocated	-	-	-
C77	0.047uF	Polycarbonate	20%	100V	D
C78	6pF	Tubular Ceramic (N750)	10%	750V	D
C79	0.1uF	Polycarbonate	20%	100V	D
C80	0.001uF	Silvered Mica	5%	350V	E
C81	15pF	Tubular Ceramic	10%	100V	E
C82	0.001uF	Silvered Mica	5%	350V	E
C83	0.1uF	Polycarbonate	20%	100V	E
C84	0.1uF	Polycarbonate	20%	100V	E
C85	0.1uF	Polycarbonate	20%	100V	E
C86	0.0015uF	Tubular Ceramic	10%	750V	E
C87	0.001uF	Silvered Mica	5%	350V	E
C88	15pF	Tubular Ceramic	10%	100V	E
C89	0.001uF	Silvered Mica	5%	350V	E

Ref	Value	Type	Tolerance	Wkg. V.	Loc
C90	40pF	Tubular Ceramic	10%	750V	E
C91	22pF	Tubular Ceramic	10%	100V	E
C92	0.047uF	Polycarbonate	20%	100V	E
C93	0.001uF	Silvered Mica	5%	350V	E
C94	0.047uF	Polycarbonate	20%	100V	E
C95	0.047uF	Polycarbonate	20%	100V	E
C96	0.1uF	Polycarbonate	20%	100V	E
C97	0.001uF	Silvered Mica	5%	350V	E
C98	100pF	Silvered Mica	5%	350V	E
C99	0.001uF	Silvered Mica	5%	350V	E
C100	0.01uF	Polycarbonate	20%	100V	E
C101	0.1uF	Polycarbonate	20%	100V	E
C102	0.1uF	Polycarbonate	20%	100V	E
C103	8.2pF	Tubular Ceramic	10%	100V	E
C104	0.1uF	Polycarbonate	20%	100V	E
C105	0.001uF	Silvered Mica	5%	350V	E
C106	0.001uF	Tubular Ceramic	10%	750V	E
C107	0.1uF	Polycarbonate	20%	100V	E
C108	0.1uF	Polycarbonate	20%	100V	E
C109	-	Reference not allocated	-	-	-
C110	0.1uF	Polycarbonate	20%	100V	F
C111	0.1uF	Polycarbonate	20%	100V	F
C112	0.1uF	Polycarbonate	20%	100V	F
C113	0.001uF	Disk Ceramic	20%	500V	F
C114	0.0015uF	Tubular Ceramic	10%	750V	F
C115	0.047uF	Polycarbonate	20%	100V	F
C116	0.1uF	Polycarbonate	20%	100V	F
C117	0.01uF	Polycarbonate	20%	100V	F
C118	0.002uF	Silvered Mica	5%	350V	F
C119	0.001uF	Disk Ceramic	20%	500V	F
C120	0.1uF	Polycarbonate	20%	100V	F
C121	0.1uF	Polycarbonate	20%	100V	F
C122	0.01uF	Polycarbonate	20%	100V	F
C123	250pF	Silvered Mica	5%	350V	F
C124	1.5-19.5pF	Tube Trimmer	-	-	F
C125*	15 pF	Silvered Mica	5%	350V	F
C126	0.1uF	Polycarbonate	20%	100V	F
C127	0.1uF	Polycarbonate	20%	100V	F
C128	0.1uF	Polycarbonate	20%	100V	F
C129	50pF	Tubular Ceramic	10%	750V	F
C130	0.047uF	Polycarbonate	20%	100V	F
C131	0.001uF	Tubular Ceramic	10%	750V	F
C132	0.1uF	Polycarbonate	20%	100V	F
C133-C137	-	References not allocated	-	-	-
C138	0.1uF	Polycarbonate	20%	100V	T
C139	0.1uF	Polycarbonate	20%	100V	T

(\*) Value may be adjusted on test.

Ref	Value	Type	Tolerance	Wkg. V.	Loc
C140	10uF	Tubular Electrolytic	+50%-10%	16V	G
C141	110pF	Silvered Mica	5%	350V	G
C142	0.047uF	Polycarbonate	20%	100V	G
C143	2pF	Tubular Ceramic	0.25pF	750V	G
C144	0.001uF	Disk Ceramic	20%	500V	G
C145	110pF	Silvered Mica	5%	350V	G
C146	2pF	Tubular Ceramic	0.25pF	750V	G
C147	-	Reference not allocated	-	-	-
C148	110pF	Silvered Mica	5%	350V	G
C149	0.1uF	Polycarbonate	20%	100V	G
C150	-	Reference not allocated	-	-	-
C151	0.047uF	Polycarbonate	20%	100V	G
C152	0.1uF	Polycarbonate	20%	100V	G
C153	0.047uF	Polycarbonate	20%	100V	G
C154	10-40pF	Disk Ceramic Trimmer	-	-	G
C155*	100pF	Polystyrene	5%	125V	G
C155A	250pF	Polystyrene	5%	125V	G
C156	0.1uF	Polycarbonate	20%	100V	G
C157*	680pF	Polystyrene	2%	125V	G
C158	0.1uF	Polycarbonate	20%	100V	G
C159	150pF	Silvered Mica	5%	350V	G
C160	6pF	Tubular Ceramic	10%	750V	G
C161	0.001uF	Disk Ceramic	20%	500V	G
C162	150pF	Silvered Mica	5%	350V	G
C163	6pF	Tubular Ceramic	10%	750V	G
C164	-	Reference not allocated	-	-	-
C165	0.1uF	Polycarbonate	20%	100V	G
C166	150pF	Silvered Mica	5%	350V	G
C167	-	Reference not allocated	-	-	-
C168	0.047uF	Polycarbonate	20%	100V	G
C169	-	Reference not allocated	-	-	-
C170	22pF	Tubular Ceramic	10%	750V	H
C171	0.1uF	Polycarbonate	20%	100V	H
C172	0.047uF	Polycarbonate	20%	100V	H
C173*	22pF	Tubular Ceramic	10%	750V	H
C174*	60pF	Tubular Ceramic	10%	750V	H
C175*	150pF	Silvered Mica	5%	350V	H
C176	4-29pF	Trimmer	-	-	H
C177	15-150pF	Air-spaced variable	-	-	H
C178	5pF	Silvered Mica	5%	350V	H
C179	0.1uF	Polycarbonate	20%	100V	H
C180/181	0.1uF	Polycarbonate	20%	100V	H
C182 & A	0.001uF	Silvered Mica	5%	350V	H
C183	0.1uF	Polycarbonate	20%	100V	H
C184	0.047uF	Polycarbonate	20%	100V	H
C185	500pF	Silvered Mica	5%	350V	H
C186	0.0018uF	Silvered Mica	5%	350V	H
C187	300pF	Silvered Mica	5%	350V	H
C188	0.0022uF	Silvered Mica	5%	200V	H
C189	200pF	Silvered Mica	5%	350V	H

\* Adjusted on test.

(XV)

For Service Manuals Contact  
**MAURITRON TECHNICAL SERVICES**  
 8 Cherry Tree Rd, Chinnor  
 Oxon OX9 4QY  
 Tel: 01844-351694 Fax: 01844-352554  
 Email: enquiries@maurtron.co.uk

Ref	Value	Type	Tolerance	Wkg. V.	Loc
C190	10uF	Tantalum	+50%-20%	25V	I
C191	0.0012uF	Silvered Mica	1%	350V	I
C192	0.1uF	Polycarbonate	20%	100V	I
C193	0.1uF	Polycarbonate	20%	100V	I
C194	10uF	Tantalum	+50%-20%	25V	I
C195	0.002uF	Silvered Mica	5%	350V	I
C196	10uF	Tantalum	+50%-20%	25V	I
C197	0.1uF	Polycarbonate	20%	100V	I
C198	0.001uF	Disk Ceramic	20%	500V	I
C199	0.1uF	Polycarbonate	20%	100V	I
C200/201	-	References not allocated	-	-	-
C202	0.1uF	Polycarbonate	20%	100V	I
C203	0.1uF	Polycarbonate	20%	100V	I
C204	0.1uF	Polycarbonate	20%	100V	I
C205	0.1uF	Polycarbonate	20%	100V	I
C206	0.1uF	Polycarbonate	20%	100V	I
C206A	200pF	Silvered Mica	2%	350V	I
C207	0.1uF	Polycarbonate	20%	100V	I
C208	3pF	Tubular Ceramic	0.5pF	200V	I
C209	3pF	Tubular Ceramic	0.5pF	200V	I
C210	10uF	Tantalum	+50%-20%	25V	I
C211	-	Reference not allocated	-	-	-
C212	10uF	Tantalum	+50%-20%	25V	I
C213	0.001uF	Tubular Ceramic	10%	750V	I
C214	100pF	Polystyrene	2%	125V	I
C215	-	Reference not allocated	-	-	-
C216	390pF	Polystyrene	5%	125V	I
C217	350pF	Silvered Mica	5%	350V	J
C218	250pF	Silvered Mica	5%	350V	J
C219	0.047uF	Polycarbonate	20%	100V	R
C220	0.047uF	Polycarbonate	20%	100V	J
C221	70pF	Tubular Ceramic	10%	750V	J
C222	300pF	Silvered Mica	5%	350V	J
C223	0.0044uF	Polystyrene	2%	30V	J
C224	400pF	Silvered Mica	5%	350V	J
C225	0.1uF	Polycarbonate	20%	100V	J
C226	15pF	Tubular Ceramic	10%	750V	J
C227	370pF	Silvered Mica	5%	350V	J
C228	300pF	Silvered Mica	5%	350V	J
C229	70pF	Tubular Ceramic	10%	750V	J
C230	30pF	Tubular Ceramic	10%	750V	J
C231	0.0044uF	Polystyrene	2%	30V	J
C232	400pF	Silvered Mica	5%	350V	J
C233	350pF	Silvered Mica	5%	350V	J
C234	15pF	Tubular Ceramic	10%	750V	J
C235	250pF	Silvered Mica	5%	350V	J
C236	70pF	Tubular Ceramic	10%	750V	J
C237	300pF	Silvered Mica	5%	350V	J
C238	30pF	Tubular Ceramic	10%	750V	J
C239	0.0044uF	Polystyrene	2%	30V	J

Ref	Value	Type	Tolerance	Wkg. V.	Loc
C240	400pF	Silvered Mica	5%	350V	J
C241	390pF	Silvered Mica	5%	350V	J
C242	15pF	Tubular Ceramic	10%	750V	J
C243	100pF	Silvered Mica	5%	350V	J
C244	300pF	Silvered Mica	5%	350V	J
C245	20pF	Tubular Ceramic	10%	750V	J
C246	0.0044uF	Polystyrene	2%	30V	J
C247	400pF	Silvered Mica	5%	350V	J
C248	370pF	Silvered Mica	5%	350V	J
C249	15pF	Tubular Ceramic	10%	750V	J
C250	250pF	Silvered Mica	5%	350V	J
C251	30pF	Tubular Ceramic	10%	750V	J
C252	0.0044uF	Polystyrene	2%	30V	J
C253	400pF	Silvered Mica	5%	350V	J
C254	350pF	Silvered Mica	5%	350V	J
C255	10pF	Tubular Ceramic	10%	750V	J
C256	12pF	Tubular Ceramic	10%	750V	J
C257	250pF	Silvered Mica	5%	350V	J
C258	50pF	Tubular Ceramic	10%	750V	J
C259	300pF	Silvered Mica	5%	350V	J
C260	0.001uF	Disk Ceramic	20%	500V	K
C261	0.1uF	Polycarbonate	20%	100V	K
C262	0.047uF	Polycarbonate	20%	100V	K
C263	0.1uF	Polycarbonate	20%	100V	K
C264	0.1uF	Polycarbonate	20%	100V	K
C265	0.001uF	Disk Ceramic	20%	500V	K
C266	0.047uF	Polycarbonate	20%	100V	K
C267	0.1uF	Polycarbonate	20%	100V	K
C268	0.1uF	Polycarbonate	20%	100V	K
C269	0.001uF	Disk Ceramic	20%	500V	K
C270	0.047uF	Polycarbonate	20%	100V	K
C271	0.1uF	Polycarbonate	20%	100V	K
C272	0.001uF	Disk Ceramic	20%	500V	K
C273	540pF	Silvered Mica	5%	350V	K
C274	0.047uF	Polycarbonate	20%	100V	K
C275	0.1uF	Polycarbonate	20%	100V	K
C276	0.001uF	Disk Ceramic	20%	500V	K
C277	0.1uF	Polycarbonate	20%	100V	K
C278	0.1uF	Polycarbonate	20%	100V	K
C279	0.002uF	Silvered Mica	5%	350V	K
C280	0.001uF	Disk Ceramic	20%	500V	K
C281	0.001uF	Disk Ceramic	20%	500V	K
C282	100pF	Silvered Mica	5%	350V	K
C283	0.1uF	Polycarbonate	20%	100V	K
C284	0.001uF	Disk Ceramic	20%	500V	K
C285	0.1uF	Polycarbonate	20%	100V	K
C286	0.002uF	Silvered Mica	5%	350V	K
C287	0.001uF	Disk Ceramic	20%	500V	K
C288	10uF	Tubular Electrolytic	+50%-10%	16V	K
C289	0.1uF	Polycarbonate	20%	100V	K

(XVII)

For Service Manuals Contact  
**MAURITRON TECHNICAL SERVICES**  
8 Cherry Tree Rd, Chinnor  
Oxon OX9 4QY  
Tel: 01844-351694 Fax: 01844-352554  
Email: enquiries@mauritron.co.uk

Ref	Value	Type	Tolerance	Wkg. V.	Loc
C290	0.1uF	Polycarbonate	20%	100V	K
C291	0.1uF	Polycarbonate	20%	100V	K
C292	0.001uF	Tubular Ceramic	20%	750V	K
C293	0.047uF	Polycarbonate	20%	100V	K
C294	0.001uF	Disk Ceramic	20%	500V	K
C295	0.1uF	Polycarbonate	20%	100V	K
C296	0.1uF	Polycarbonate	20%	100V	K
C297	0.1uF	Polycarbonate	20%	100V	K
C298	0.001uF	Disk Ceramic	20%	500V	K
C299	0.002uF	Silvered Mica	5%	350V	K
C300	10uF	Tubular Electrolytic	+50%-10%	16V	K
C301-307	-	References not allocated	-	-	-
C308	10uF	Tantalum	20%	35V	Q
C309	1uF	Tantalum	20%	35V	Q
C310	8.5-126.5pF	Air-spaced variable	-	-	L
C311	8.5-126.5pF	Air-spaced variable	-	-	L
C312	800pF	Silvered Mica	5%	350V	L
C313	50pF	Silvered Mica	5%	350V	L
C314	0.005uF	Metallised Paper	20%	250V	L
C315	0.1uF	Polycarbonate	20%	100V	L
C316	0.1uF	Polycarbonate	20%	100V	L
C317	0.1uF	Polycarbonate	20%	100V	L
C318	0.001uF	Tubular Ceramic	10%	750V	L
C319	10uF	Tubular Electrolytic	+50%-10%	16V	L
C320	0.1uF	Polycarbonate	20%	100V	L
C321	0.005uF	Metallised Paper	20%	250V	L
C322	0.001uF	Disk Ceramic	20%	500V	L
C323	0.001uF	Disk Ceramic	20%	500V	L
C324	10uF	Tubular Electrolytic	+50%-10%	16V	L
C325-329	-	References not allocated	-	-	-
C330	80uF	Tubular Electrolytic	+50%-10%	25V	M
C331	0.01uF	Polycarbonate	20%	100V	M
C332	25uF	Tubular Electrolytic	+50%-10%	25V	M
C333 *	0.005uF	Metallised Paper	20%	250V	M
C334	1uF	Tubular Electrolytic	+100%-10%	40V	M
C335	0.1uF	Polycarbonate	20%	100V	M
C336	80uF	Tubular Electrolytic	+50%-10%	25V	M
C337	0.1uF	Polycarbonate	20%	100V	M
C338	0.1uF	Polycarbonate	20%	100V	M
C339	80uF	Tubular Electrolytic	+50%-10%	25V	M
C340	0.1uF	Polycarbonate	20%	100V	M
C341	10uF	Tubular Electrolytic	+50%-10%	16V	M
C342	10uF	Tubular Electrolytic	+50%-10%	16V	M
C343	0.01uF	Polycarbonate	20%	100V	M
C344	10uF	Tubular Electrolytic	+50%-10%	16V	M
C345	80uF	Tubular Electrolytic	+50%-10%	25V	M
C346	0.1uF	Polycarbonate	20%	100V	M
C347	125uF	Tubular Electrolytic	+50%-10%	16V	M
C348	80uF	Tubular Electrolytic	+50%-10%	25V	S
C349	0.1uF	Polycarbonate	20%	100V	P

(\*) 0.001uF on Model EC958/1

(XVIII)

For Service Manuals Contact  
MAURITRON TECHNICAL SERVICES  
8 Cherry Tree Rd, Chinnor  
Oxon OX9 4QY  
Tel: 01844-351694 Fax: 01844-352554  
Email: enquiries@mauritron.co.uk

Ref	Value	Type	Tolerance	Wkg. V.	Loc
C350	80uF	Tubular Electrolytic	+50%-10%	25V	N
C351	0.047uF	Polycarbonate	20%	100V	N
C352	0.1uF	Polycarbonate	20%	100V	N
C353	0.1uF	Polycarbonate	20%	100V	N
C354	0.1uF	Polycarbonate	20%	100V	N
C355	0.01uF	Polystyrene	1%	125V	N
C356	0.001uF	Silvered Mica	5%	350V	N
C357	0.0047uF	Polystyrene	1%	125V	N
C358	0.001uF	Disk Ceramic	20%	500V	N
C359	0.047uF	Polycarbonate	20%	100V	N
C360	0.047uF	Polycarbonate	20%	100V	N
C361	0.1uF	Polycarbonate	20%	100V	N
C362	0.1uF	Polycarbonate	20%	100V	N
C363	0.1uF	Polycarbonate	20%	100V	N
C364	0.1uF	Polycarbonate	20%	100V	N
C365	0.1uF	Polycarbonate	20%	100V	N
C366-367	-	References not allocated	-	-	-
C368	0.1uF	Polycarbonate	20%	100V	T
C369	0.1uF	Polycarbonate	20%	100V	T
C370	6,400uF	Tubular Electrolytic	+50% -10%	16V	O
C371	6,400uF	Tubular Electrolytic	+50% -10%	16V	O
C372	6,400uF	Tubular Electrolytic	+50% -10%	25V	O
C373	1,000uF	Tubular Electrolytic	+100% -20%	16V	O
C374	1,000uF	Tubular Electrolytic	+100% -20%	16V	O
C375	0.005uF	Disk Ceramic	+80% -20%	3000V	O
C376	0.047uF	Paper	10%	400V	S
C377	0.047uF	Paper	10%	400V	S
C378-379	-	Refs not allocated	-	-	-
C380-497	-	Refs allocated to Turret Disks (see Page XXIV)			
FC1	1500pF	Filtercon Type 1201-077 (Erie)	-	200V	D

## Resistors

Ref	Value	Tol	Rtg	Loc	Ref	Value	Tol	Rtg	Loc
R1	1,000 ohms	5%	0.1 W	A	R50	22 ohms	5%	0.1 W	D
R2	1,000 ohms	5%	0.1 W	A	R51	220 ohms	5%	0.1 W	D
R3	1,500 ohms	5%	0.1 W	A	R52	22 ohms	5%	0.1 W	D
R4	1,800 ohms	5%	0.1 W	A	R53	0.22 Megohm	5%	0.1 W	D
R5-					R54	0.22 Megohm	5%	0.1 W	D
R9	Not allocated	-	-	-	R55	0.1 Megohm	5%	0.1 W	D
R10	1,000 ohms	5%	0.5 W	S	R56	330 ohms	5%	0.1 W	D
R11	39 ohms	5%	0.1 W	B	R57	0.22 Megohm	5%	0.1 W	D
R12	39 ohms	5%	0.1 W	B	R58	100 ohms	5%	0.1 W	D
R13	47 ohms	5%	0.1 W	B	R59	270 ohms	5%	0.1 W	D
R14	68 ohms	5%	0.1 W	B	R60	820 ohms	5%	0.1 W	D
R15	68 ohms	5%	0.1 W	B	R61	0.1 Megohm	5%	0.1 W	D
R16	18 ohms	5%	0.1 W	B	R62	330 ohms	5%	0.1 W	D
R17-					R63	22 ohms	5%	0.1 W	D
R19	Not allocated	-	-	-	R64	220 ohms	5%	0.1 W	D
R20	6,800 ohms	5%	0.1 W	R	R65	0.1 Megohm	5%	0.1 W	D
R21	100 ohms	5%	0.1 W	R	R66	470 ohms	5%	0.1 W	D
R22	1,000 ohms	5%	0.1 W	R	R67	470 ohms	5%	0.1 W	D
R23	22,000 ohms	5%	0.1 W	R	R68	10,000 ohms	5%	0.1 W	D
R24-					R69	150 ohms	5%	0.1 W	D
R29	Not allocated	-	-	-	R70	22 ohms	5%	0.1 W	D
R30	47,000 ohms	5%	0.1 W	C	R71-				
R31	1.8 Megohm	10%	0.05W	C	R78	Not allocated	-	-	-
R32	47,000 ohms	5%	0.1 W	C	R79	47 ohms	5%	0.1 W	D
R33	1.8 Megohm	10%	0.05W	C	R80	220 ohms	5%	0.1 W	E
R34	0.1 Megohm	5%	0.1 W	C	R81	47,000 ohms	5%	0.1 W	E
R35	47,000 ohms	5%	0.1 W	C	R82	47,000 ohms	5%	0.1 W	E
R36	1.8 Megohm	10%	0.05W	C	R83	0.1 Megohm	5%	0.1 W	E
R37-					R84	2,200 ohms	5%	0.1 W	E
R39	Not allocated	-	-	-	R85	4,700 ohms	5%	0.1 W	E
R40	1.8 Megohm	10%	0.05W	D	R86	1,200 ohms	5%	0.1 W	E
R41	270 ohms	5%	0.1 W	D	R87	1,000 ohms	5%	0.1 W	E
R42	0.1 Megohm	5%	0.1 W	D	R88	1,000 ohms	5%	0.1 W	E
R43	22 ohms	5%	0.1 W	D	R89	100 ohms	5%	0.1 W	E
R44	180 ohms	5%	0.1 W	D	R90	68,000 ohms	5%	0.1 W	E
R45	1 Megohm	5%	0.1 W	D	R91	0.12 Megohm	5%	0.1 W	E
R46	33,000 ohms	5%	0.1 W	D	R92	68,000 ohms	5%	0.1 W	E
R47	270 ohms	5%	0.1 W	D	R93	3,900 ohms	5%	0.1 W	E
R48	0.47 Megohm	5%	0.1 W	D	R94	22,000 ohms	5%	0.1 W	E
R49	4,700 ohms	5%	0.1 W	D	R95	22 ohms	5%	0.1 W	E
					R96-				
					R97	Not allocated	-	-	-
					R98	4.7 ohms w.w.*	5%	5W	F
					R99	150 ohms	10%	0.5W	R

(\* ) R98 is fitted only on late receivers equipped with 1MHz Oven 7503P.  
Refer to Note on page XXVIII.

(XX)

For Service Manuals Contact  
MAURITRON TECHNICAL SERVICES  
8 Cherry Tree Rd, Chinnor  
Oxon OX9 4QY  
Tel: 01844-351694 Fax: 01844-352554  
Email: enquiries@mauritron.co.uk

Ref	Value	Tol	Rtg	Loc	Ref	Value	Tol	Rtg	Loc
R100	47 ohms	5%	0.1 W	F	R150	22 ohms	5%	0.1 W	H
R101	100 ohms	5%	0.1 W	F	R151	22,000 ohms	5%	0.1 W	H
R102	47,000 ohms	5%	0.1 W	F	R152	47,000 ohms	5%	0.1 W	H
R103	27,000 ohms	5%	0.1 W	F	R153	680 ohms	5%	0.1 W	H
R104	470 ohms	5%	0.1 W	F	R154	68 ohms	5%	0.1 W	H
R105	100 ohms	5%	0.1 W	F	R155	150 ohms	5%	0.1 W	H
R106	3,300 ohms	5%	0.1 W	F	R156				
R107	0.22 Megohm	5%	0.1 W	F	-159	Not allocated	-	-	-
R108	0.12 Megohm	5%	0.1 W	F	R160	220 ohms	5%	0.1 W	I
R109	150 ohms	5%	0.1 W	F	R161	2,200 ohms	5%	0.1 W	I
R110	150 ohms	5%	0.1 W	F	R162	1,000 ohms	5%	0.1 W	I
R111	47,000 ohms	5%	0.1 W	F	R163	1,000 ohms	5%	0.1 W	I
R112	3,900 ohms	5%	0.1 W	F	R164	39,000 ohms	5%	0.1 W	I
R113	330 ohms	5%	0.1 W	F	R164A	22,000 ohms	5%	0.1 W	I
R114	100 ohms	5%	0.1 W	F	R165	220 ohms	5%	0.1 W	I
R115					R166	1,200 ohms	5%	0.1 W	I
-118	Not allocated	-	-	-	R167	150 ohms	5%	0.1 W	I
R119*	680 ohms	5%	0.1 W	R	R167A	1,000 ohms	5%	0.1 W	I
R120	220 ohms	5%	0.1 W	G	R168	4,700 ohms	5%	0.1 W	I
R120A	0.27 Megohm	5%	0.1 W	G	R168A	0.12 Megohm	5%	0.1 W	I
R121	0.39 Megohm	5%	0.1 W	G	R169	12,000 ohms	5%	0.1 W	I
R122	0.39 Megohm	5%	0.1 W	G	R170	0.1 Megohm	5%	0.1 W	I
R123	0.39 Megohm	5%	0.1 W	G	R170A	220 ohms	5%	0.1 W	I
R124	0.47 Megohm	5%	0.1 W	G	R171	22,000 ohms	5%	0.1 W	I
R125	47,000 ohms	5%	0.1 W	G	R171A	22,000 ohms	5%	0.1 W	I
R126	0.68 Megohm	5%	0.1 W	G	R172	1,000 ohms	5%	0.1 W	I
R127	2,700 ohms	5%	0.1 W	G	R172A	1,000 ohms	5%	0.1 W	I
R128	470 ohms	5%	0.1 W	-G	R173	100 ohms	5%	0.1 W	I
R129	220 ohms	5%	0.1 W	G	R174	0.27 Megohm	5%	0.1 W	I
R130	680 ohms	5%	0.1 W	G	R175	560 ohms	5%	0.1 W	I
R131					R176	150 ohms	5%	0.1 W	I
-133	Not allocated	-	-	-	R177	1,000 ohms	5%	0.1 W	I
R134	0.39 Megohm	5%	0.1 W	G	R178	22,000 ohms	5%	0.1 W	I
R134A	0.27 Megohm	5%	0.1 W	G	R179	2,200 ohms	5%	0.1 W	Q
R135	0.39 Megohm	5%	0.1 W	G	R180	82,000 ohms	5%	0.1 W	J
R136	0.39 Megohm	5%	0.1 W	G	R181	22,000 ohms	5%	0.1 W	J
R137	10,000 ohms	5%	0.1 W	G	R182	220 ohms	5%	0.1 W	J
R138	10,000 ohms	5%	0.1 W	G	R183	82,000 ohms	5%	0.1 W	J
R139	4,700 ohms	5%	0.1 W	R	R184	10,000 ohms	5%	0.1 W	J
R140	10,000 ohms	5%	0.1 W	H	R185	82,000 ohms	5%	0.1 W	J
R141	0.47 Megohm	5%	0.1 W	H	R186	10,000 ohms	5%	0.1 W	J
R142	47,000 ohms	5%	0.1 W	H	R187	Not allocated	-	-	-
R143	680 ohms	5%	0.1 W	H	R188	22,000 ohms	5%	0.1 W	J
R144	180 ohms	5%	0.1 W	H	R189	82,000 ohms	5%	0.1 W	J
R145	120 ohms	5%	0.1 W	H	R190	10,000 ohms	5%	0.1 W	J
R146	22,000 ohms	5%	0.1 W	H	R191				
R147	47,000 ohms	5%	0.1 W	H	-197	Not allocated	-	-	-
R148	470 ohms	5%	0.1 W	H	R198	1,000 ohms	5%	0.1 W	T
R149	68 ohms	5%	0.1 W	H	R199	1,000 ohms	5%	0.1 W	T

(\*) Subject to adjustment on test.

(XXI)

For Service Manuals Contact  
**MAURITRON TECHNICAL SERVICES**  
8 Cherry Tree Rd, Chinnor  
Oxon OX9 4QY  
Tel:- 01844-351694 Fax:- 01844-352554  
Email:- enquiries@mauritron.co.uk

Ref	Value	Tol	Rtg	Loc
R200	0.27 Megohm	5%	0.1 W	K
R201	1,000 ohms	5%	0.1 W	K
R202	5,600 ohms	5%	0.1 W	K
R203	330 ohms	5%	0.1 W	K
R204	0.27 Megohm	5%	0.1 W	K
R205	1,000 ohms	5%	0.1 W	K
R206	1,200 ohms	5%	0.1 W	K
R207	330 ohms	5%	0.1 W	K
R208	0.27 Megohm	5%	0.1 W	K
R209	1,000 ohms	5%	0.1 W	K
R210	5,600 ohms	5%	0.1 W	K
R211	330 ohms	5%	0.1 W	K
R212	0.1 Megohm	5%	0.1 W	K
R213	1,000 ohms	5%	0.1 W	K
R214	8,200 ohms	5%	0.1 W	K
R215	330 ohms	5%	0.1 W	K
R216	47,000 ohms	5%	0.1 W	K
R217	22,000 ohms	5%	0.1 W	K
R218	100 ohms	5%	0.1 W	K
R219	22,000 ohms	5%	0.1 W	K
R220	33,000 ohms	5%	0.1 W	K
R221	47 ohms	5%	0.1 W	K
R222	270 ohms	5%	0.1 W	K
R223	0.47 Megohm	5%	0.1 W	K
R224	Not allocated	-	-	-
R225	1,000 ohms	5%	0.1 W	K
R226	47,000 ohms	5%	0.1 W	K
R227	22,000 ohms	5%	0.1 W	K
R228	100 ohms	5%	0.1 W	K
R229	0.27 Megohm	5%	0.1 W	K
R230	10,000 ohms	5%	0.1 W	K
R231	2,200 ohms	5%	0.1 W	K
R232	47,000 ohms	5%	0.1 W	K
R233	0.27 Megohm	5%	0.1 W	K
R234	1,000 ohms	5%	0.1 W	K
R235	1,500 ohms	5%	0.1 W	K
R236	47,000 ohms	5%	0.1 W	K
R237	22,000 ohms	5%	0.1 W	K
R238	100 ohms	5%	0.1 W	K
R239	10,000 ohms	5%	0.1 W	K
R240	3,300 ohms	5%	0.1 W	K
R241	1 Megohm	5%	0.1 W	K
R242	22,000 ohms	5%	0.1 W	K
R243	330 ohms	5%	0.1 W	K
R244	150 ohms	5%	0.1 W	K
R245				
-247	Not allocated	-	-	-
R248	47,000 ohms	5%	0.1 W	Q
R249	0.1 Megohm	5%	0.1 W	Q

Ref	Value	Tol	Rtg	Loc
R250	680 ohms	5%	0.1 W	L
R251	0.27 Megohm	5%	0.1 W	L
R252	10,000 ohms	5%	0.1 W	L
R253	330 ohms	5%	0.1 W	L
R254	2,200 ohms	5%	0.1 W	L
R255	6,800 ohms	5%	0.1 W	L
R256	22,000 ohms	5%	0.1 W	L
R257	2,200 ohms	5%	0.1 W	L
R258	1,000 ohms	5%	0.1 W	L
R259*	4,700 ohms	5%	0.1 W	L
R260	1,000 ohms	5%	0.1 W	L
R261	33,000 ohms	5%	0.1 W	L
R262	2,700 ohms	5%	0.1 W	L
R263	100 ohms	5%	0.1 W	L
R264				
-269	Not allocated	-	-	-
R270	1 Megohm	5%	0.1 W	M
R271	0.1 Megohm	5%	0.1 W	M
R272	39 ohms	5%	0.1 W	M
R273	10,000 ohms	5%	0.1 W	M
R274	82,000 ohms	5%	0.1 W	M
R275	10,000 ohms	5%	0.1 W	M
R276	150 ohms	5%	0.1 W	M
R277	47,000 ohms	5%	0.1 W	M
R278	8,200 ohms	5%	0.1 W	M
R279	150 ohms	5%	0.1 W	M
R280	33,000 ohms	5%	0.1 W	M
R281	0.1 Megohm	5%	0.1 W	M
R282	0.47 Megohm	5%	0.1 W	M
R283	47,000 ohms	5%	0.1 W	M
R284	47 ohms	5%	0.1 W	M
R285	220 ohms	5%	0.1 W	M
R286	4,700 ohms	5%	0.1 W	M
R287	3,300 ohms	5%	0.1 W	M
R288	150 ohms	5%	0.1 W	M
R289	10,000 ohms	5%	0.1 W	M
R290	1,500 ohms	5%	0.1 W	M
R291	100 ohms	5%	0.1 W	M
R292	1 Megohm	5%	0.1 W	M
R293	33 ohms	5%	0.1 W	M
R294	100 ohms	5%	0.1 W	M
R295	Not allocated	-	-	-
R296	470 ohms	10%	0.5 W	S
R297	100 ohms	5%	0.5 W	S
R298	2.2 ohms w. w.	5%	2.5 W	S
R299	12 ohms	10%	0.5 W	Q

(\*) Value may be adjusted on test.

(XXII)

For Service Manuals Contact  
MAURITRON TECHNICAL SERVICES  
8 Cherry Tree Rd, Chinnor  
Oxon OX9 4QY  
Tel:- 01844-351694 Fax:- 01844-352554  
Email:- enquiries@mauritron.co.uk

Ref	Value	Tol	Rtg	Loc	Ref	Value	Tol	Rtg	Loc
R300	3,300 ohms	5%	0.1 W	Q	R320	1,200 ohms	5%	0.1 W	N
R301	1 Megohm	5%	0.1 W	P	R321	4,700 ohms	5%	0.1 W	N
R302	1,000 ohms	5%	0.1 W	P	R322	6,800 ohms	5%	0.1 W	N
R303	1,000 ohms	5%	0.1 W	Q	R323	6,800 ohms	5%	0.1 W	N
R304	100 ohms	5%	0.1 W	P	R324	4,700 ohms	5%	0.1 W	N
R305	560 ohms	5%	0.1 W	P	R325	10,000 ohms	5%	0.1 W	N
R306	10,000 ohms	5%	0.1 W	P	R326	10,000 ohms	5%	0.1 W	N
R307					R327				
-308	Not allocated	-	-	-	-328	Not allocated	-	-	-
R309	2.2 Megohms	10%	0.05 W	Q	R329	1,800 ohms	5%	12W	T
R310	100 ohms	5%	0.5 W	N	R330	5 ohms w.w.	5%	6W	O
R311	68 ohms	5%	0.1 W	N	R331	5 ohms w.w.	5%	9W	O
R312	68 ohms	5%	0.1 W	N	R332	100 ohms w.w.	5%	6W	O
R313	33,000 ohms	5%	0.1 W	N	R333	1.2 ohms w.w.	10%	1W	Q
R314	33,000 ohms	5%	0.1 W	N	R334				
R315	33,000 ohms	5%	0.1 W	N	-349	Not allocated	-	-	-
R316	0.47 Megohm	5%	0.1 W	N	R350				
R317	2,200 ohms	5%	0.1 W	N	-380	References			
R318	15,000 ohms	5%	0.1 W	N		allocated to			
R319	1,000 ohms	5%	0.1 W	N		Turret Disks			
						(See Page			
						XXVII)			

Potentiometers

Ref	Value	Law	Type	Function	Loc
RV1	20,000 ohms	Lin.	Carbon	Peak-RF/Aerial Trimmer	Q
RV2	2,200 ohms	Lin.	Carbon pre-set	AFC Adjuster	P
RV3	10,000 ohms	Lin.	Carbon	V.V.C. Control (Tunable IF)	R
RV4	10,000 ohms	Lin.	Carbon pre-set	V.V.C. Tracker (Tunable IF)	P
RV5	50,000 ohms	Log.	Carbon	IF Gain	Q
RV6	0.47 Megohm	Lin.	Carbon pre-set	Line Level	Q
RV7	0.5 Megohm	Log.	Carbon	AF Gain	Q
RV8	1,000 ohms	Lin.	Carbon pre-set	TR38 Adjuster	S
RV9	3,300 ohms	Lin.	Carbon pre-set	FSK CZ Set	P
RV10	4,700 ohms	Lin.	Carbon pre-set	AF Zero Set	P
RV11	1,000 ohms	Lin.	Carbon pre-set	RF Zero Set	P
RV12	0.47 Megohm	Lin.	Carbon pre-set	AF Calib.	P
RV13	2,700 ohms	Lin.	Carbon pre-set	FSK	N
RV14	10,000 ohms	Lin.	Carbon pre-set	FSK Relay Bias Adj.	N
RV15	10 ohms	Lin.	Wirewound	Dial Dimmer	Q
RV16	1,000 ohms	Lin.	Carbon pre-set	Harmonic Drive Adj.	F
RV17	10,000 ohms	Lin.	Carbon pre-set	INC CAL	Q
RV18	47,000 ohms	Lin.	Carbon pre-set	Fine IF Trim	R

APPENDIX "D"

LIST OF COMPONENT VALUES, TOLERANCES AND RATINGS

PART 2 :: TURRET DISKS

Capacitors

Turret Disk "A" (Aerial)

Ref	Value	Type	Tolerance	Wkg. V.	Range
C380	7-35pF	Ceramic Trimmer	-	-	1
C381	250pF	Silvered Mica	1%	350V	1
C382	70pF	Tubular Ceramic	10%	750V	1
C383	7-35pF	Ceramic Trimmer	-	-	2
C384	800pF	Silvered Mica	1%	350V	2
C385	20pF	Tubular Ceramic	10%	750V	2
C386	4.5-20pF	Ceramic Trimmer	-	-	3
C387	4.5-20pF	Ceramic Trimmer	-	-	4
C388	0.0016uF	Silvered Mica	5%	350V	4
C389	0.0019uF	Silvered Mica	5%	350V	4
C390	0.0024uF	Silvered Mica	5%	350V	4
C391	0.0017uF	Silvered Mica	5%	350V	4
C392	0.0094uF	Silvered Mica	5%	125V	5, 6, 8
C393	0.022uF	Silvered Mica	2%	125V	7
C394	-	-	-	-	-
-399	-	References not allocated	-	-	-

Turret Disk "B" (RF)

Ref	Value	Type	Tolerance	Wkg. V.	Range
C400	6-30pF	Ceramic Trimmer	-	-	1
C401	50pF	Tubular Ceramic	10%	750V	1
C402	250pF	Silvered Mica	1%	350V	1
C403	800pF	Silvered Mica	1%	350V	2
C404	6-30pF	Ceramic Trimmer	-	-	2
C405	4.5-20pF	Ceramic Trimmer	-	-	3
C406	4.5-20pF	Ceramic Trimmer	-	-	4
C407	6-30pF	Ceramic Trimmer	-	-	5
C408	6-30pF	Ceramic Trimmer	-	-	6
C409	6-30pF	Ceramic Trimmer	-	-	7
C410	6-30pF	Ceramic Trimmer	-	-	8
C411	6-30pF	Ceramic Trimmer	-	-	9
C412	6-30pF	Ceramic Trimmer	-	-	10
C413	-	-	-	-	-
-419	-	References not allocated	-	-	-

Turret Disk "C" (Signal Mixer)

Ref	Value	Type	Tolerance	Wkg. V.	Range
C420	6-30pF	Ceramic Trimmer	-	-	1
C421	50pF	Tubular Ceramic	10%	750V	1
C422	250pF	Silvered Mica	1%	350V	1
C423	800pF	Silvered Mica	1%	350V	2
C424	6-30pF	Ceramic Trimmer	-	-	2
C425	4.5-20pF	Ceramic Trimmer	-	-	3
C426	4.5-20pF	Ceramic Trimmer	-	-	4
C427	6-30pF	Ceramic Trimmer	-	-	5
C428	6-30pF	Ceramic Trimmer	-	-	6
C429	6-30pF	Ceramic Trimmer	-	-	7
C430	0.01uF	Polycarbonate	20%	100V	7
C431	0.001uF	Disk Ceramic	20%	500V	7
C432	6-30pF	Ceramic Trimmer	-	-	8
C433	6-30pF	Ceramic Trimmer	-	-	9
C434	0.01uF	Polycarbonate	20%	100V	9
C435	0.001uF	Disk Ceramic	20%	500V	9
C436	0.01uF	Metallised Paper	20%	200V	10
C437	0.047uF	Polycarbonate	20%	100V	10
C438	6-30pF	Ceramic Trimmer	-	-	10
C439	-	-	-	-	-
-449	-	References not allocated	-	-	-

Turret Disk "D" (Main Tune Oscillator)

Ref	Value	Type	Tolerance	Wkg. V.	Range
C450	40pF	Tubular Ceramic	10%	750V	1
C451	4.5-20pF	Ceramic Trimmer	-	-	1
C452	225pF	Silvered Mica	1%	350V	1
C453	4.5-20pF	Ceramic Trimmer	-	-	2
C454	600pF	Silvered Mica	1%	350V	2
C455	0.0012uF	Silvered Mica	1%	350V	3
C456	4.5-20pF	Ceramic Trimmer	-	-	3
C457	4.5-20pF	Ceramic Trimmer	-	-	4
C458	540pF	Silvered Mica	1%	350V	4
C459	15pF	Tubular Ceramic	10%	750V	5
C460	0.0016uF	Silvered Mica	1%	350V	5
C461	4.5-20pF	Ceramic Trimmer	-	-	5
C462	4.5-20pF	Ceramic Trimmer	-	-	6
C463	680pF	Silvered Mica	1%	350V	6
C464	20pF	Tubular Ceramic	10%	750V	6
C465	20pF	Tubular Ceramic	10%	750V	7
C466	470pF	Silvered Mica	1%	350V	7
C467	4.5-20pF	Ceramic Trimmer	-	-	7
C468	4.5-20pF	Ceramic Trimmer	-	-	8
C469	100pF	Silvered Mica	1%	350V	8

(XXV)

For Service Manuals Contact  
 MAURITRON TECHNICAL SERVICES  
 8 Cherry Tree Rd, Chinnor  
 Oxon OX9 4QY  
 Tel:- 01844-351694 Fax:- 01844-352554  
 Email:- enquiries@mauritron.co.uk

Turret Disk "D" (contd.)

Ref	Value	Type	Tolerance	Wkg. V.	Range
C470	30pF	Tubular Ceramic	10%	750V	8
C471	170pF	Silvered Mica	1%	350V	9
C472	4.5-20pF	Ceramic Trimmer	-	-	9
C473	4.5-20pF	Ceramic Trimmer	-	-	10
C474	100pF	Silvered Mica	1%	350V	10
C475	50pF	Tubular Ceramic	10%	750V	10
C476	30pF	Tubular Ceramic	10%	750V	9
C477-479	-	References not allocated			

Turret Disk "E" (Loop Mixer)

Ref	Value	Type	Tolerance	Wkg. V.	Range
C480	6-30pF	Ceramic Trimmer	-	-	1
C481	50pF	Tubular Ceramic	10%	750V	1
C482	240pF	Silvered Mica	1%	350V	1
C483	800pF	Silvered Mica	1%	350V	2
C484	6-30pF	Ceramic Trimmer	-	-	2
C485	6-30pF	Ceramic Trimmer	-	-	3
C486	0.0032uF	Silvered Mica	1%	200V	4
C487	6-30pF	Ceramic Trimmer	-	-	4
C488 -489	-	References not allocated			

Turret Disk "F" (Harmonic Amplifier)

Ref	Value	Type	Tolerance	Wkg. V.	Range
C490	6-30pF	Ceramic Trimmer	-	-	1
C491	50pF	Tubular Ceramic	10%	750V	1
C492	240pF	Silvered Mica	1%	350V	1
C493	800pF	Silvered Mica	1%	350V	2
C494	6-30pF	Ceramic Trimmer	-	-	2
C495	6-30pF	Ceramic Trimmer	-	-	3
C496	0.0032uF	Silvered Mica	1%	200V	4
C497	6-30pF	Ceramic Trimmer	-	-	4

For Service Manuals Contact  
**MAURITRON TECHNICAL SERVICES**  
 8 Cherry Tree Rd, Chinnor  
 Oxon OX9 4QY  
 Tel:- 01844-351694 Fax:- 01844-352554  
 Email:- enquiries@mauritron.co.uk

Resistors

Turret Disk "A" (Aerial)

Ref	Value	Tol	Rtg	Range
R350	0.1 Megohm	5%	0.1 W	1
R351	0.1 Megohm	5%	0.1 W	2
R352	Not allocated			
-359				

Turret Disk "C" (Signal Mixer)

Ref	Value	Tol	Rtg	Range
R370	0.1 Megohm	5%	0.1 W	1
R371	0.1 Megohm	5%	0.1 W	2
R372	0.1 Megohm	5%	0.1 W	7
R373	2,200 ohms	5%	0.1 W	7
R374	0.1 Megohm	5%	0.1 W	9
R375	2,200 ohms	5%	0.1 W	9
R376	2,200 ohms	5%	0.1 W	10
R377	0.1 Megohm	5%	0.1 W	10
R378	Not allocated	-	-	-
R379	Not allocated	-	-	-

Turret Disk "B" (RF)

Ref	Value	Tol	Rtg	Range
R360	0.1 Megohm	5%	0.1 W	1
R361	0.1 Megohm	5%	0.1 W	2
R362	Not allocated			
-369				

Turret Disk "F" (Harmonic Amplifier)

Ref	Value	Tol	Rtg	Range
R380	1,000 ohms	5%	0.1 W	3

(XXVII)

For Service Manuals Contact  
**MAURITRON TECHNICAL SERVICES**  
 8 Cherry Tree Rd, Chinnor  
 Oxon OX9 4QY  
 Tel: 01844-351694 Fax: 01844-352554  
 Email: enquiries@mauritron.co.uk

APPENDIX "E"

SPARES LIST FOR EC958 RECEIVER

The following list details all major spares for the EC958 Receiver. Spares should be ordered by quoting the Circuit Ref. (where applicable), the written description given in the list and the Part No. in the right-hand column. All orders and enquiries should be directed to the address below, quoting the Serial No. of the receiver in all communications.

EDDYSTONE RADIO LIMITED, Telephone : 021-475 2231  
 SALES & SERVICE DEPT., Telex : 337081  
 ALVECHURCH ROAD, Cables : EDDYSTONE, Birmingham  
 BIRMINGHAM B31 3PP, ENGLAND.

Ref	Description	Part No.	
PART NOS FOR EC958/1 RECEIVER - Audio Amplifier Module : LP3053/1. Aerial Atten. Unit : LP3260/1. Master Osc. Unit (complete) : LP3045/2A. SSB Filter : 8415P. Carrier AGC Module : LP3268	<u>MODULES, UNITS AND ASSEMBLIES</u>		
	RF Assembly. (Less Crystal Calibrator, Peak-RF Board, AFC Board and Turret Disks)	D4080	
	935kHz Loop Amplifier Module	LP3055A	
	Tunable IF Module	LP3057A	
	250kHz IF Module	LP3061D	
	100kHz IF Amplifier Module	LP3056	
	Audio Amplifier Module	LP3053	
	FSK Module. (Not fitted in standard receiver)	LP3058	
	Aerial Attenuator Unit	LP3052/1	
	Master Oscillator Unit (complete)	LP3045A	
	1MHz Crystal Oscillator (G.E.C. Type QC.1013YX)	8473P	
	Incremental Oscillator Unit	LP3050	
	100kHz IF Filter Unit	LP3047A	
	CW/SSB Detector & BFO Unit	LP3054	
	Crystal Calibrator Board	LP3059	
	Peak-RF Board	LP3065	
	Meter Board	LP3066	
	SSB Filter (G.E.C. Type QC1170D)	7605PA	
	3-ohm Output Stage	LP3067	
	AFC Board	LP3081	
	250kHz IF Filter	8331P	
	<u>TURRET DISKS AND CONTACT BLOCKS</u>		
	"A"	Aerial Disk	LP3068
	"B"	RF Disk	LP3069
	"C"	1st Signal Mixer Disk	LP3070
	"D"	Main-Tune Oscillator Disk	LP3071
	"E"	1st Loop Mixer Disk	LP3072
	"F"	Harmonic Amplifier Disk	LP3080
	Contact Blocks (4-contact type)	D4082	
	(5-contact type)	D4083	

For Service Manuals Contact  
 MAURITRON TECHNICAL SERVICES  
 8 Cherry Tree Rd, Chinnor  
 Oxon OX9 4QY  
 Tel:- 01844-351694 Fax:- 01844-352554  
 Email:- enquiries@mauritron.co.uk

NOTE: Late EC958 Receivers equipped with 1MHz Crystal Oscillator 7503P (GEC Type No. 1013TX/935A) have a 4.7Ω resistor (R98) in series with the lead to Pin 78 of Master Oscillator Unit. R98 must be shorted out if a replacement 1MHz Crystal Oscillator 8473P (GEC Type No. QC.1013YX) is fitted. R98 is omitted on current

Ref	Description	Part No.
<u>SWITCHES</u>		
S1	CALIBRATOR SWITCH. Miniature push-button	6726P
S2	AERIAL ATTENUATOR SWITCH. 3-pole, 3-position miniature lever switch	7491P
S3	RANGE SWITCH (Wafers S3A-S3E). 5, 10-posn wafers supplied as complete assembly	D4084
S4	NORMAL/SYNTH SWITCH. Miniature toggle	7352P
S5	HIGH-STAB/CONT TUNE SWITCH. 3-pole, 3-position miniature lever switch - special dolly	7490P
S6	NORMAL/SLAVE SWITCH. Miniature toggle	7352P
S7	USB/LSB SWITCH. Miniature toggle	7352P
S8	SELECTIVITY SWITCH. Part of 100kHz IF Filter Unit. Wafers S8A/B & S8E (2-pole 5-way) Wafers S8C/D & S8F/G (2-pole 5-way) Clicker mechanism for S8	8537P 8538P 8536P
S9	MANUAL/AGC SWITCH. Miniature toggle	7352P
S10	SIGNAL MODE SWITCH. 3-pole, 3-position miniature lever switch	7491P
S11	SPEAKER SWITCH. Miniature toggle	7352P
S12	METER SWITCH. 3-pole, 3-position miniature lever switch	7491P
S13	SUPPLY SWITCH. Miniature toggle	7352P
<u>POTENTIOMETERS</u>		
RV1	PEAK-RF/AE TRIM. 20,000 ohms carbon, linear law	7761P
RV2	AFC ADJ. 2,200 ohms carbon pre-set, linear law	8701P
RV3	TUNABLE IF TUNE. 10,000 ohms carbon, linear law	7762P
RV4	TUNABLE IF TRIM. 10,000 ohms carbon pre-set, linear law	6840P
RV5	IF GAIN. 50,000 ohms carbon, logarithmic law	4103/1P
RV6	LINE LEVEL. 0.47 Megohm carbon pre-set, linear law	6077P
RV7	AF GAIN. 0.5 Megohm carbon, logarithmic law	4103P
RV8	TR38 ADJ. 1,000 ohms carbon pre-set, linear law	6076P
RV9	FSK CZ SET. 3,300 ohms carbon pre-set, linear law	7850P
RV10	AF ZERO SET. 4,700 ohms carbon pre-set, linear law	6844P
RV11	RF ZERO SET. 1,000 ohms carbon pre-set, linear law	6076P
RV12	AF CALIB. 0.47 Megohm carbon pre-set, linear law	6077P
RV13	FSK ADJ. 2,700 ohms carbon pre-set, linear law	6841P
RV14	FSK RELAY BIAS ADJ. 10,000 ohms carbon pre-set, linear law	6840P
RV15	DIAL DIMMER. 10 ohms wire-wound pre-set, linear law	7763P
RV16	HARM. DRIVE ADJ. 1,000 ohms carbon pre-set, linear law	6076P
RV17	INC CAL. 10,000 ohms carbon pre-set, linear law	6840P
RV18	FINE IF TRIM. 47,000 ohms carbon pre-set, linear law	6488P
<u>VARIABLE CAPACITORS AND TRIMMERS</u>		
C30/31/37	Gang Assembly. 3 x 12 - 358pF	7379P
C46/60/65	Gang Assembly. 2 x 12 - 358pF + 1 x 18 - 364pF	7357P
C124	Trimmer. 1.5 - 19.5pF	7767P
C176	Trimmer. 4 - 29pF Concentric	6597P
C177	Gang Assembly. 1 x 15-150pF	LP3079
C310/311	Gang Assembly. 2 x 8.5 - 126.5pF	D3363D

Ref	Description	Part No.
	<u>PLUGS AND SOCKETS ETC.</u>	
	Inter-Unit Coaxial Connectors as fitted on coaxial leads coded "E", "H1", "H2", "J", "K", "L", "M", "P" & "U".	
	Male component	7768P
	Female component	7769P
	<u>NB</u> Specify cable letter code so that connector can be supplied ready crimped to suitable length of lead.	
	Standard BNC bayonet-lock coaxial sockets (as used for Aerial Input (Low-Z), IF Out, Ext. Osc. Drive	7225P
	Ditto - plugs (free component)	8012P
PL/A	15-way Drive Assembly Connector (male - free)	7772P
PL/B	37-way Panel Connector (male - free)	7774P
PL/C	15-way Ancillaries Connector (male - fixed)	7772P
SK/A	15-way Drive Assembly Connector (female - fixed)	7770P
SK/B	37-way Panel Connector (female - fixed)	7773P
SK/C	15-way Ancillaries Connector (female - free)	7771P
	"Amp" pin - fixed (as used for module connections etc.)	7775P
	"Amp" socket - free (                      -do-                      )	7776P
	Miniature B/L coaxial plug*	7293P
	Miniature B/L coaxial socket*	7292P
	(*) As used for connections to 100kHz Filter etc.	
	Mains input connector (chassis-mounted component)	D2310/1
	Mains input connector (with 6' x 3-core lead)	D2311/1
	Octal socket (as used for MO 1MHz Crystal Oscillator)	6689P
	Telephone plug	6567P
	Standard push-terminals as used for High-Z Aerial Input	6102P
	Earth terminal	6371P
JK1	Telephone socket	6660P
PL/SK-D	Two-way polarised connector (each part identical)	7245P
	<u>KNOBS ETC.</u>	
	Main Tuning, Incremental Tuning (less skirt)	D3613/3
	Skirt for Main Tuning and Incremental Tuning	7089/1P
	IF Gain, AF Gain, Selectivity, complete with skirt	D3614/-*
	BFO (less skirt)	D3957/-*
	Skirt for BFO	D3958
	Range Switch (bar knob)	D4012
	Dolly for Mode, Aerial Attenuator and Meter Switches	7777P
	Dolly for High-Stab/Cont Tune Switch	7778P
	Skirt for Range Knob	7703P
	Collet Knob (Black) for Cal Adjuster	8487P
	Cap for 8487P Collet Knob	8532P
	(* Add Suffix /BLACK	

(XXX)

For Service Manuals Contact  
**MAURITRON TECHNICAL SERVICES**  
8 Cherry Tree Rd, Chinnor  
Oxon OX9 4QY  
Tel: 01844-351694 Fax: 01844-352554  
Email: enquiries@maurifron.co.uk

Ref	Description	Part No.
<u>INDUCTORS</u>		
<u>NB</u> All inductors employed in the EC958 Receiver are of miniature construction. Great care should be exercised if replacement is necessary, the task being considerably simplified if proper de-soldering equipment is available. In many cases it will be found best to return the faulty module etc. to the factory so that the fault can be rectified under ideal conditions by personnel who are familiar with the intricate construction used. Items returned for servicing of this nature should carry a cover note giving the Receiver Serial No. and the Reference of the particular component(s) suspected.		
L1	935kHz Coil No. 1 (RF Assembly)	D3891A
L2	935kHz Coil No. 2 )	D3859A
L3	935kHz Coil No. 3 )	D3860A
L4	935kHz Coil No. 4 )	D3861A
L5	935kHz Coil No. 5 ) (935kHz Loop Module)	D3862A
L6	935kHz Coil No. 6 )	D3998A
L7	935kHz Coil No. 7 )	D3863B
L8	935kHz Coil No. 8 )	D3864A
L9	935kHz Coil No. 9 )	D3865A
L10	1235-1335kHz Coil No. 1 )	D3881B
L11	1235-1335kHz Coil No. 2 ) (Tunable IF Module)	D3882B
L12	1235-1335kHz Coil No. 3 )	D3883B
L13	1485-1585kHz Coil No. 1 )	D3884B
L14	1485-1585kHz Coil No. 2 ) (Tunable IF Module)	D3885B
L15	1485-1585kHz Coil No. 3 )	D3886B
L16	Incremental Oscillator Coil )	D3846B
* L17	Low-pass Filter Coil No. 1 ) (Inc. Osc. Unit)	D3847A
* L18	Low-pass Filter Coil No. 2 )	-
L19		-
L20	References not allocated	-
L21		-
L22		-
**L23	Reference not allocated	-
L24	100kHz Coil No. 2 )	D3840A
L25	100kHz Coil No. 3 )	D3841A
L26	100kHz Coil No. 4 ) (100kHz IF Filter Unit)	D3841A
L27	100kHz Coil No. 5 )	D3841A
L28	100kHz Coil No. 6 )	D3841A
L29	100kHz Coil No. 7 )	D3871A
L30	100kHz Coil No. 8 ) (100kHz IF Amplifier Module)	D3869A
L31	100kHz Coil No. 9 )	D3870A
L32	BFO Coil (CW & SSB Detector/BFO Unit)	D3853B
* Single Assembly		
** L23 was 100kHz Coil No. 1 (fitted on early receivers only)		

Ref	Description	Part No.
L33	100kHz Coil No. 10 )	D3889B
L34	100kHz Coil No. 11 ) (FSK Module)	D3890B
L35	100kHz Coil No. 12 (Master Oscillator Unit)	D3839A
L36	Range 1 Aerial Coil )	D3892C
L37	Range 2 Aerial Coil )	D3893C
L38	Range 3 Aerial Coil ) (Turret Disk "A")	D3894B
L39	Range 4 Aerial Coil )	D3895A
L40	High-pass Filter Coil No. 2 )	D3898A
L41	High-pass Filter Coil No. 1 ) (Turret Disk "A")	D3899A
L42	IF Rejector Coil - 250kHz )	D3897A
L43	IF Rejector Coil - 100kHz ) (Turret Disk "A")	D3896B
L44	Range 1 RF Coil )	D3900B
L45	Range 2 RF Coil )	D3901B
L46	Range 3 RF Coil )	D3902B
L47	Range 4 RF Coil ) (Turret Disk "B")	D3903A
L48	Range 5 RF (Aerial) Coil )	D3904A
L49	Range 6 RF (Aerial) Coil )	D3905A
L50	Range 7 RF (Aerial) Coil )	D3906A
L51	Range 8 RF (Aerial) Coil ) (Turret Disk "B")	D3907A
L52	Range 9 RF (Aerial) Coil )	D3908
L53	Range 10 RF (Aerial) Coil )	D3909A
L54	Range 1 Mixer Coil )	D3910D
L55	Range 2 Mixer Coil )	D3911B
L56	Range 3 Mixer Coil )	D3912B
L57	Range 4 Mixer Coil )	D3913B
L58	Range 5 Mixer Coil )	D3914A
L59	Range 6 Mixer Coil ) (Turret Disk "C")	D3915A
L60	Range 7 Mixer Coil )	D3916
L61	Range 8 Mixer Coil )	D3917B
L62	Range 9 Mixer Coil )	D3918
L63	Range 10 Mixer Coil )	D3919A
L64	Range 1 Oscillator Coil )	D3921
L65	Range 2 Oscillator Coil )	D3922A
L66	Range 3 Oscillator Coil )	D3923
L67	Range 4 Oscillator Coil )	D3924A
L68	Range 5 Oscillator Coil )	D3925A
L69	Range 6 Oscillator Coil ) (Turret Disk "D")	D3926A
L70	Range 7 Oscillator Coil )	D3927A
L71	Range 8 Oscillator Coil )	D3928B
L72	Range 9 Oscillator Coil )	D3930B
L73	Range 10 Oscillator Coil )	D3931C
L74	Range 1 Loop Mixer Coil )	D3932C
L75	Range 2 Loop Mixer Coil )	D3933C
L76	Range 3 Loop Mixer Coil ) (Turret Disk "E")	D3934C
L77	Range 4 Loop Mixer Coil )	D3935A
L78	Range 1 Harmonic Amplifier Coil )	D3979E
L79	Range 2 Harmonic Amplifier Coil )	D3933C
L80	Range 3 Harmonic Amplifier Coil ) (Turret Disk "F")	D4405
L81	Range 4 Harmonic Amplifier Coil )	D3935A

(XXXII)

For Service Manuals Contact  
**MAURITRON TECHNICAL SERVICES**  
8 Cherry Tree Rd, Chinnor  
Oxon OX9 4QY  
Tel: 01844-351694 Fax: 01844-352554  
Email: enquiries@mauritron.co.uk

Ref	Description	Part No.
<u>CHOKES</u>		
CH1	47 microhenries )	7753P
CH2	10 microhenries )	7752P
CH3	10 microhenries )	7752P
CH4	47 microhenries )	7753P
CH5	4.7 millihenries )	7472P
CH6	4.7 millihenries )	7472P
CH7	4.7 millihenries )	7472P
CH8	4.7 millihenries )	7472P
CH9	1 millihenry )	7754P
CH10	4.7 millihenries )	7472P
CH11	100 millihenries )	7350P
CH12	68 millihenries )	7759P
CH13	27.5 microhenries )	D2413
CH15	1 millihenry )	7754P
CH15A	560 microhenries )	8042P
CH16	4.7 millihenries )	7472P
CH17	330 microhenries )	8400P
CH17A	220 microhenries )	8401P
CH18	68 millihenries )	7759P
CH19	68 millihenries )	7759P
CH20	68 millihenries )	7759P
CH21	68 millihenries )	7759P
CH22	100 millihenries )	7350P
CH23	100 millihenries )	7350P
CH24	4.7 millihenries )	7472P
CH25	68 millihenries )	7759P
CH26	1 millihenry )	7754P
CH27	100 millihenries )	7350P
CH28	1 millihenry )	7754P
CH29	68 millihenries )	7759P
CH30	4.7 millihenries )	7472P
CH31	100 millihenries )	7350P
CH32	100 millihenries )	7350P
CH33	3 microhenries )	D2854/1C
CH34	3 microhenries )	D2854/1C
CH35	100 microhenries )	7760P
CH36	4.7 millihenries )	7472P
<u>TRANSFORMERS</u>		
T1	600/75-ohm Balun Transformer	D3850A
T2	600-ohm Line Output Transformer	7524P
T3	Audio Driver Transformer (3-ohm Channel)	7523P
T4	3-ohm Output Transformer	7553P
T5	Power Transformer	7600P
<u>NB:</u> Reference CH14 not allocated.		

Ref	Description	Part No.
	<u>BULBS AND FUSES</u>	
LP1-3	Standard L. E. S. 6V, 60mA. (legend lamps)	6659P
LP4-5	Projection Bulb (6V, 0.2A, MES cap, 10mm round)	8542P
FS1	Standard 5/8" x 3/16" glass cartridge rated at 2A	6704P
FS2	Standard 5/8" x 3/16" glass cartridge rated at 1A	7173P
-	Fuseholder	6372P
-	Lampholder (L. E. S.)	6600P
-	Holder/Carrier for Projection Bulb	D4564
	<u>DRIVE ASSEMBLY</u>	
	Special jigs are required for assembly of this unit. Receiver should be returned to our factory for repair, or special arrangements can be made to supply a complete replacement mechanism on receipt of faulty unit.	
	<u>OPTICS - SCALE DISPLAY</u>	
	Light Unit - Main Tune (complete assembly)	D3975
	Light Unit - Incremental (complete assembly)	D3975/1
	Lens Block (Incremental Display)	D3973
	Lens Block (Main Display)	D3974
	Calibration Disk (Incremental Display)	7483PA
	Calibration Disk (Main Display)	7571PB
	<u>MISCELLANEOUS</u>	
	Panel Handles	8253P
	Meter (50-0-50uA with special scaling)	7489P
	Panel Speaker	6101P
	Grille for Panel Speaker	6976P
	Dial Escutcheon	7397PA
	Finger Plate (Standard EC958)	8404PC
	Finger Plate (Model EC958/1)	8416PD
	Flexible Coupler	7327P
	Module Box (as used for Tunable IF etc.)	7521PA
	Screwdriver	7612P
	Trimming Tool (Neosid Type T. T. 1.)	8451P
	Disk Insertion Tool	7857P
	Dust Cover (top)	8408/LPB
	Dust Cover (bottom)	8408PC
	Flexible Coupler (for tuning gangs)	D4537



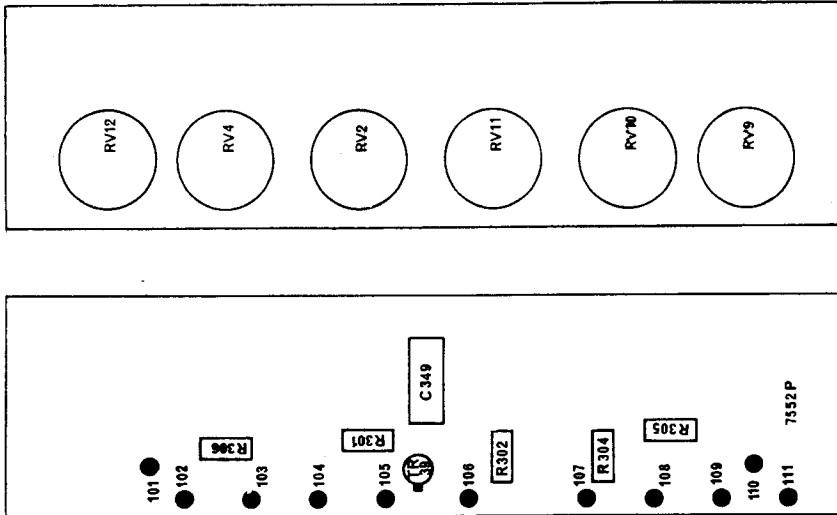

MODULE BOARDS

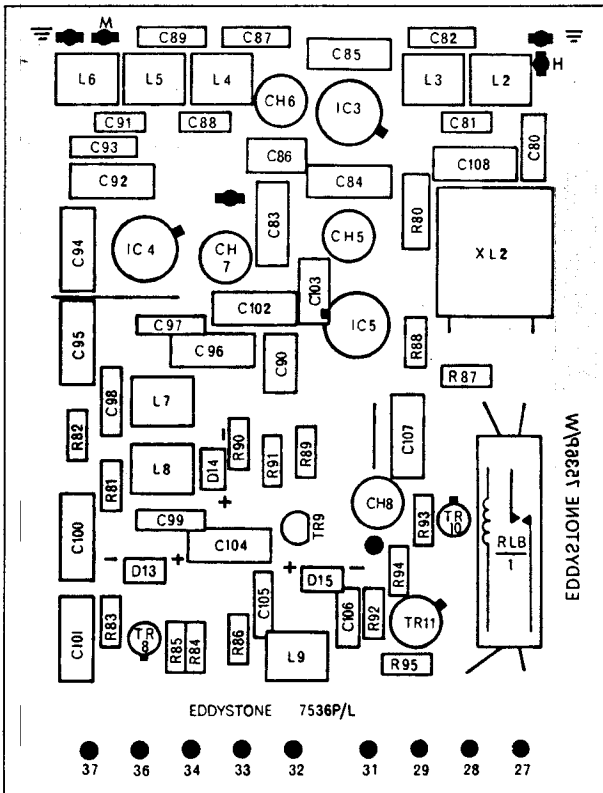

Module No. 1. 935kHz LOOP AMPLIFIER

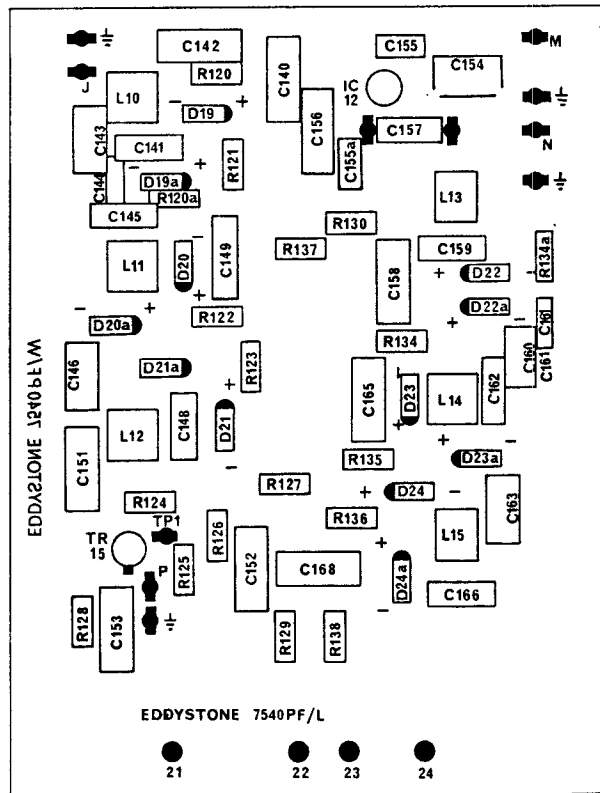

Module No. 2. TUNABLE IF

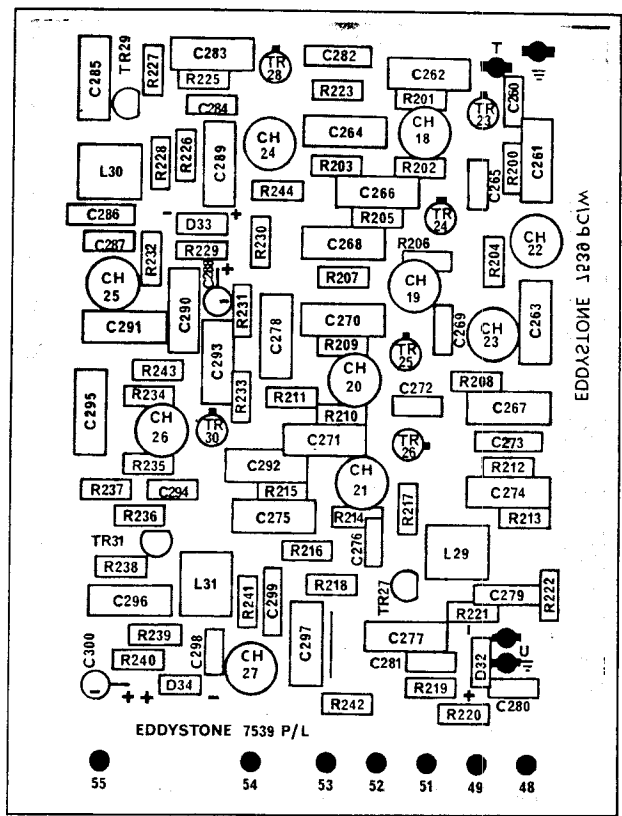
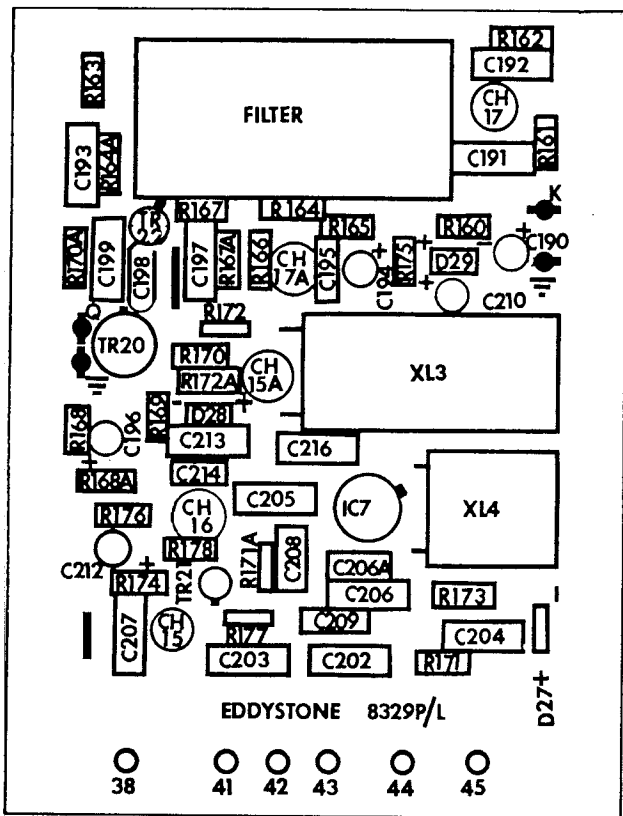

For Service Manuals Contact  
**MAURITRON TECHNICAL SERVICES**  
 8 Cherry Tree Rd, Chinnor  
 Oxon OX9 4QY  
 Tel: 01844-351694 Fax: 01844-352554  
 Email: enquiries@mauritron.co.uk

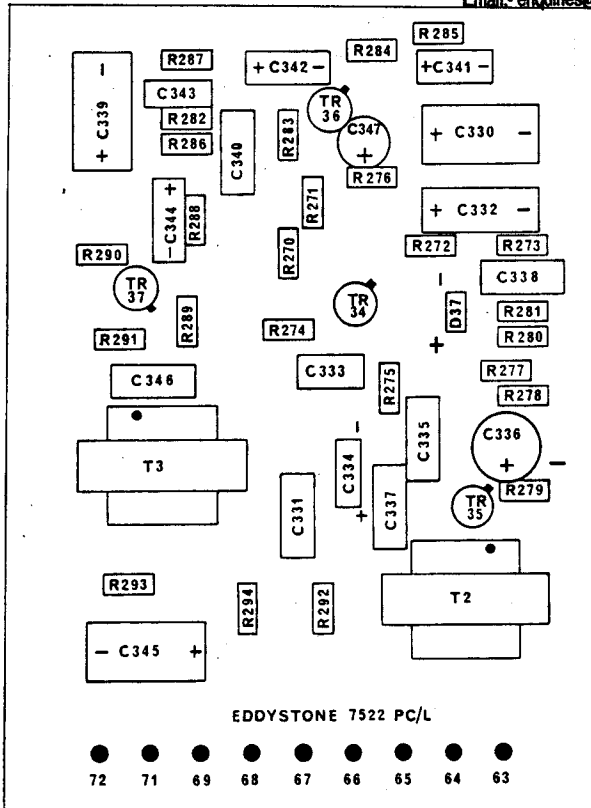

Module No. 5. AUDIO AMPLIFIERS

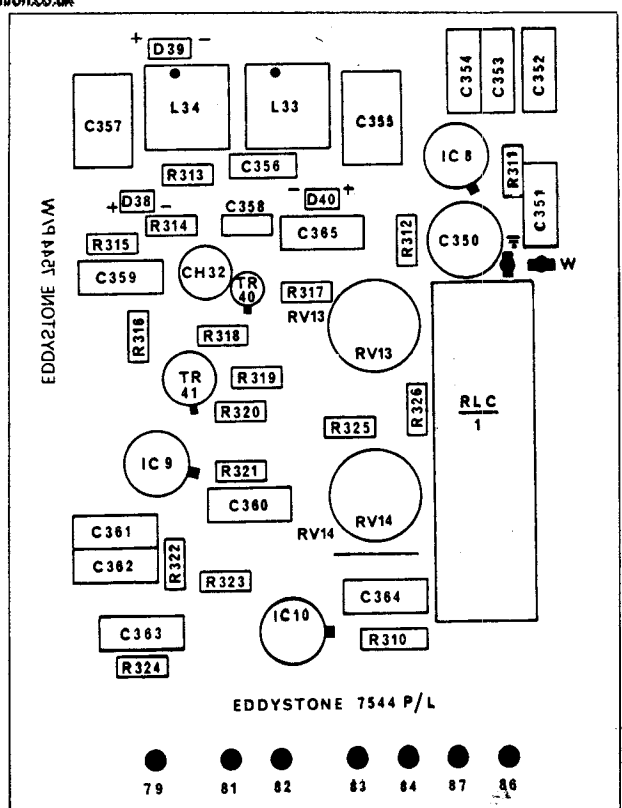

Module No. 6. FSK (Optional)

# UNIT BOARDS

- \* 1. AERIAL ATTENUATOR UNIT
- 2. MASTER OSCILLATOR UNIT
- \* 3. INCREMENTAL OSCILLATOR UNIT

- 4. 100kHz IF FILTER UNIT
- 5. CW/SSB DETECTOR & BFO UNIT
- \* Double-sided boards

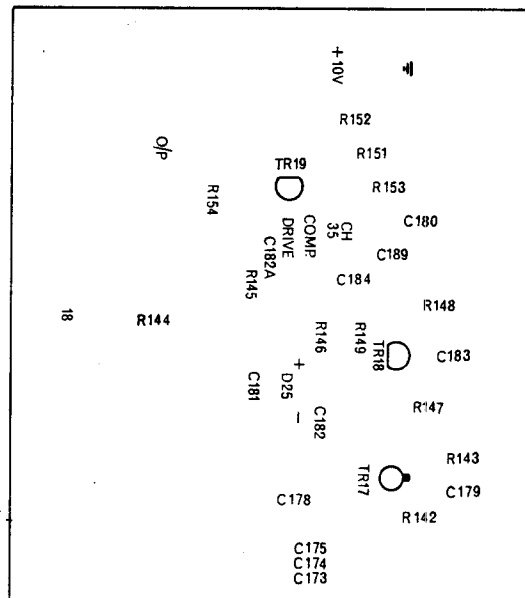
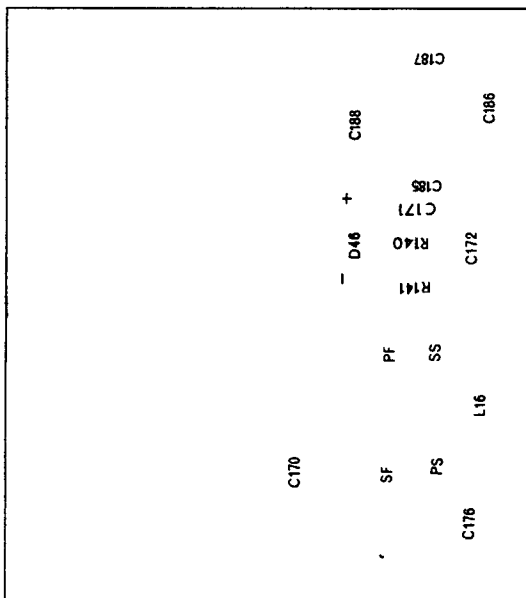
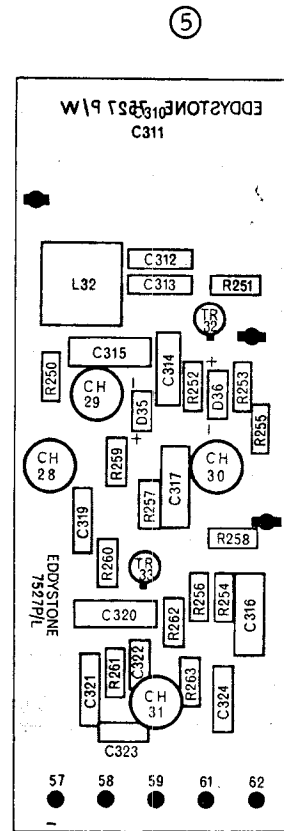
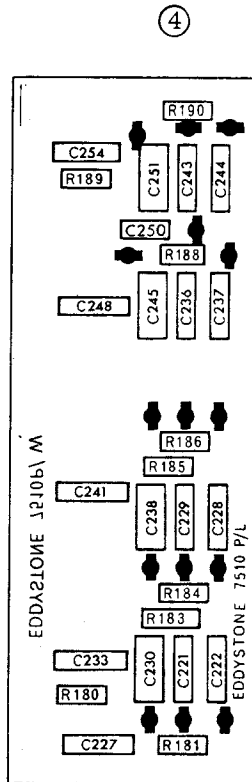
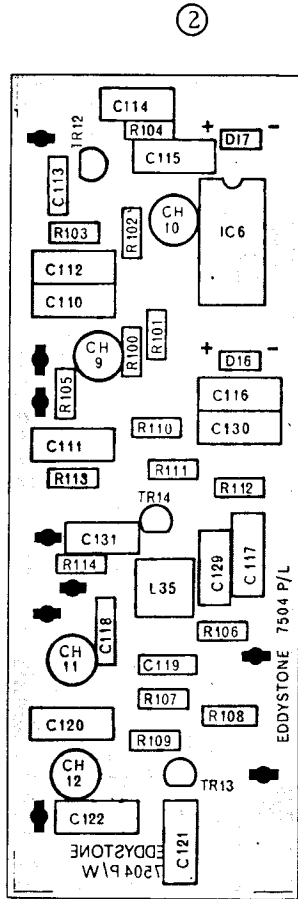
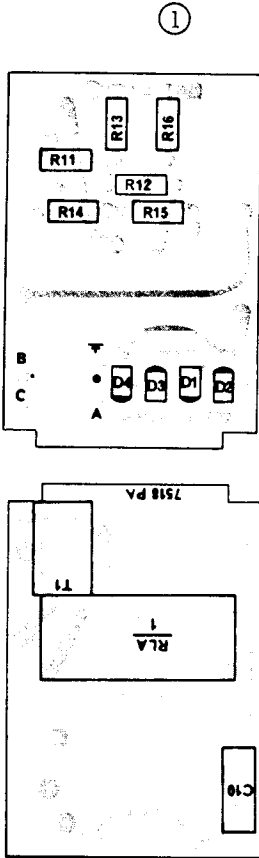

TURRET DISKS

DISK 'A' AERIAL

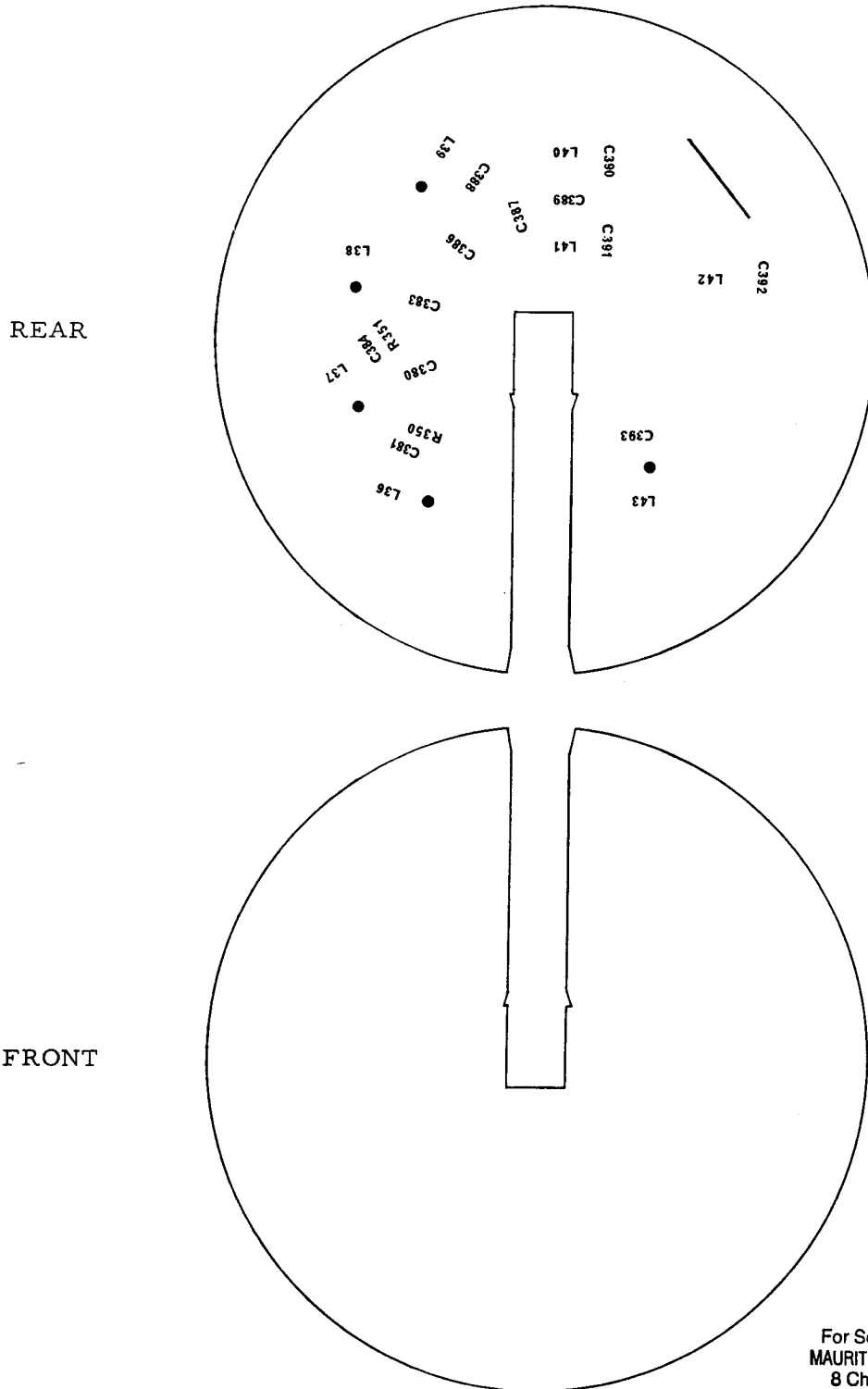

For Service Manuals Contact  
MAURITRON TECHNICAL SERVICES  
8 Cherry Tree Rd, Chinnor  
Oxon OX9 4QY  
Tel:- 01844-351694 Fax:- 01844-352554  
Email:- enquiries@mauritron.co.uk

DISK 'B' RF

REAR

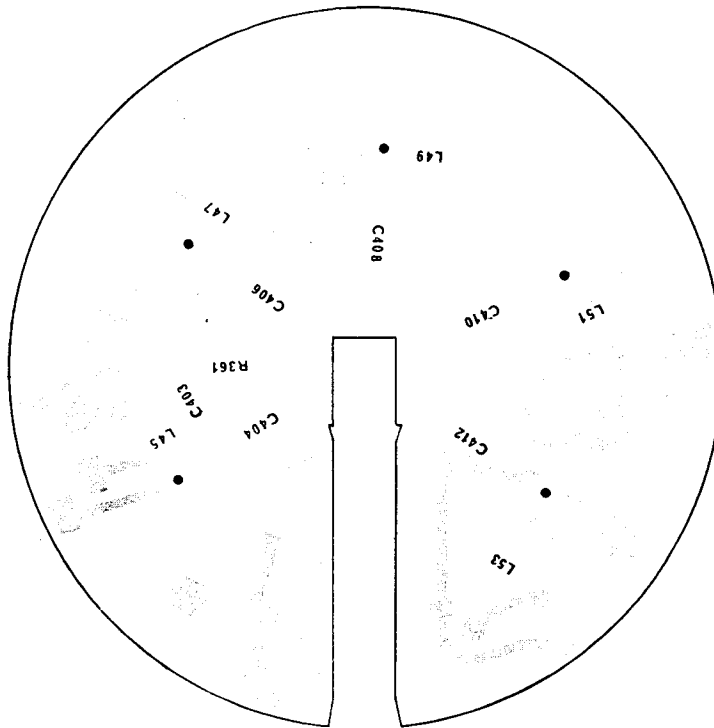

FRONT

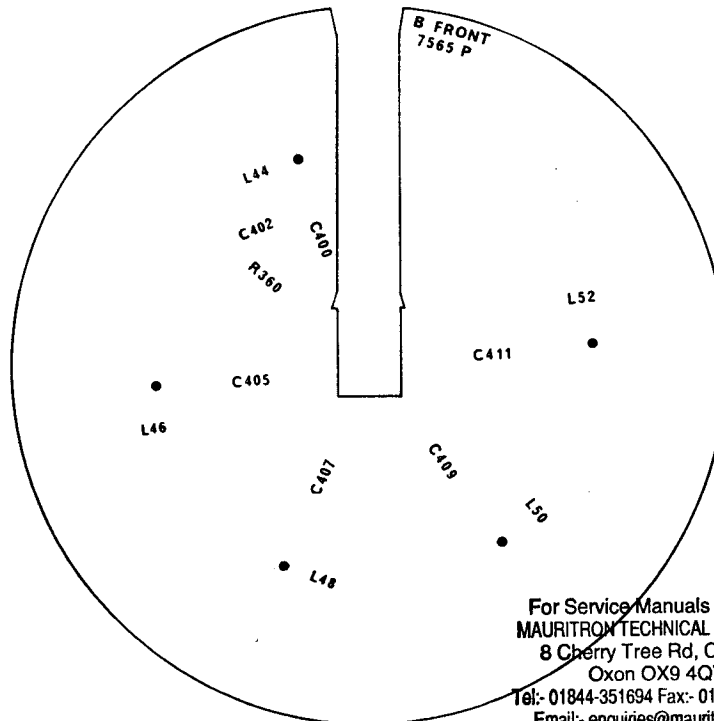

For Service Manuals Contact  
MAURITRON TECHNICAL SERVICES  
8 Cherry Tree Rd, Chinnor  
Oxon OX9 4QY  
Tel:- 01844-351694 Fax:- 01844-352554  
Email:- enquiries@mauritron.co.uk

DISK 'C' SIGNAL MIXER

REAR

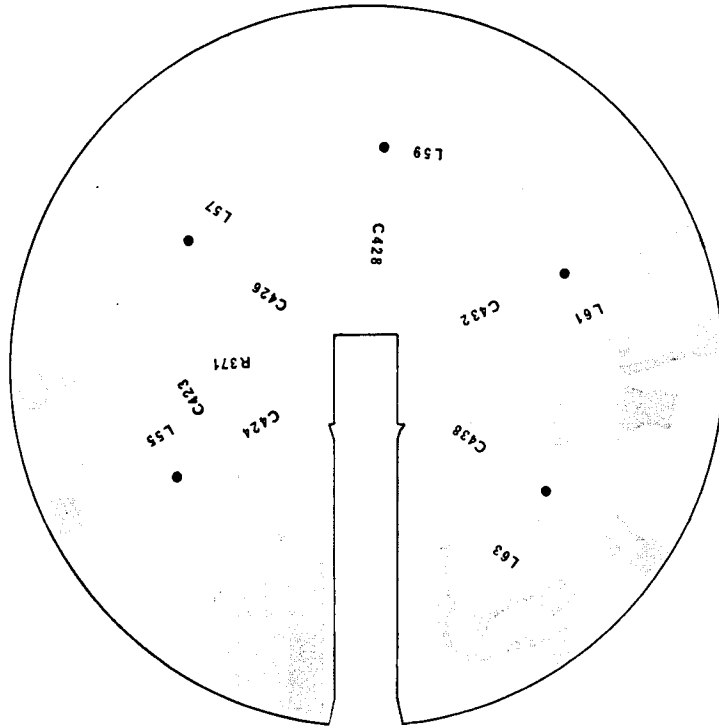

FRONT

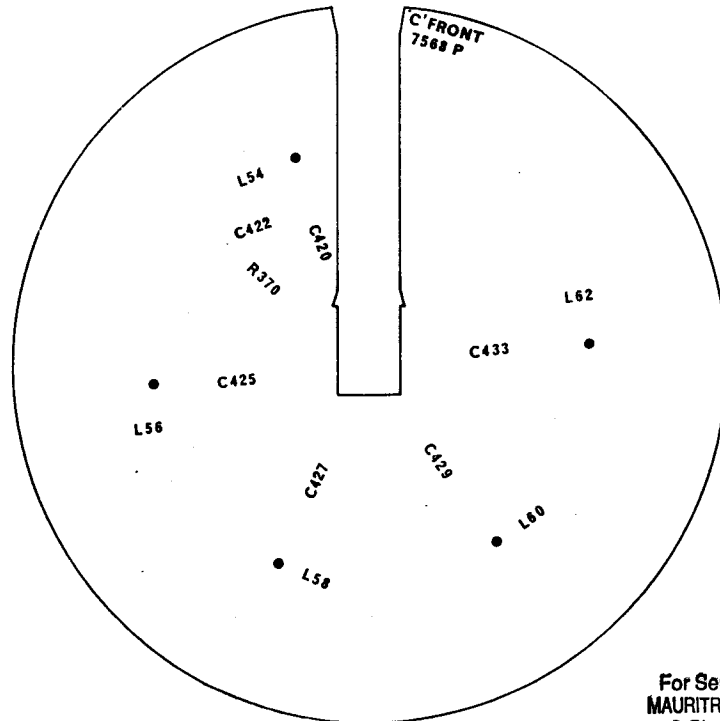

For Service Manuals Contact  
MAURITRON TECHNICAL SERVICES  
8 Cherry Tree Rd, Chinnor  
Oxon OX9 4QY  
Tel:- 01844-351694 Fax:- 01844-352554  
Email:- enquiries@mauritron.co.uk

DISK 'D' MAIN-TUNE OSCILLATOR

REAR

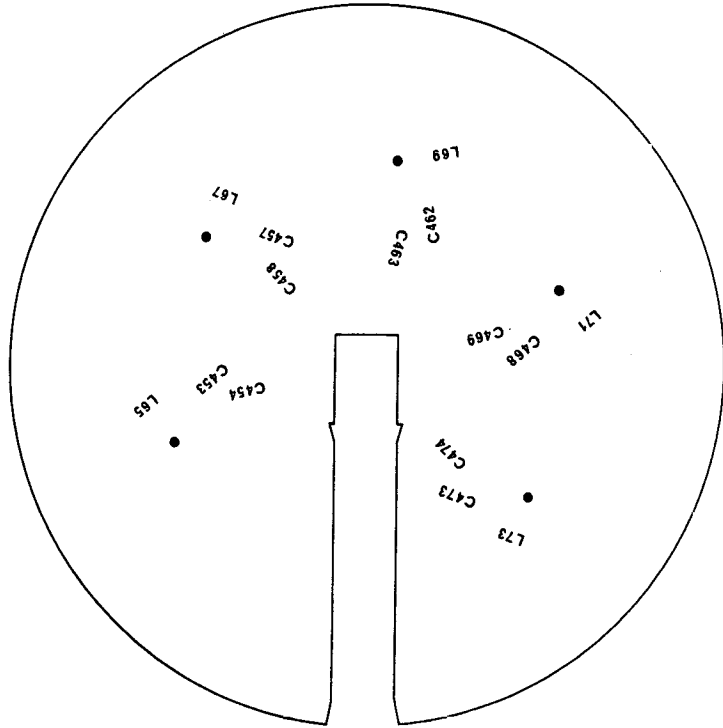

FRONT

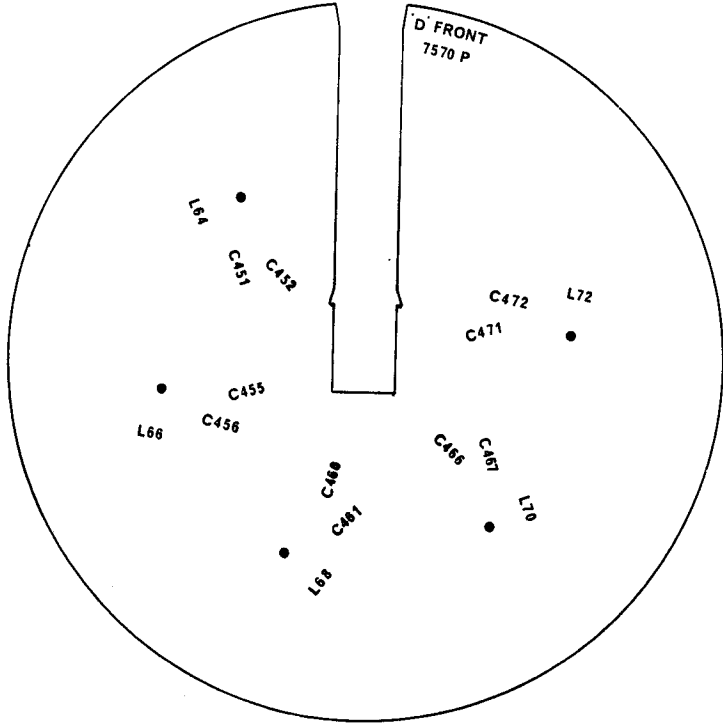

For Service Manuals Contact  
MAURITRON TECHNICAL SERVICES  
8 Cherry Tree Rd, Chinnor  
Oxon OX9 4QY  
Tel:- 01844-351694 Fax:- 01844-352554  
Email:- enquiries@mauritron.co.uk

DISK 'E' LOOP MIXER

REAR

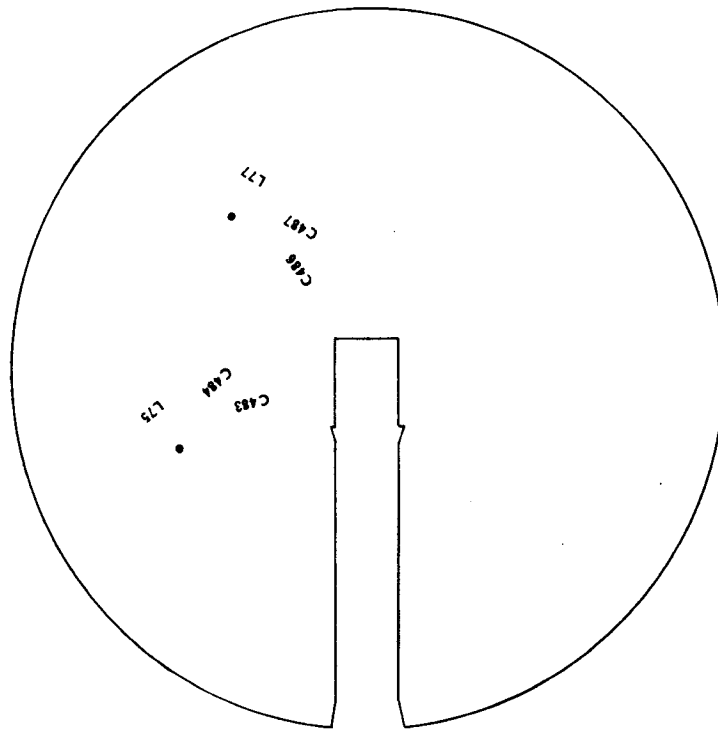

FRONT

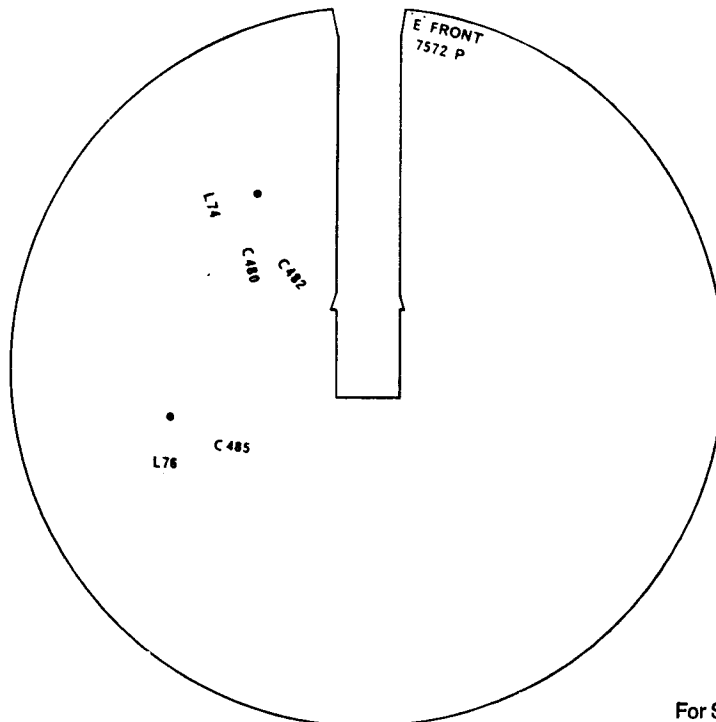

For Service Manuals Contact  
MAURITRON TECHNICAL SERVICES  
8 Cherry Tree Rd, Chinnor  
Oxon OX9 4QY  
Tel:- 01844-351694 Fax:- 01844-352554  
Email:- enquiries@mauritron.co.uk

DISK 'F' HARMONIC AMPLIFIER

REAR

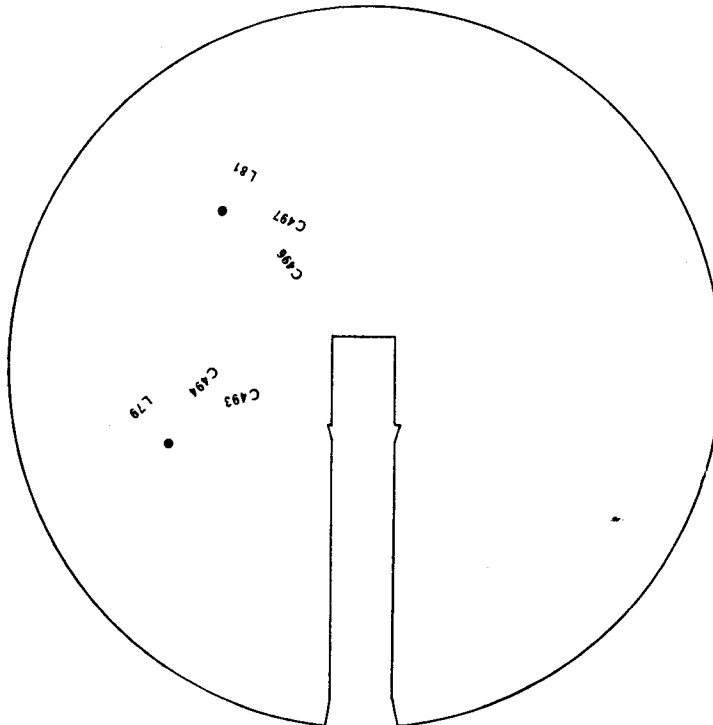

FRONT

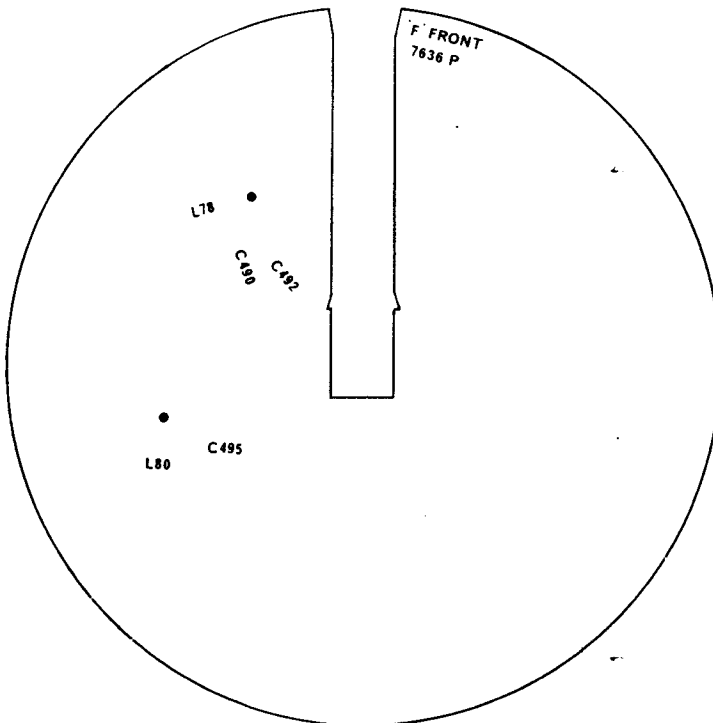

For Service Manuals Contact  
MAURITRON TECHNICAL SERVICES  
8 Cherry Tree Rd, Chinnor  
Oxon OX9 4QY  
Tel:- 01844-351694 Fax:- 01844-352554  
Email:- enquires@mauritron.co.uk

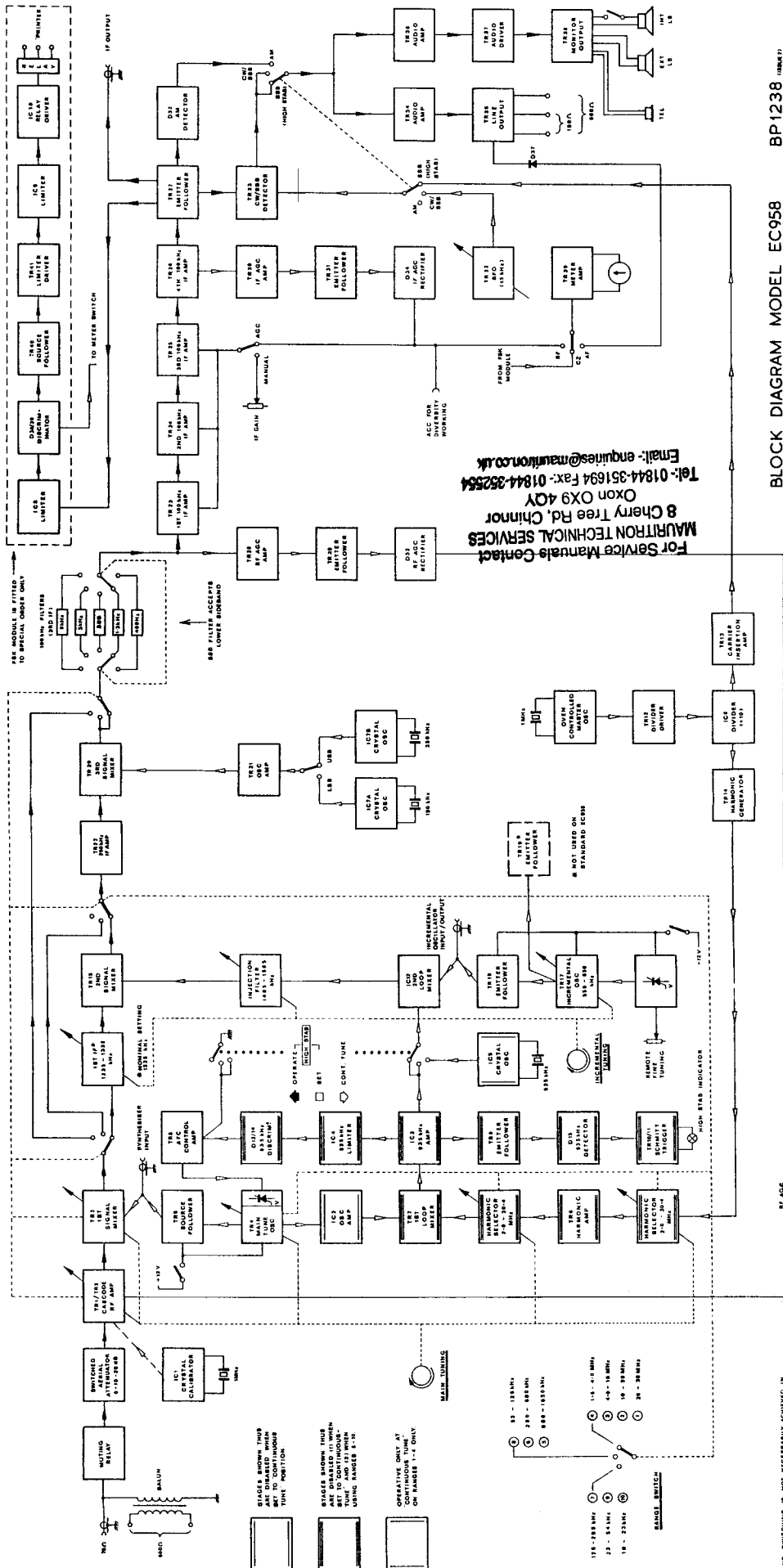

BP1238 (REV. 87)

BLOCK DIAGRAM MODEL EC958

NOT REPRODUCING IS NOT NECESSARILY ACCEPTED IN THE UNITED KINGDOM OR THE REPUBLIC OF IRELAND



**REVISIONS**  
 C475 :: 50pF  
 C491 :: 50pF

For Service Manuals Contact  
**MAURITRON TECHNICAL SERVICES**  
 8 Cherry Tree Rd, Chinnor  
 Oxon, OX9 4QY  
 Tel: 01844-351694 Fax: 01844-352554  
 Email: enquiries@mauritron.co.uk

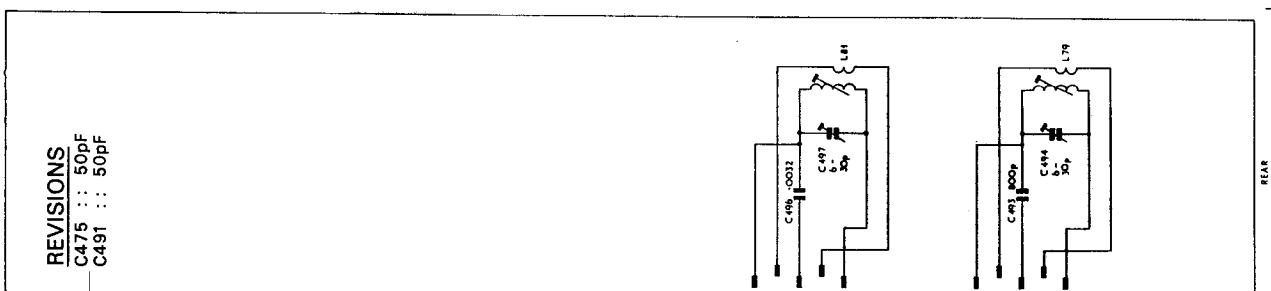
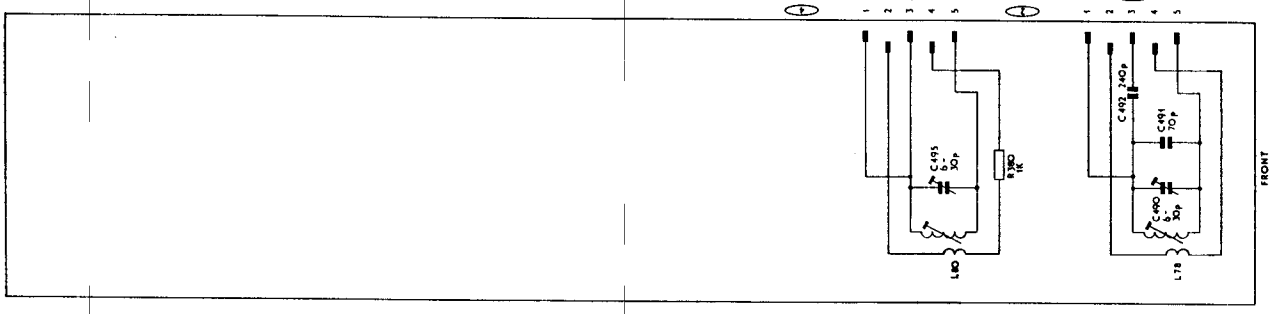
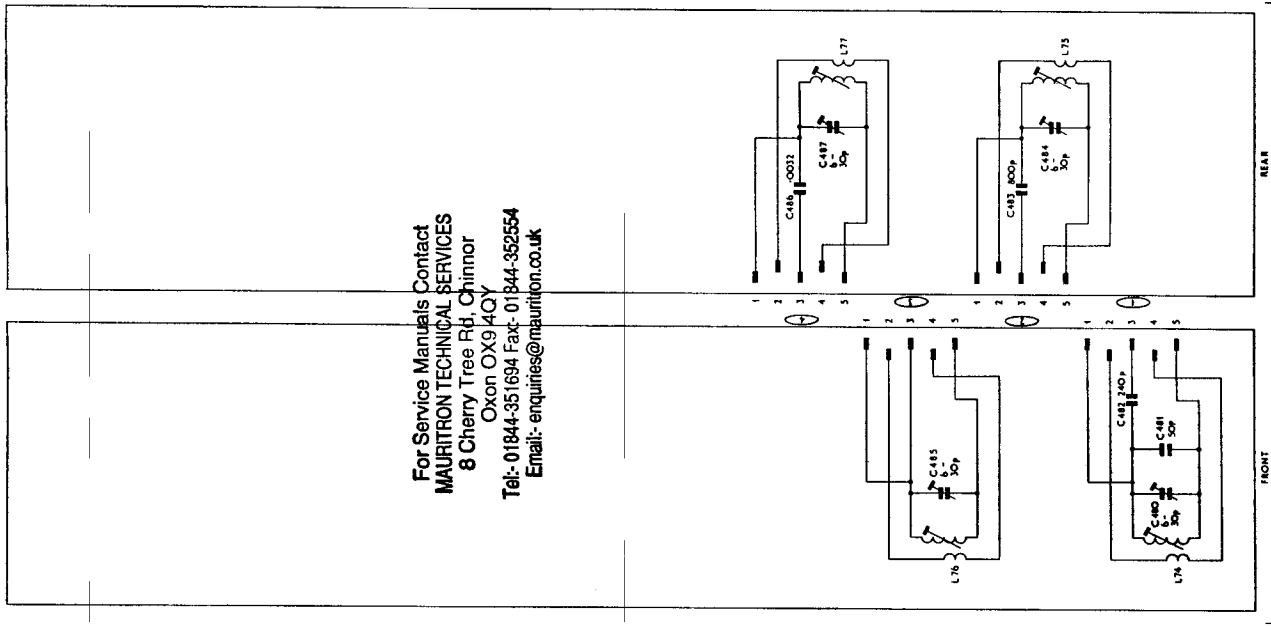
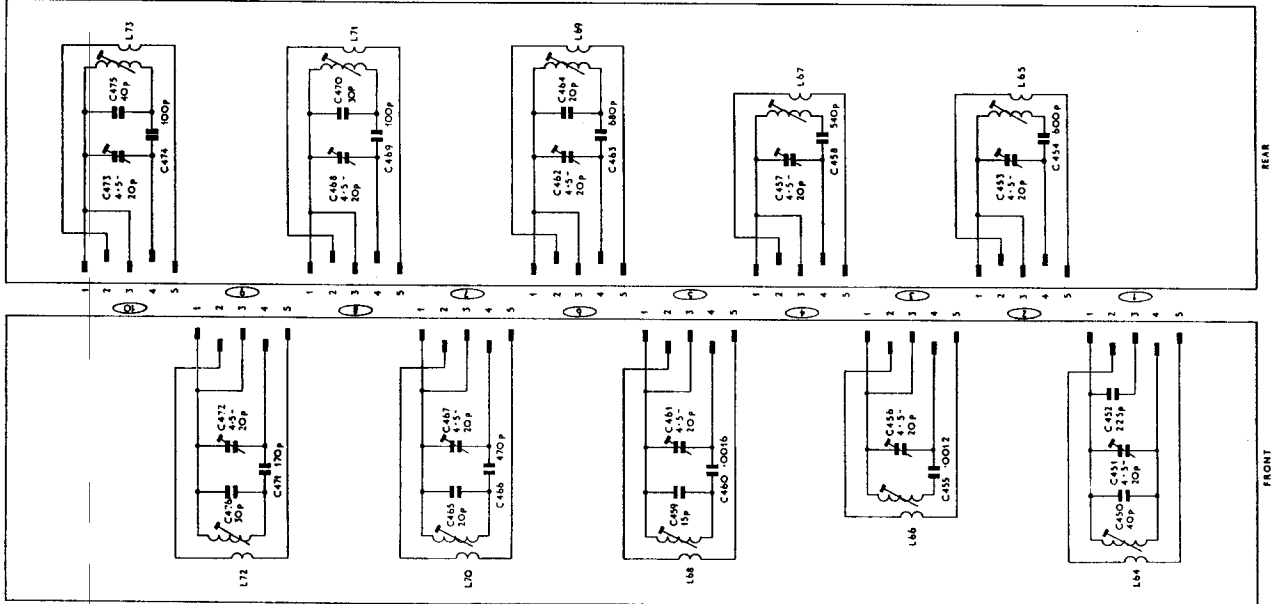

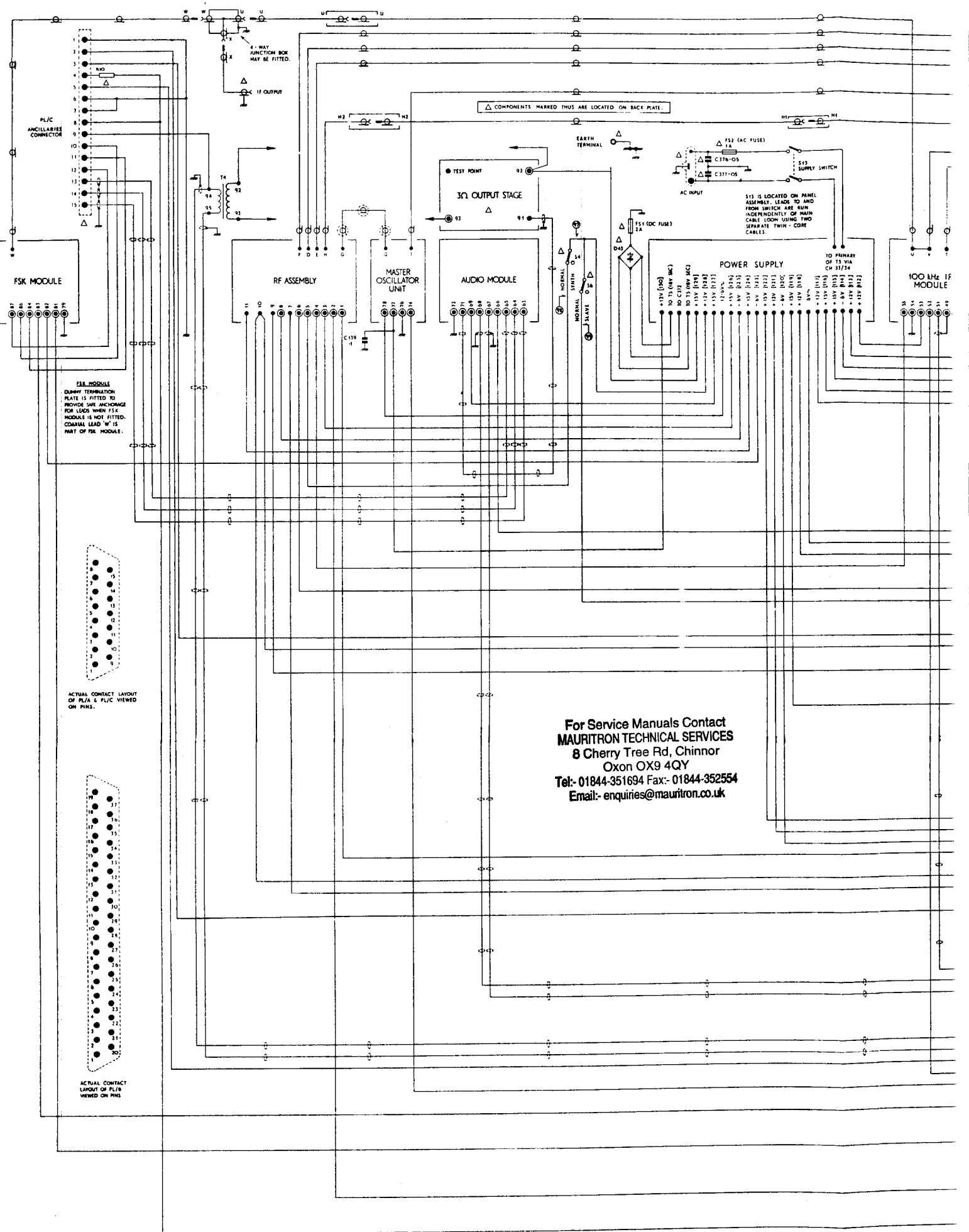

**S13 MODULE**  
 DUMMY TERMINATION PLATE IS FITTED TO PROVIDE SAFE ANCHORAGE FOR LEADS WHEN FSK MODULE IS NOT FITTED. CONSOLE LEAD 'W' IS PART OF FSK MODULE.

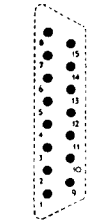

ACTUAL CONTACT LAYOUT OF PL/A & PL/C VIEWED ON PINS.

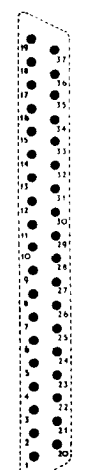

ACTUAL CONTACT LAYOUT OF PL/B VIEWED ON PINS.

**For Service Manuals Contact  
 MAURITRON TECHNICAL SERVICES  
 8 Cherry Tree Rd, Chinnor  
 Oxon OX9 4QY  
 Tel: 01844-351694 Fax: 01844-352554  
 Email: enquiries@mauritron.co.uk**

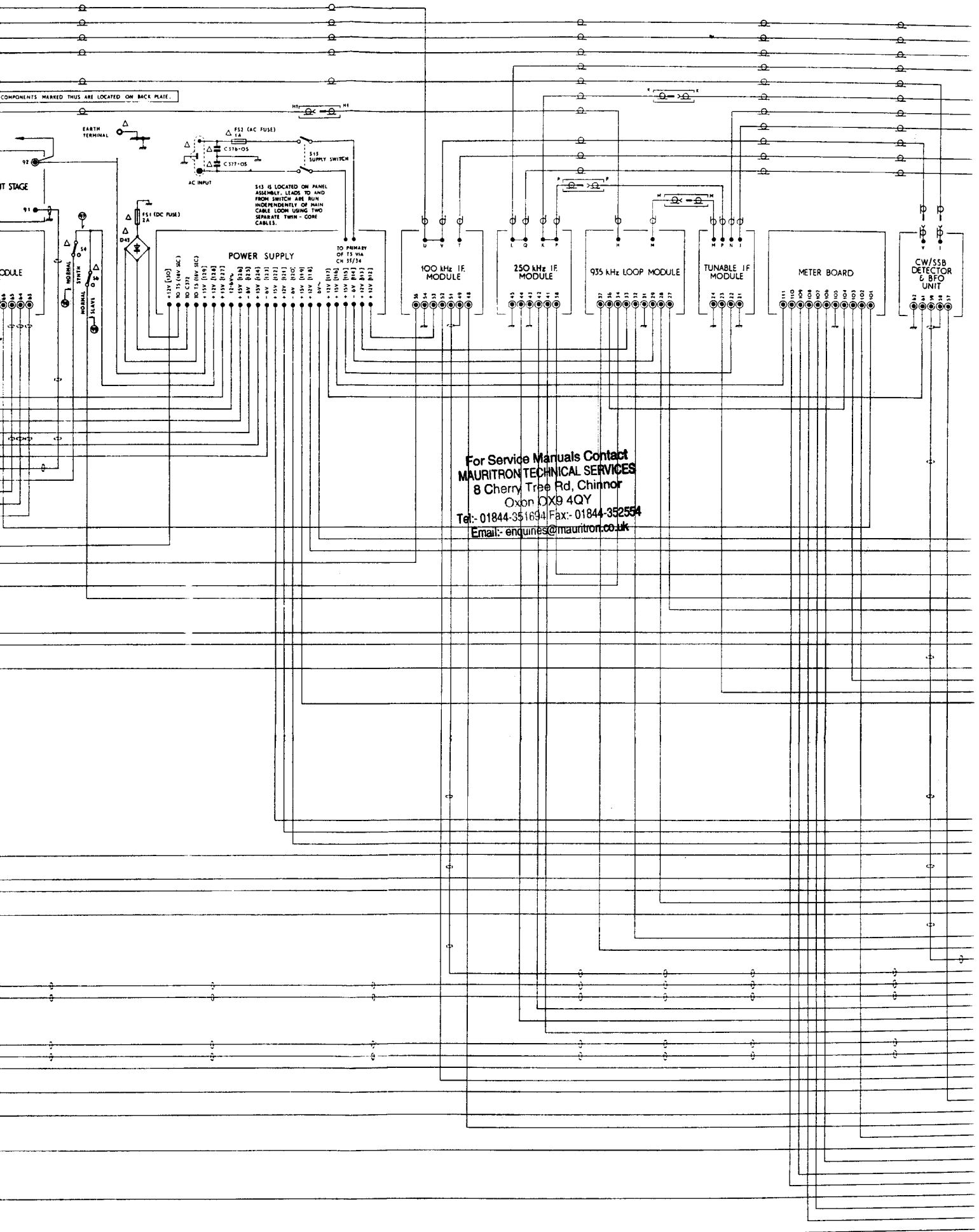

For Service Manuals Contact  
**MAURITRON TECHNICAL SERVICES**  
 8 Cherry Tree Rd, Chinnor  
 Oxon OX9 4QY  
 Tel: 01844-351694 Fax: 01844-352554  
 Email: [enquiries@mauritron.co.uk](mailto:enquiries@mauritron.co.uk)

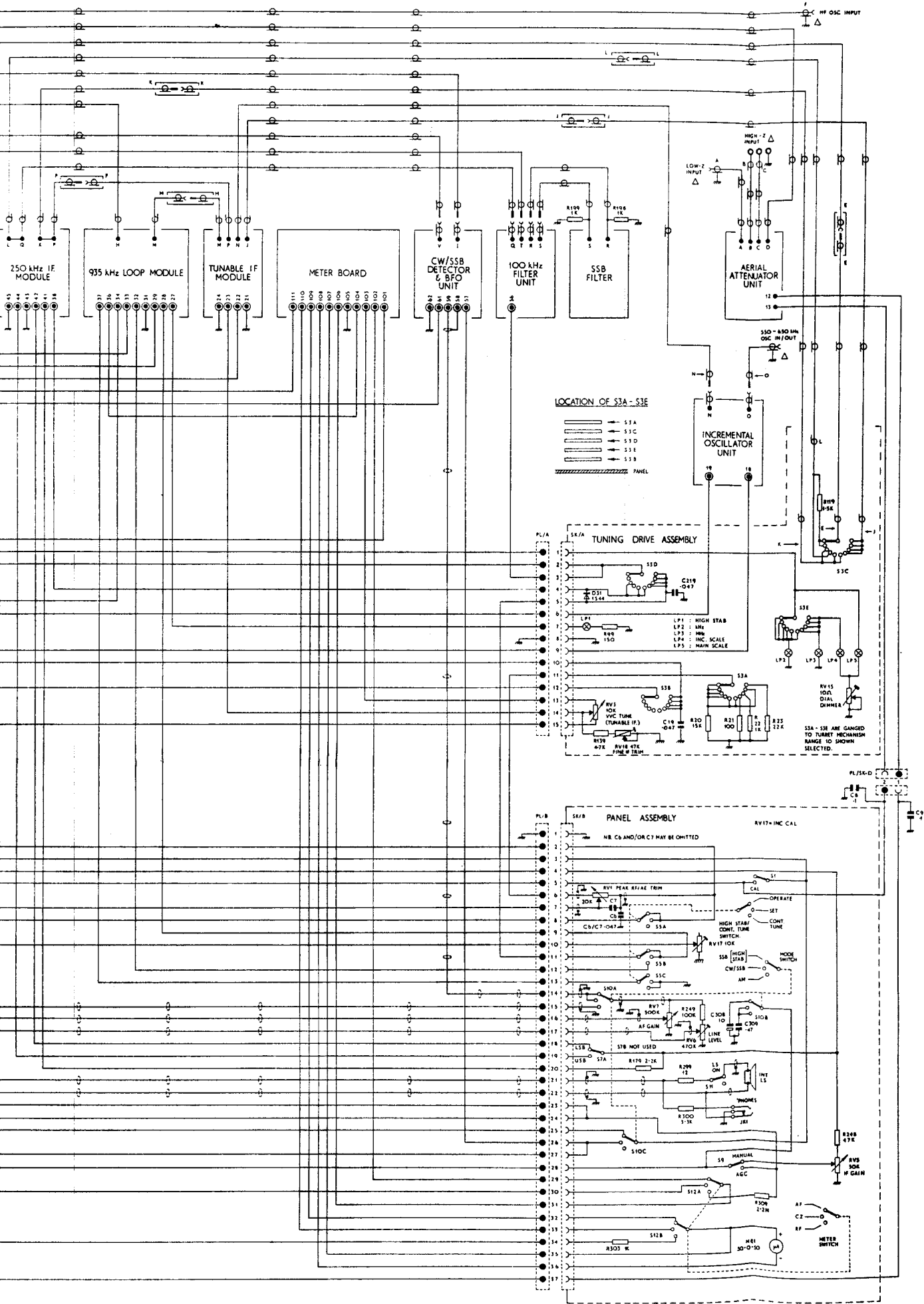

INTERCONNECTION CIRCUIT - MODEL EC958

ISSUE 3

For Service Manuals Contact  
**MAURITRON TECHNICAL SERVICES**  
 8 Cherry Tree Rd, Chinnor  
 Oxon OX9 4QY  
 Tel: 01844-351694 Fax: 01844-352554  
 Email: enquiries@mauritron.co.uk

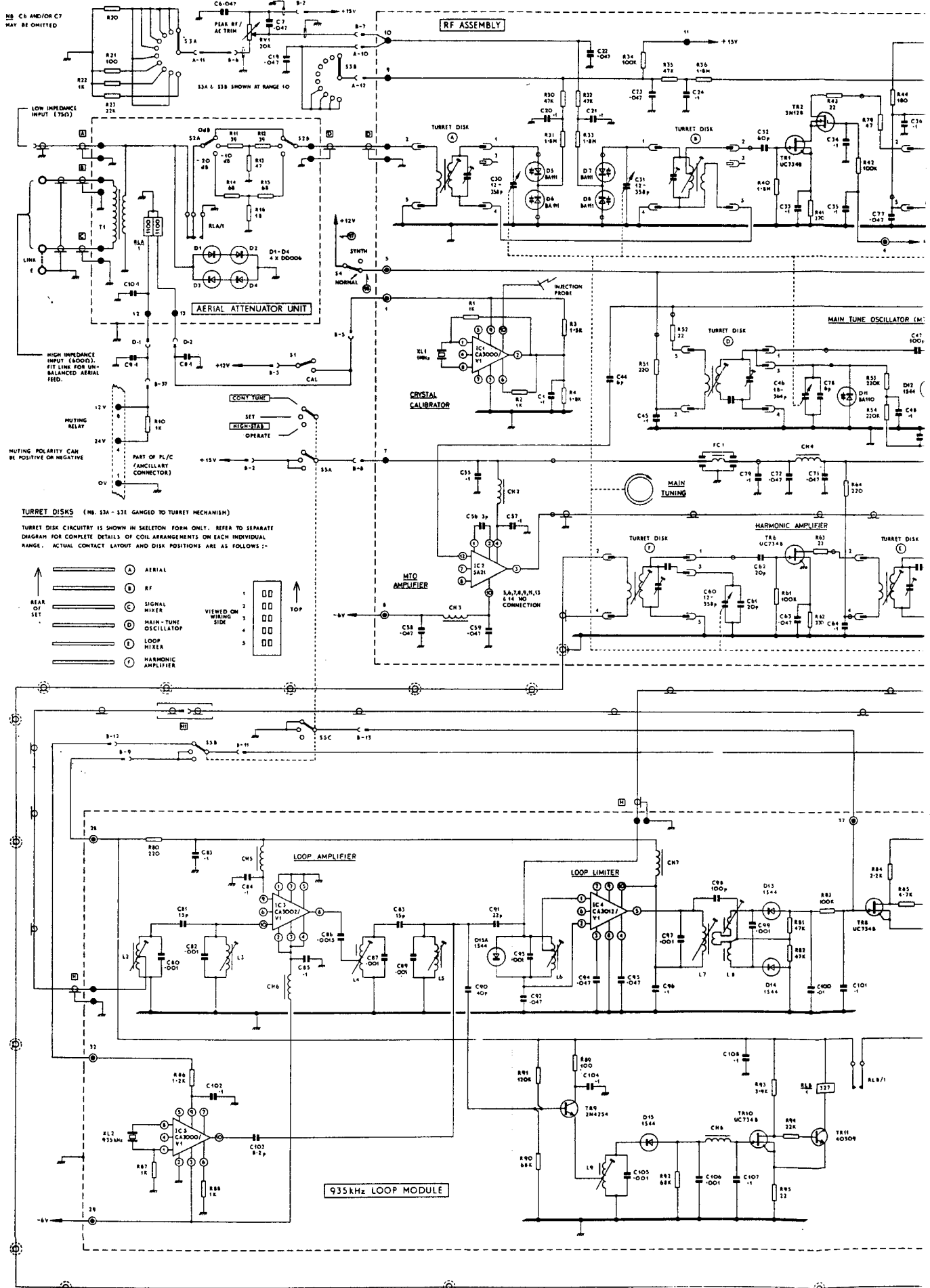

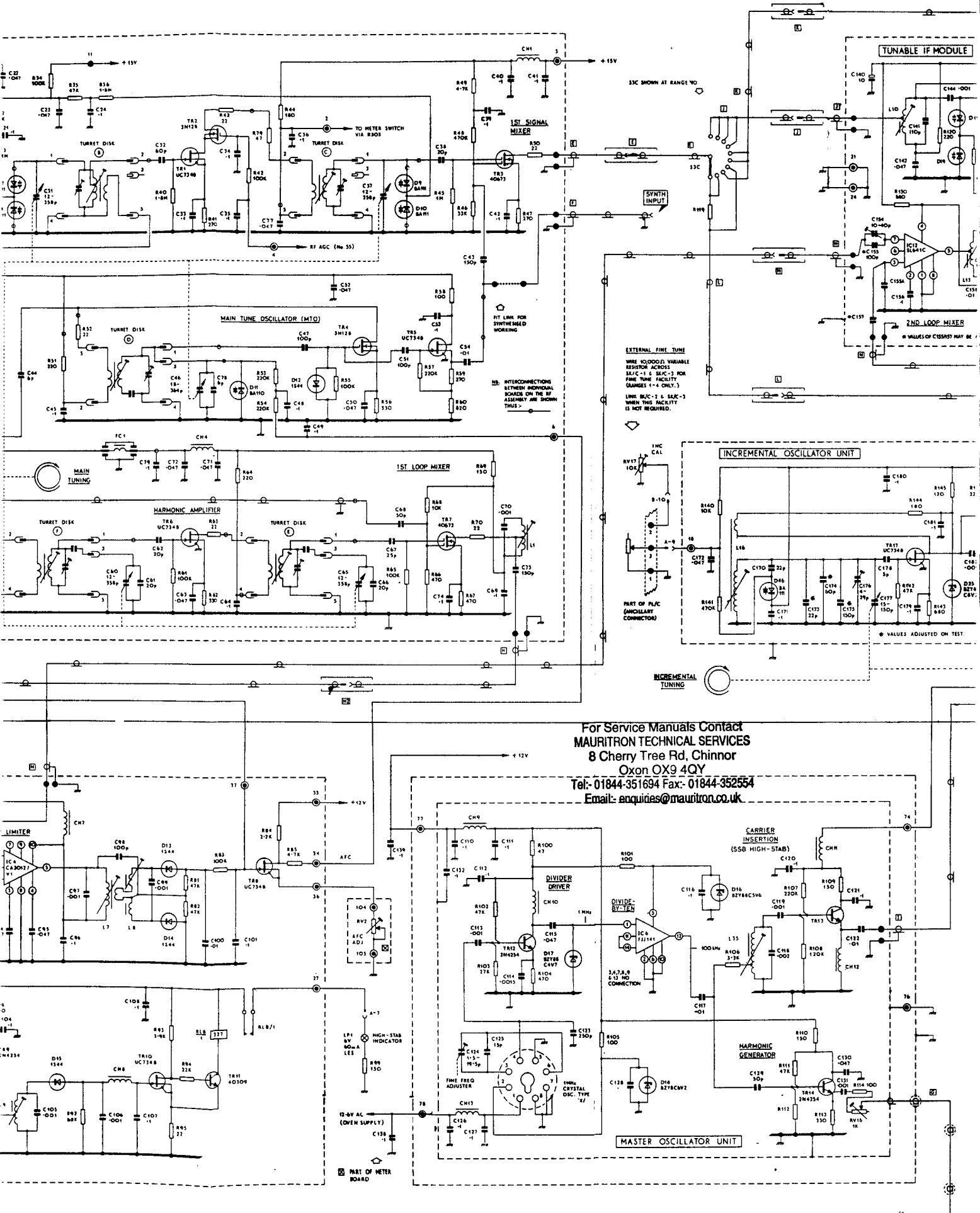

For Service Manuals Contact  
**MAURITRON TECHNICAL SERVICES**  
 8 Cherry Tree Rd, Chinnor  
 Oxon OX9 4QY  
 Tel: 01844-351694 Fax: 01844-352554  
 Email: enquiries@mauritron.co.uk

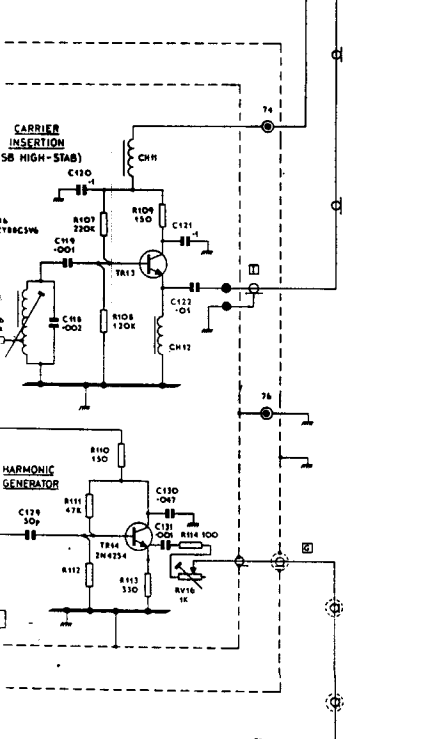
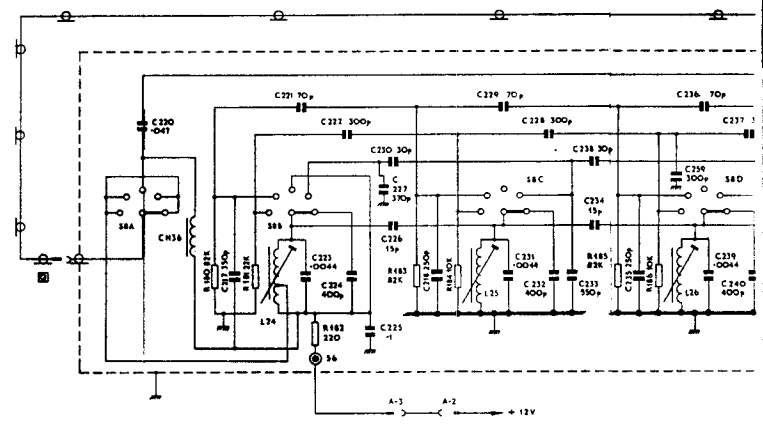
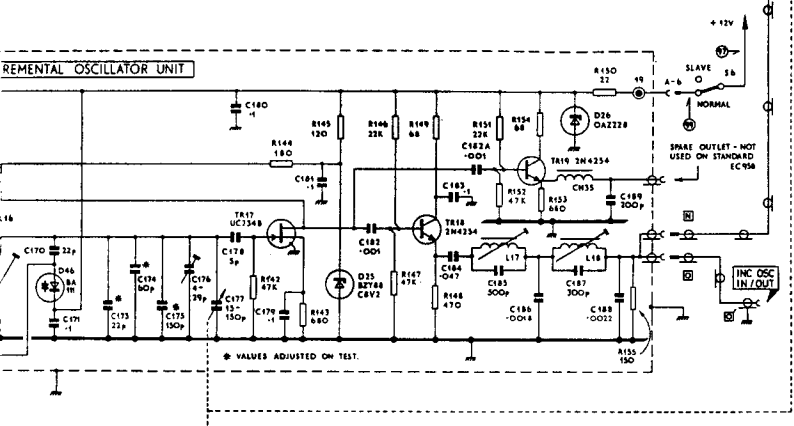
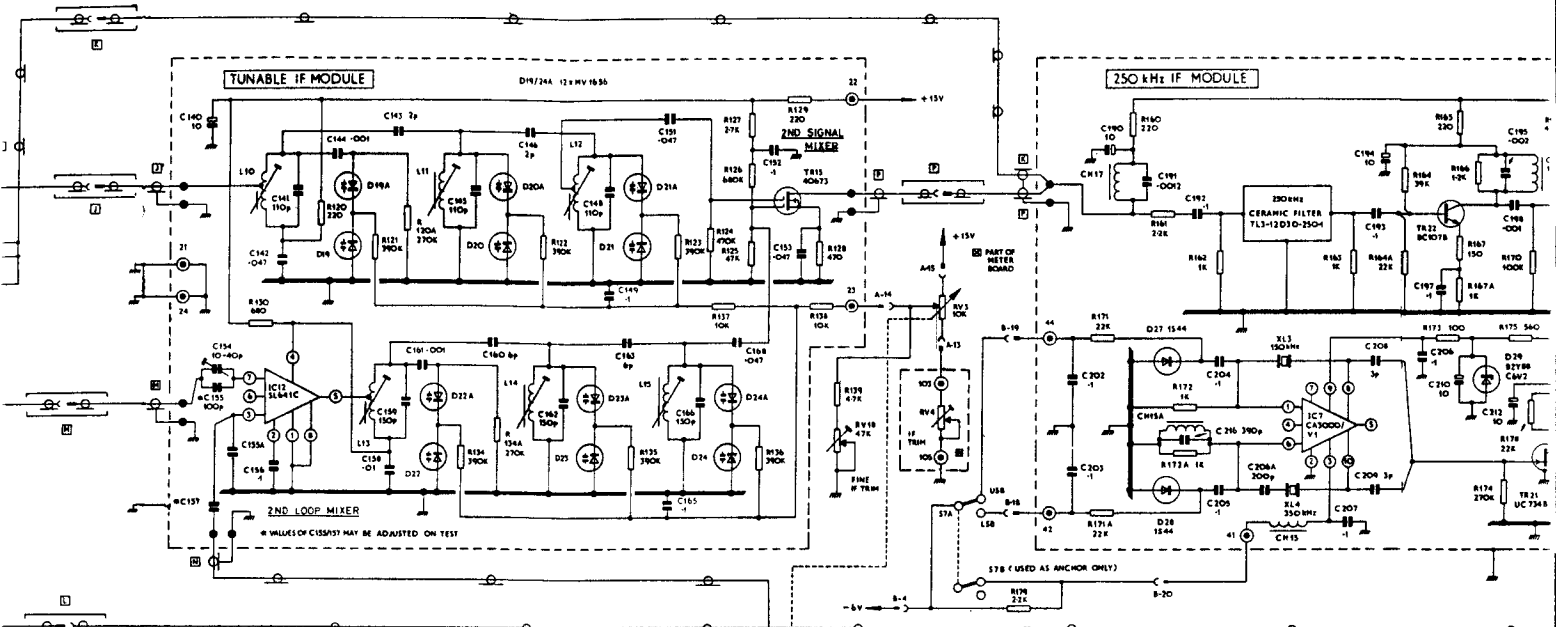

<p><b>2N4254</b> TO-92</p> <p>1 BASE 2 COLLECTOR 3 EMITTER</p>	<p><b>40309</b> TO-5</p> <p>1 EMITTER 2 BASE 3 COLLECTOR AND CASE</p>
<p><b>2N3054</b> TO-66</p> <p>1 BASE 2 EMITTER 3 COLLECTOR AND CASE</p>	<p><b>BC107B</b> TO-18</p> <p>1 EMITTER 2 BASE 3 COLLECTOR AND CASE</p>
<p><b>3N128</b> TO-72</p> <p>1 DRAIN 3 SOURCE 4 GATE 2 SUBSTRATE AND CASE</p>	<p><b>BCY34</b> TO-5</p> <p>1 EMITTER 2 BASE 3 COLLECTOR</p>
<p><b>40673</b> TO-72</p> <p>1 DRAIN 2 GATE 1 3 GATE 2 4 SUBSTRATE SOURCE AND CASE</p>	<p><b>UC734B</b> TO-72</p> <p>1 SOURCE 2 DRAIN 3 GATE 4 CASE</p>

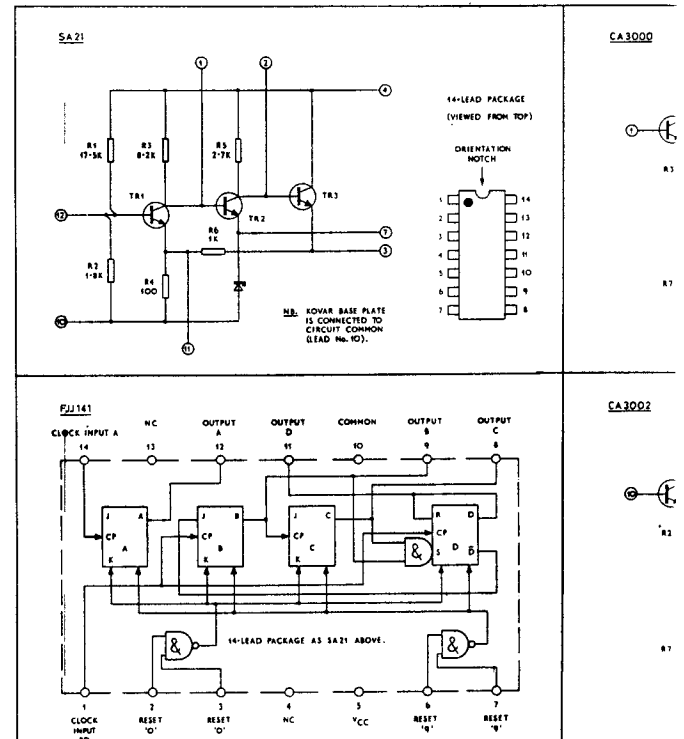

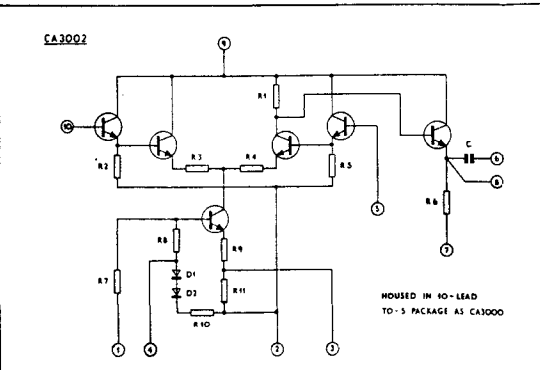
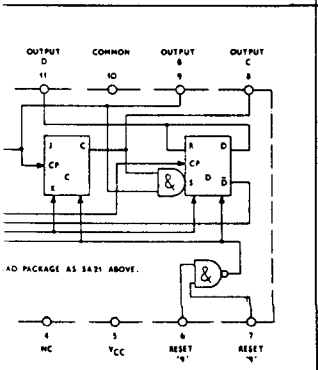
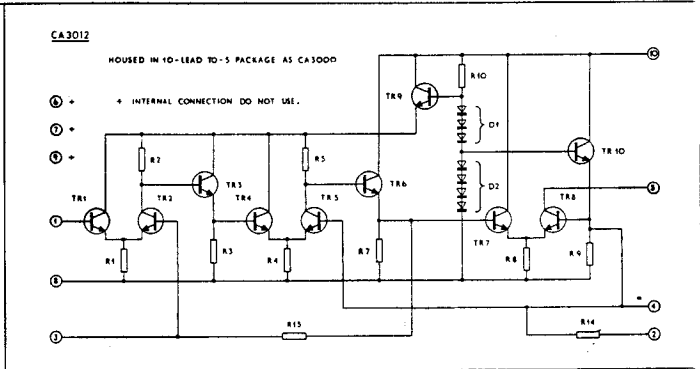
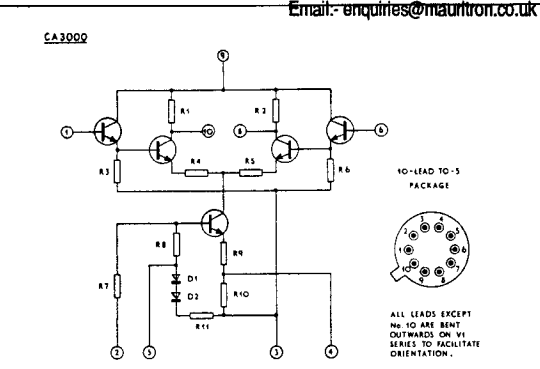
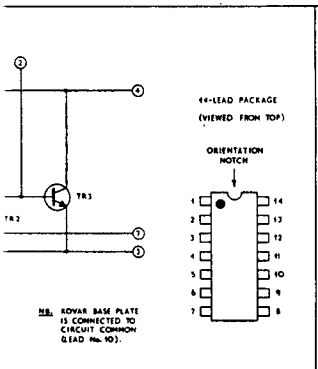
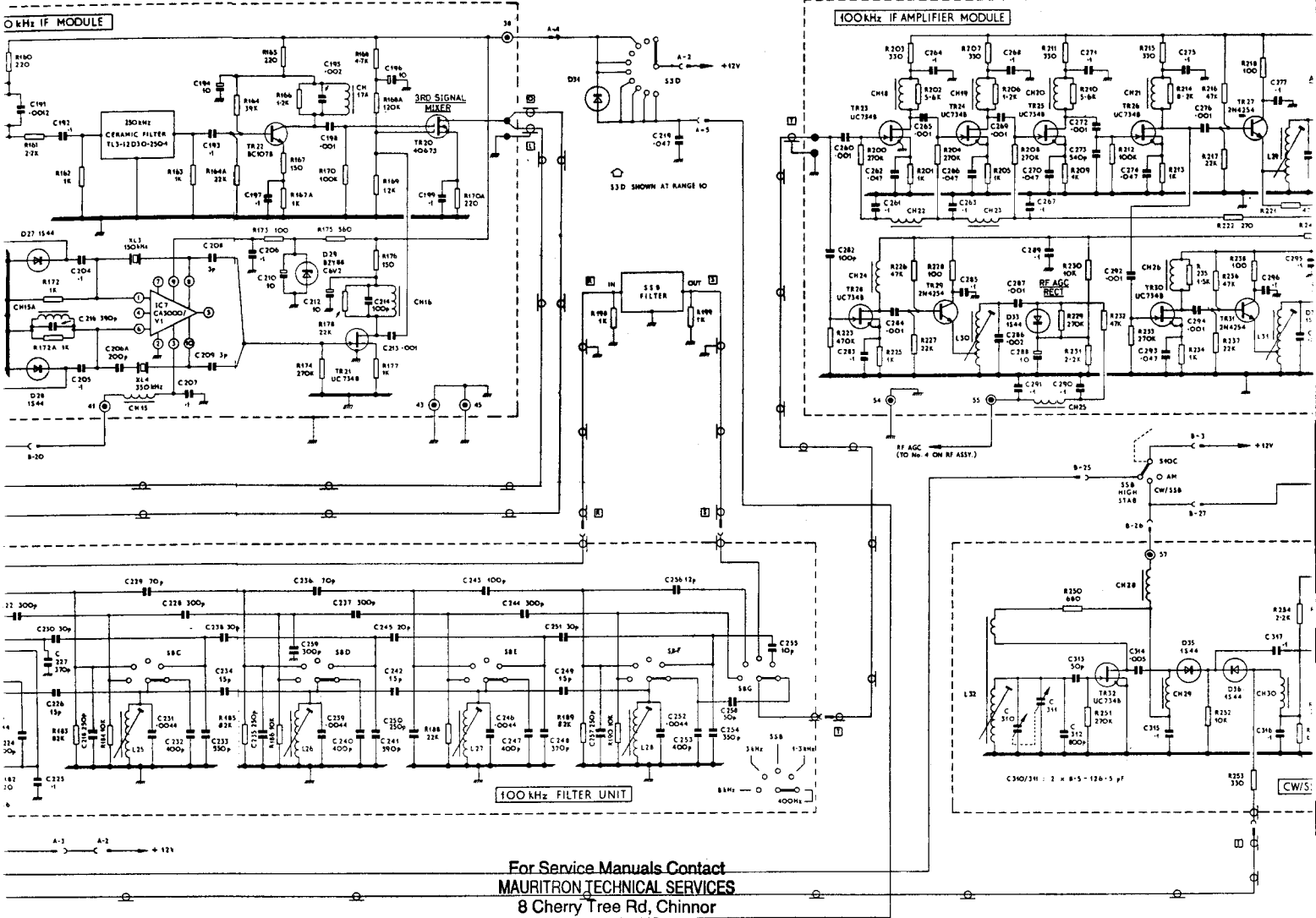

**NOTES**

THIS CIRCUIT DIAGRAM CONFORMS GENERALLY TO THE RECOMMENDATIONS GIVEN IN BS3931. DIAGRAMS OF INTEGRATED CIRCUITS IC1 - IC10 ARE REPRODUCED BY PERMISSION OF THE FOLLOWING MANUFACTURERS: - CA3000 CA3001 CA3012: RCA LIMITED SA21: THORN - AET LTD. SA21A1: MULLARD LTD.

THE FOLLOWING ADDITIONAL DIAGRAMS SHOULD BE USED IN CONJUNCTION WITH THIS CIRCUIT: -

- BP1243 INTERCONNECTION CIRCUIT
- BP1259 TURNEY DISKS A, B & C.
- BP1240 TURNEY DISKS D, E & F.

PL22: MINATURE 15-WAY CONNECTOR COMPLETING WIRING HARNESS TO TURNING DRIVE ASSEMBLY. CONTACTS MATE WITH SA76 AND ARE SHOWN THUS —C— WITH CODING A-1 THROUGH A-15. REFER TO BP1243 FOR ACTUAL CONTACT CONFIGURATION.

PL2B: MINATURE 37-WAY CONNECTOR COMPLETING WIRING HARNESS TO PANEL ASSEMBLY. CONTACTS MATE WITH SA78 AND ARE SHOWN THUS —C— WITH CODING B-1 THROUGH B-37. REFER TO BP1243 FOR ACTUAL CONTACT CONFIGURATION.

PL2C: MINATURE 15-WAY CONNECTOR FEEDING EXTERNAL ANALOGUE CIRCUITS. CONTACTS MATE WITH FREE CONNECTOR SA/C AND ARE SHOWN THUS —C— CONTACT CONFIGURATION AND EXTERNAL CONNECTIONS TO SA/C ARE SHOWN IN INSET ON THIS DIAGRAM.

INTERCONNECTIONS: TERMINATIONS OF NORMAL WIRING (UNSCREENED LEADS) ARE CODED NUMERICALLY 1-150. THE FOLLOWING NUMBERS IN THIS SERIES ARE NOT USED: - 14-17 30 35 36 30 25 39 40 46 47 50 60 70 93 75 80 85 88-89 96 100.

NOTE: CONNECTIONS ARE MADE WITH SINGLE PIN AND SOCKET CONNECTORS WHICH ARE SHOWN THUS —C— SOLDERED TERMINATIONS ARE SHOWN THUS —C— COAXIAL INTERCONNECTING LEADS ARE CODED [ ] TO [ ] INCLUSIVE. ASSOCIATED CONNECTORS ARE IDENTIFIED BY THE LETTER APPROPRIATE TO THE LEAD IN WHICH THEY OCCUR.

PL2D: MINATURE POLARIZED 2-WAY CONNECTOR CARRYING SUPPLY

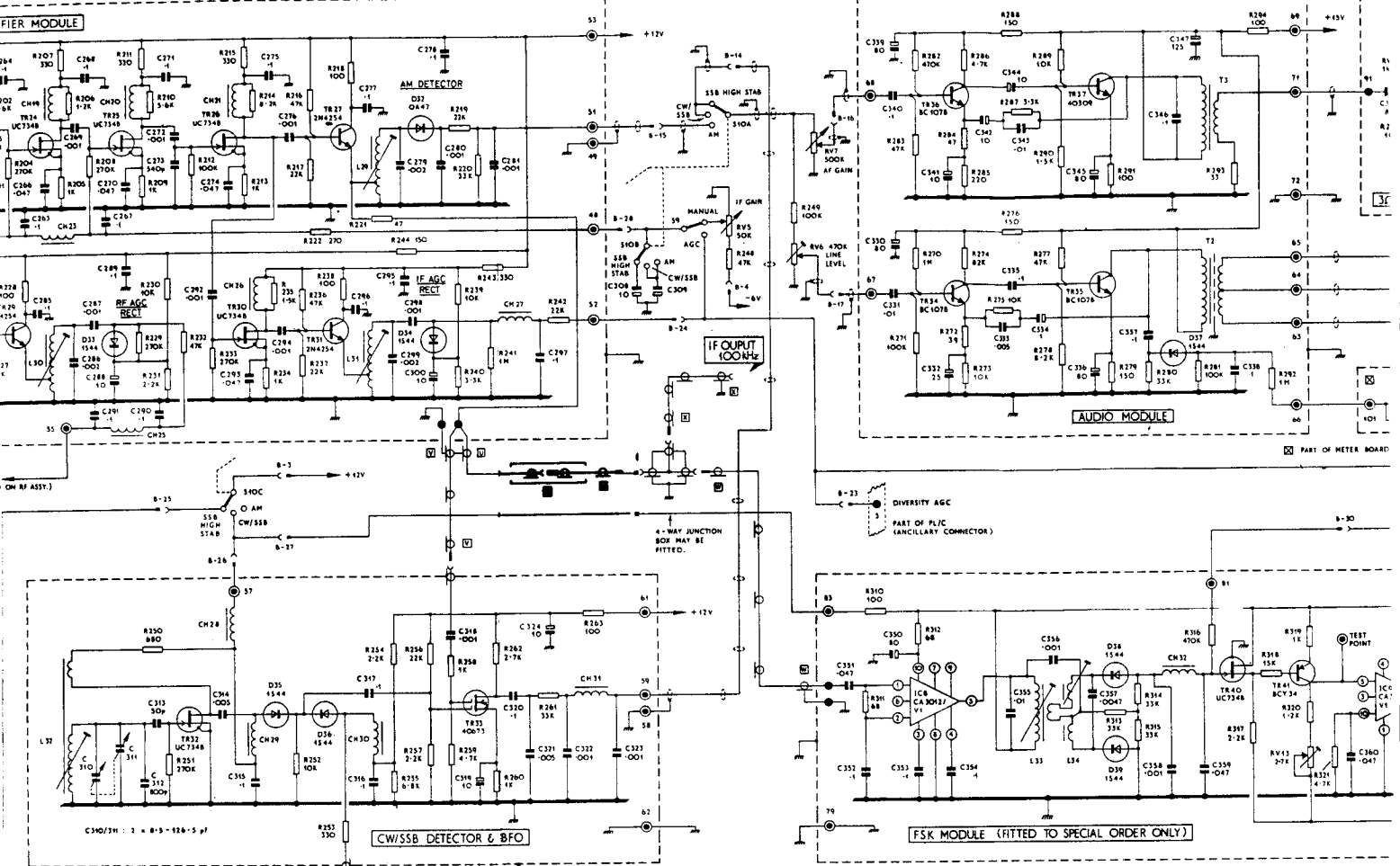

**CIRCUIT CHANGES (VALUES ETC)**

TR 13 = BC 107B	C 155A = 250pF	R 20 = 6.8K
D 31 = 1N 4004	C 157 = 680pF	R 112 = 3.9K
RV 2 = 2.2K	C 309 = 1µF	R 119 = 680Ω
RV 4 = 10K	C 376/C 377 = 0.047µF	

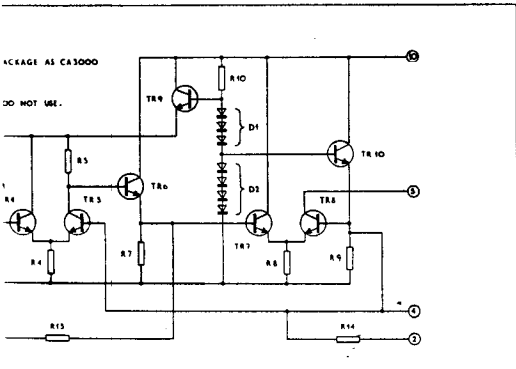

**NOTES**

1. TO THE

2. PRODUCED BY

3. TUBERS :-

4. HULLARD LTD.

5. SHOULD BE USED

6. COMPLETING WIRING

7. MATE WITH

8. CODING B-1

9. ACTUAL

10. MINIATURE 45-WAY CONNECTOR FEEDING EXTERNAL ANCILLARY CIRCUITS. CONTACTS MATE WITH FREE CONNECTOR SE/C AND ARE SHOWN THUS: —

11. CONTACT CONFIGURATION AND EXTERNAL CONNECTIONS TO SE/C ARE SHOWN IN INSET ON THIS DIAGRAM.

12. TERMINATIONS OF NORMAL WIRING (INCLUDING SCREENED LEADS) ARE CODED NUMERICALLY 1-150. THE FOLLOWING NUMBERS IN THIS SERIES ARE NOT USED: 16-17 20 25 28 30 35 39 40 46 47 50 60 70 72 75 80 85 88-90 96 100.

13. MOST CONNECTIONS ARE MADE WITH SINGLE PIN AND SOCKET CONNECTORS WHICH ARE SHOWN THUS: —

14. SOLDERED TERMINATIONS ARE SHOWN THUS: —

15. COAXIAL INTERCONNECTING LEADS ARE CODED □ TO □ INCLUSIVE. ASSOCIATED CONNECTORS ARE IDENTIFIED BY THE LETTER APPROPRIATE TO THE LEAD IN WHICH THEY OCCUR.

16. MINIATURE POLARIZED 2-WAY CONNECTOR CARRYING SUPPLY TO

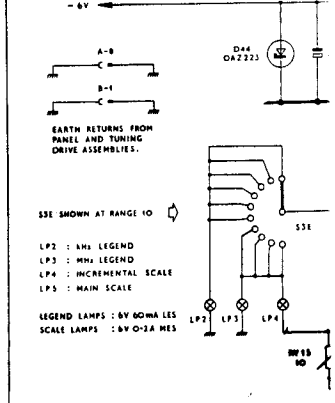
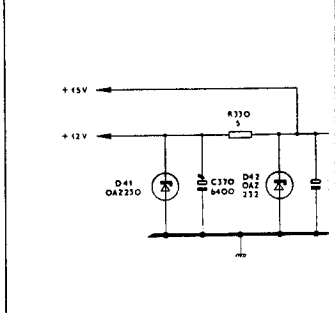
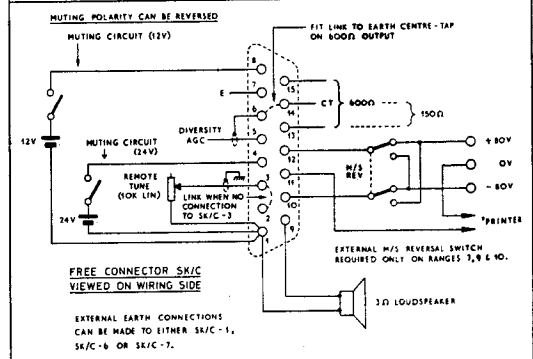
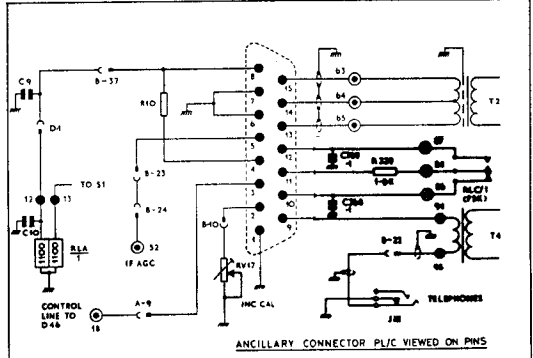

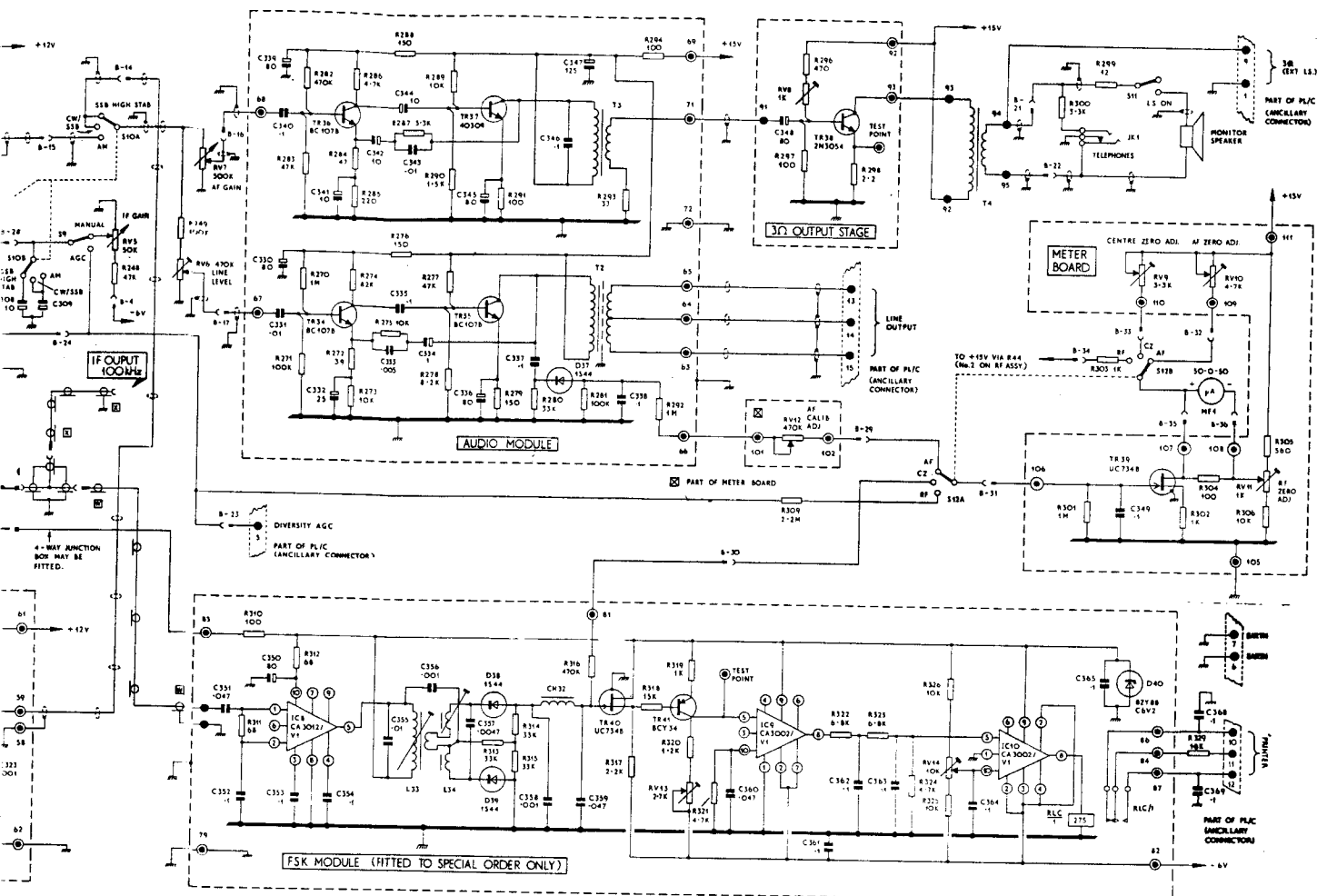

**CHANGES (VALUES ETC)**

C 107B	C 155A = 250pF	R 20 = 6.8K
N 4004	C 157 = 680pF	R 112 = 3.9K
2K	C 309 = 1µF	R 119 = 68Ω
K	C 376/C 377 = 0.047µF	

For Service Manuals Contact  
**MAURITRON TECHNICAL SERVICES**  
 8 Cherry Tree Rd, Chinnor  
 Oxon OX9 4QY  
 Tel: 01844-351694 Fax: 01844-352554  
 Email: enquiries@maurtron.co.uk

